

# STEREO RECEIVER

# R-5000

# SERVICE MANUAL

## FRONT PANEL

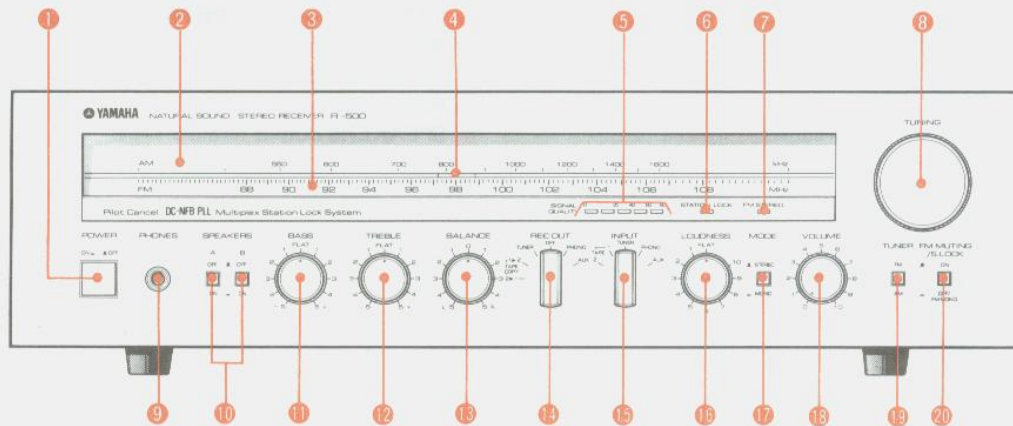

- |                             |                             |
|-----------------------------|-----------------------------|
| 1 POWER switch              | 11 BASS control             |
| 2 AM dial scale             | 12 TREBLE control           |
| 3 FM dial scale             | 13 BALANCE control          |
| 4 Tuning indicator          | 14 REC OUT selector         |
| 5 SIGNAL QUALITY indicators | 15 INPUT selector           |
| 6 STATION LOCK indicator    | 16 LOUDNESS control         |
| 7 FM STEREO indicator       | 17 MODE switch              |
| 8 TUNING knob               | 18 VOLUME control           |
| 9 PHONES jack               | 19 TUNER switch             |
| 10 SPEAKERS switches        | 20 FM MUTING/S. LOCK switch |

## CONTENTS

■ REAR PANEL .....	1
■ INTERNAL COMPONENTS .....	1
■ SPECIFICATIONS .....	2
■ DISASSEMBLY PROCEDURES .....	3/4
■ DIAL MECHANISM .....	4
■ ADJUSTMENTS .....	5/6/7/8
■ BLOCK DIAGRAM .....	9
■ WIRING .....	10
■ SCHEMATIC DIAGRAM .....	11

004420

SINCE 1887



**YAMAHA**

NIPPON GAKKI CO., LTD. HAMAMATSU, JAPAN

# R-500

## REAR PANEL

U.S.A and Canadian Models

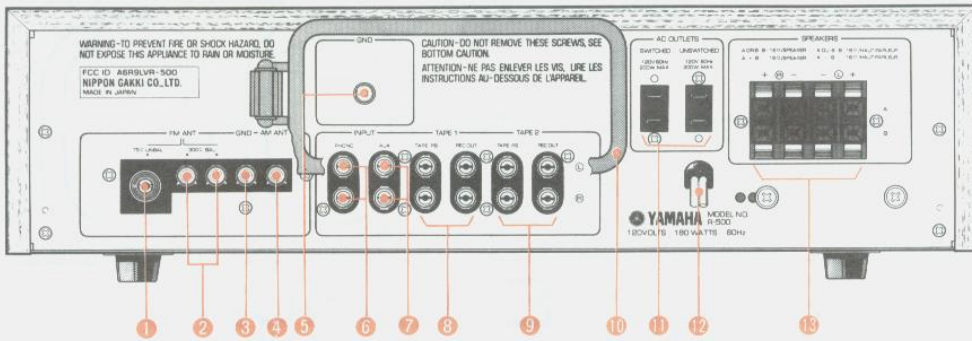

- |   |  |
|---|--|
| <ul style="list-style-type: none"> <li>1 FM ANTENNA terminal (75Ω UNBAL)</li> <li>2 FM ANTENNA terminals (300Ω BAL)</li> <li>3 GND (Earth) terminal</li> <li>4 AM ANTENNA terminal</li> <li>5 GND terminal</li> <li>6 PHONO input terminals</li> <li>7 AUX input terminals</li> </ul> | <ul style="list-style-type: none"> <li>8 TAPE 1 terminals (TAPE PB and REC OUT)</li> <li>9 TAPE 2 terminals (TAPE PB and REC OUT)</li> <li>10 AM loop antenna</li> <li>11 AC OUTLETS</li> <li>12 Power cord</li> <li>13 SPEAKERS output terminals A/B</li> </ul> |
|---|--|

## INTERNAL COMPONENTS

•Top View

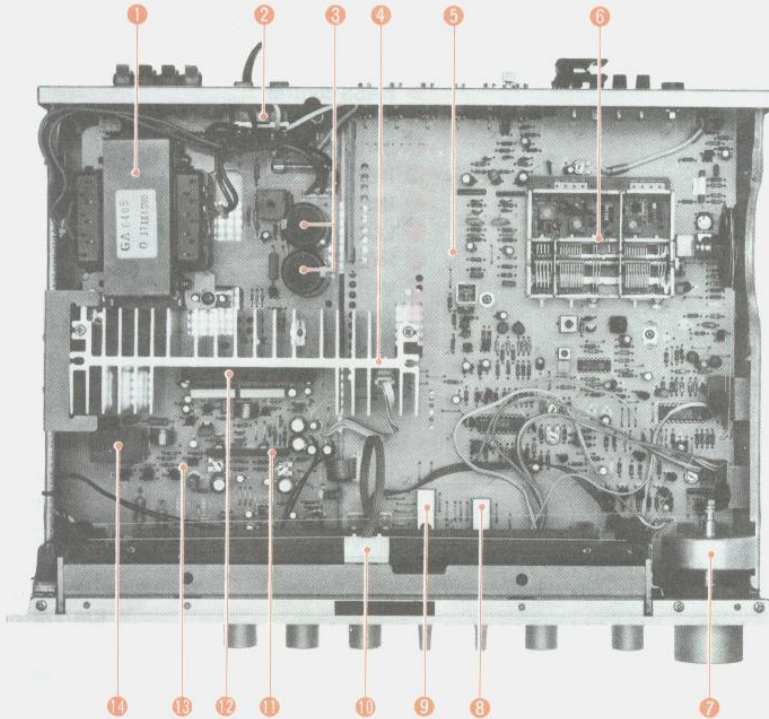

- 1 Power transformer
- 2 AC outlets
- 3 Electrolytic capacitor (C340, 341)
- 4 Heat sink
- 5 Tuner c. board 1
- 6 Front-end pack (PK101)
- 7 Flywheel
- 8 Input selector switch (SW102)
- 9 Rec out selector switch (SW101)
- 10 Dial pointer
- 11 Voltage amplifier IC (IC302)
- 12 Power IC (IC303)
- 13 Main c. board 1
- 14 Relay (RY301)

## SPECIFICATIONS

### AUDIO SECTION

<b>Continuous Output Power Per Channel (IHF)</b>	
20Hz ~ 20kHz (0.015% THD, 8Ω)	40W (16.0 dBW)
1kHz (0.01% THD, 8Ω)	45W (16.5 dBW)
<b>DIN Standard Output Power Per Channel</b>	
1kHz (1% THD, 8Ω)	48W (G)
<b>Power Bandwidth</b>	
0.02% THD, 20W (8Ω)	5Hz ~ 40kHz
<b>Damping Factor (at 1kHz, 8Ω)</b>	
	better than 40
<b>Input Sensitivity/Impedance</b>	
Phono	2.5 mV/47 kΩ, 220pF
	2.5 mV/47 kΩ, 470pF (G)
Aux, Tape	120 mV/47 kΩ
DIN terminal	120 mV/45 kΩ (G)
<b>Input Sensitivity (New IHF)</b>	
Phono	0.4 mV
Aux, Tape	19 mV
<b>Maximum Input Level (0.01% THD)</b>	
Phono 20Hz ~ 20 kHz	150 mV
1 kHz	180 mV
<b>Output Level/Impedance</b>	
Rec Out (Phono)	120 mV/470Ω
DIN Out	28 mV/52 kΩ (G)
<b>Headphone Jack Rated Output/</b>	
<b>Output Impedance</b>	
0.015% THD	0.63 V/220 Ω
<b>Frequency Response</b>	
Aux, Tape	10Hz ~ 100kHz -1dB
<b>Total Harmonic Distortion (20Hz ~ 20kHz)</b>	
Phono (3V)	0.005%
Aux, Tape to Sp Out (1W/8Ω)	0.005%
<b>Intermodulation Distortion</b>	
Aux, Tape Rated output/8Ω	0.01%
1W/8Ω	0.015%
<b>Signal-to-Noise Ratio (IHF-A Network)</b>	
Phono (5mV, Input shorted)	85 dB
	75 dB (G)
Aux, Tape (Input shorted)	100 dB
	100 dB (G)
<b>Signal-to-Noise Ratio (New IHF)</b>	
Phono	74 dB
Aux, Tape	82 dB
<b>Tone Control Characteristics</b>	
Bass boost/cut	± 10 dB (at 50 Hz)
Bass turnover frequency	350 Hz
Treble boost/cut	± 10 dB (at 20 kHz)
Treble turnover frequency	3.5 kHz
<b>Continuous Loudness Control</b> (Level-related equalization)	
Maximum attenuation	-20 dB (at 1 kHz)
<b>Rec Output Level/Impedance (Fixed)</b>	
FM (100% Mod. 1 kHz)	500 mV/4.4 kΩ
AM (30% Mod. 1 kHz)	150 mV/4.4 kΩ

### FM SECTION

<b>Tuning Range</b>	87.6 ~ 108 MHz
<b>50 dB Quieting Sensitivity</b>	
Mono	3.0 μV (14.8 dBf)
Stereo	20 μV (31.2 dBf)
<b>Usable Sensitivity (IHF Mono, 1 kHz 100% Mod.)</b>	
300 Ω	1.8 μV (10.3 dBf)
75 Ω	0.9 μV (10.3 dBf)

### Usable Sensitivity (DIN, 40 kHz Dev.)

Mono (S/N 26 dB)	1.2 μV (G)
Stereo (S/N 46 dB)	28 μV (G)
<b>Image Response Ratio</b>	50 dB
<b>IF Response Ratio</b>	90 dB
<b>Spurious Response Ratio</b>	70 dB
<b>AM Suppression Ratio (IHF)</b>	60 dB
<b>Capture Ratio</b>	1.5 dB
<b>Alternate Channel Selectivity</b>	55 dB
<b>Signal-to-Noise Ratio (IHF)</b>	
Mono	84 dB
Stereo	80 dB
<b>Harmonic Distortion</b>	
Mono 100 Hz	0.1%
1 kHz	0.1%
6 kHz	0.15%
Stereo 100 Hz	0.15%
1 kHz	0.15%
6 kHz	0.2%
<b>IM-Distortion (IHF)</b>	
Mono	0.1%
Stereo	0.15%
<b>Stereo Separation</b>	
50 Hz	30 dB
1 kHz	40 dB
10 kHz	30 dB
<b>Frequency Response</b>	
50 Hz ~ 10 kHz	± 0.3 dB
30 Hz ~ 15 kHz	+0.5 -1.5 dB
<b>Sub-carrier Product Ratio</b>	45 dB
<b>Muting Threshold</b>	3μ V (14.8 dBf)
<b>Blend Switching Threshold</b>	30μV (34.8 dBf)

### AM SECTION

<b>Tuning Range</b>	525 ~ 1605 kHz
<b>Usable Sensitivity (IHF, Loop Ant.)</b>	300 μV/m
<b>Selectivity (± 10 kHz)</b>	30 dB
<b>Signal-to-Noise Ratio</b>	50 dB
<b>Image Response Ratio</b>	40 dB
<b>Spurious Response Ratio</b>	50 dB
<b>Harmonic Distortion (1 kHz)</b>	0.4%

### GENERAL

<b>Semiconductor</b>	28 Transistors
	12 ICs, 1 FET
	10 LEDs, 19 Diodes

### Power Supplies

USA and Canadian models	AC120V, 60 Hz
North European model	AC220V, 50Hz
British and Australian models	AC240V, 50Hz
General model	AC110/120/220/240V 50/60 Hz

### Power Consumption

USA and Canadian models	180W
North European, British and Australian models	250W
General model	100W
<b>Dimensions (W x H x D)</b>	435 x 122 x 337 mm (17-1/8 x 4-3/4 x 13-1/4 in)
<b>Weight</b>	8 kg (17.6 lbs)

\* (G) ..... North European model only  
Specifications subject to change without notice.

■ DISASSEMBLY PROCEDURES

1. Top Cover Removal

Loosen screws ① and ② as shown in Photo 1 for both left and right sides. Slide the top cover back a little and lift off.



Photo 1

2. Bottom Cover Removal

Turn the set upside down, and loosen screws ① to ⑧ shown in Photo 2 to remove the bottom cover.

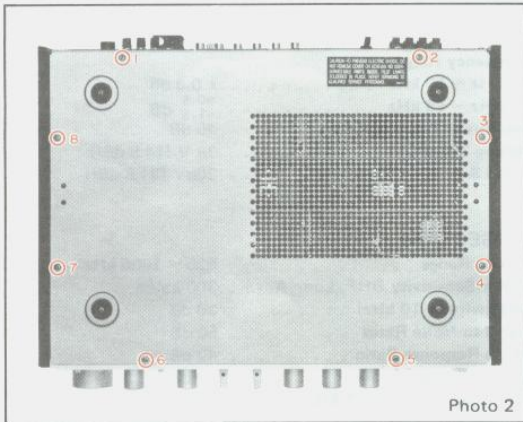

Photo 2

3. Front Panel Removal

- 1) Remove the top and bottom covers (as described in procedures 1 and 2 above).
- 2) Using a 1.5φ allen wrench loosen the set screws securing the REC OUT and INPUT selector knobs. These knobs may then be removed from the set.
- 3) Loosen screws ① to ③ shown in Photo 3, and pull the front panel out forwards.
- 4) Then after removing the plastic rivets ① and ② shown in Photo 4, separate the front panel completely from the set.

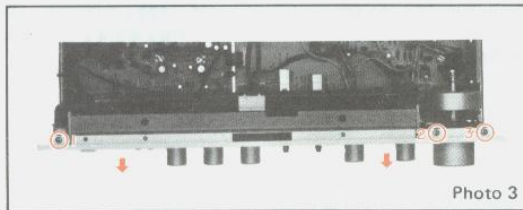

Photo 3

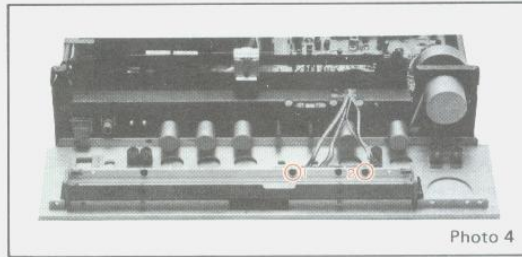

Photo 4

4. Rear Panel Removal

- 1) Remove the top and bottom covers (as described in procedures 1 and 2 above).
- 2) Disconnect the power cord from the set at the AC OUTLETS position.
- 3) Loosen screws ① to ⑱ shown in Photo 5 and screw ⑳ shown in Photo 6 to enable the removal of the rear panel.

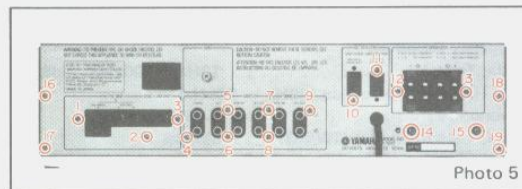

Photo 5

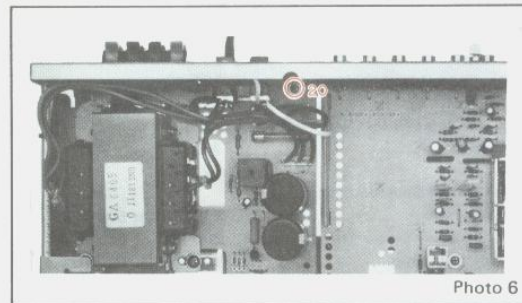
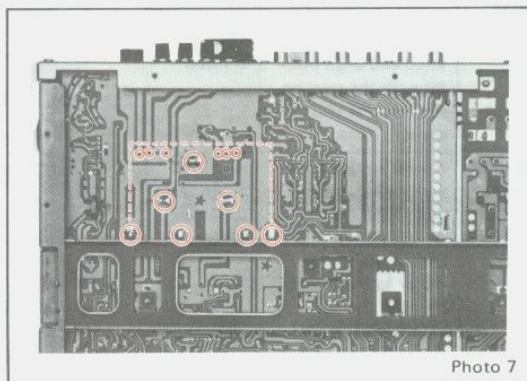
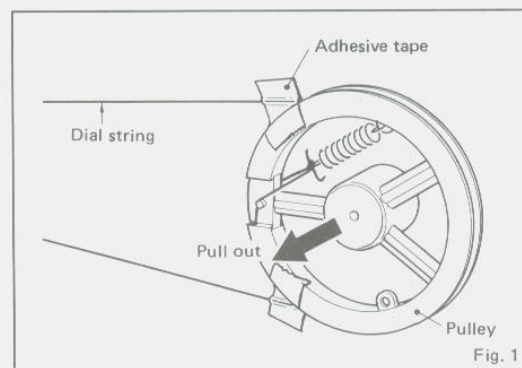

Photo 6

### 5. Front-end Pack Removal

- 1) Remove the top and bottom covers (as described in procedures 1 and 2 above).
- 2) Move the dial pointer to the left hand end of the tuning dial scale. (This status will serve as a reference position when remounting the pulley).
- 3) Secure the dial string to the pulley with adhesive tape etc., as shown in Fig. 1, and pull out the pulley from the shaft.
- 4) Then after removing the solder from the positions marked ○ in Photo 7, remove the front-end pack.



### ■ DIAL MECHANISM

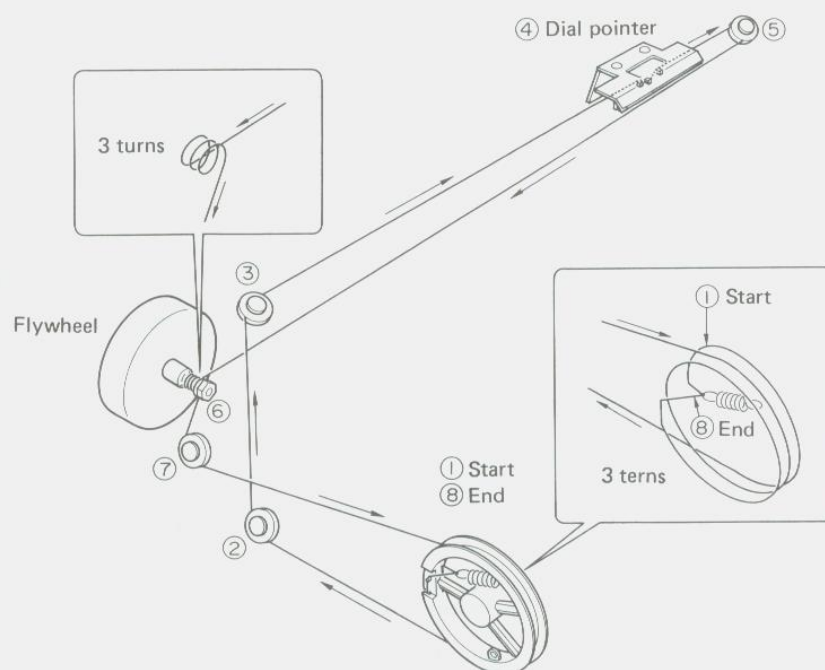

## ■ ADJUSTMENTS

- Adjustment is to be carried out only after 5 minutes.

### 1. FM tuner overall adjustment

1. Set the switches to the following positions.

TUNER switch ..... FM

FM MUTING/S. LOCK switch ..... ON

2. Perform this adjustment and a lowpass filter must be used.

3. Abbreviation of instruments

FM SG : FM signal generator

OSC : Oscilloscope

D.M : Digital multimeter

DIST.M : Distortion meter

F.C. : Frequency counter

Step	Adjustment items	Terminals to be connected	Instrument required	Adjustment location	Adjustment method	Rating	Remarks
1	Pointer alignment			Tuning knob pointer	Rotate the tuning knob and align pointer with the starting point of the dial scale.	Within $\pm 1$ mm	
2	Tracking adjustment I	FM antenna terminal 300 $\Omega$ BAL	FM SG 104MHz	*Tuning knob *Local oscillator trimmer	Rotate tuning knob and align pointer with 104MHz on dial scale. Adjust the tuning meter to the center position by means of the local oscillator trimmer.	Within $\pm 1$ mm from the letter center.	
3	Tracking adjustment II	- do. -	- do. -	Local oscillator trimmer (Dial pointer LED)	Adjust deviation as specified all over the frequency range.	Less than $\pm 2$ mm (92 ~ 104 MHz)	Adjust only when pointer deviates with step 2.
4	Discriminator balance	- do. -	- do. -	T101 Discriminator coil	Adjust the tuning meter to give a center reading due to between station noise in the 98MHz region.		Set at detuned point.
5	Setting tuned point	- do. -	FM SG 98MHz, ANT input 60 dB $\mu$	Tuning knob	Set tuning meter to indicate the center.		
6	Monaural distortion adjustment	- do. - REC OUT L alone	- do. - MONO 1KHz 100% modulation OSC DIST.M	VC101	Reduce distortion to minimum.	Less than -56dB (-60dB)	
7	VCO adjustment	19KHz T.P - Ground	Nonmodulated F.C.	VCO ADJ. VR101 (10K $\Omega$ B)	Set to 19KHz.	19KHz $\pm$ 20Hz ( $\pm$ 10Hz)	At detuned point.
8	Stereo distortion adjustment	FM antenna terminal REC OUT L alone	Same as Step 5. Stereo 1KHz 100% modulation OSC, D.M, DIST.M	VR104 (2K $\Omega$ B)	Reduce distortion to minimum.	Less than -50dB (-54dB)	
9	Pilot cancel adjustment	FM antenna terminal REC OUT L, R	Same as Step 5. Pilot 9% modulation. OSC, D.M	VR102 (100K $\Omega$ B)	Adjust the level to a minimum reading in an OSC and D.M.	More than 40dB (45dB)	
10	Signal quality LED adjustment	Same as Step 8.	Same as Step 8.	VR103 (100K $\Omega$ B) Signal quality LED	Adjust so that No.5 LED goes on.		At detuned point, O must be indicated.

# BLOCK DIAGRAM

Rating  
± 10 mV

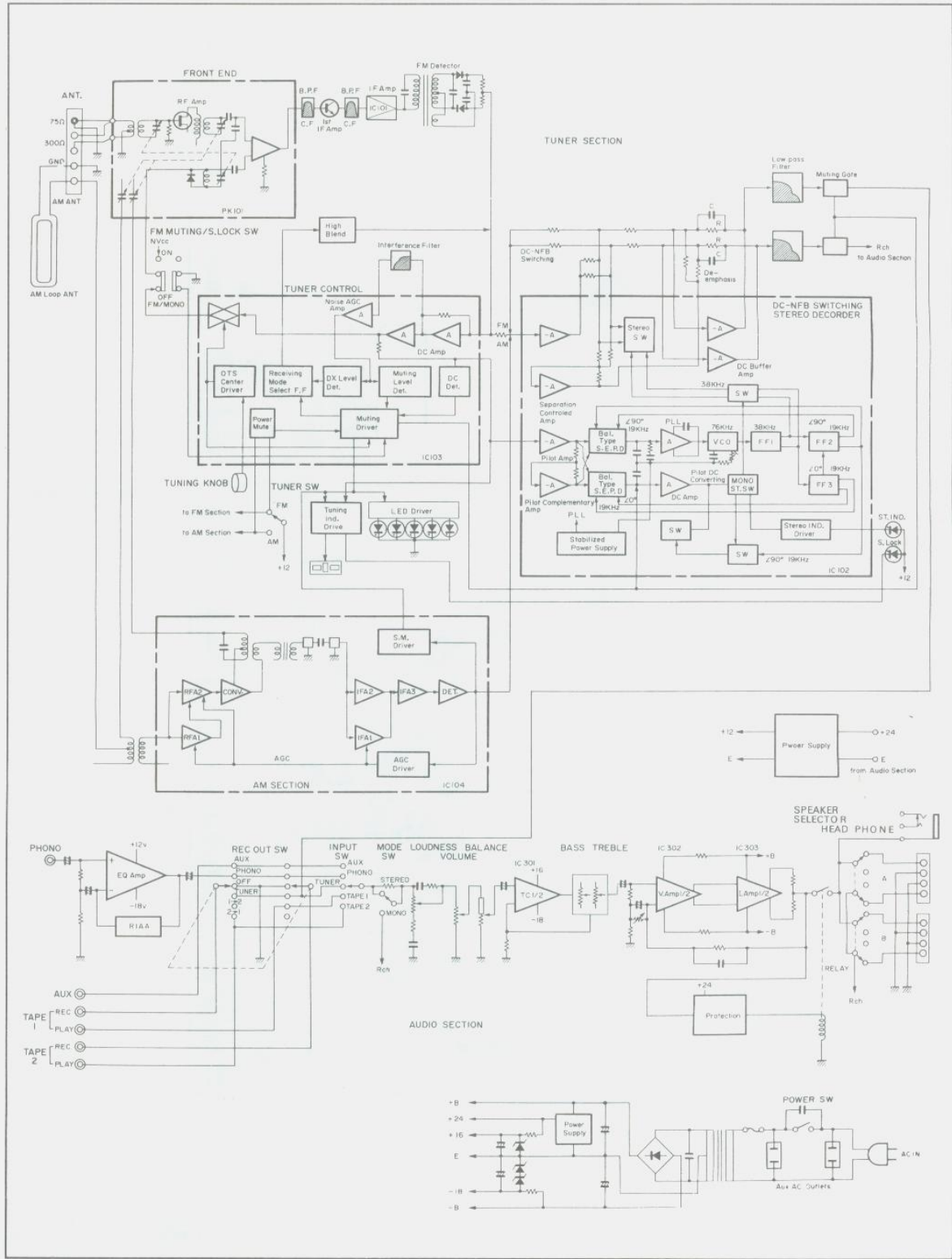

■ Adjusting points

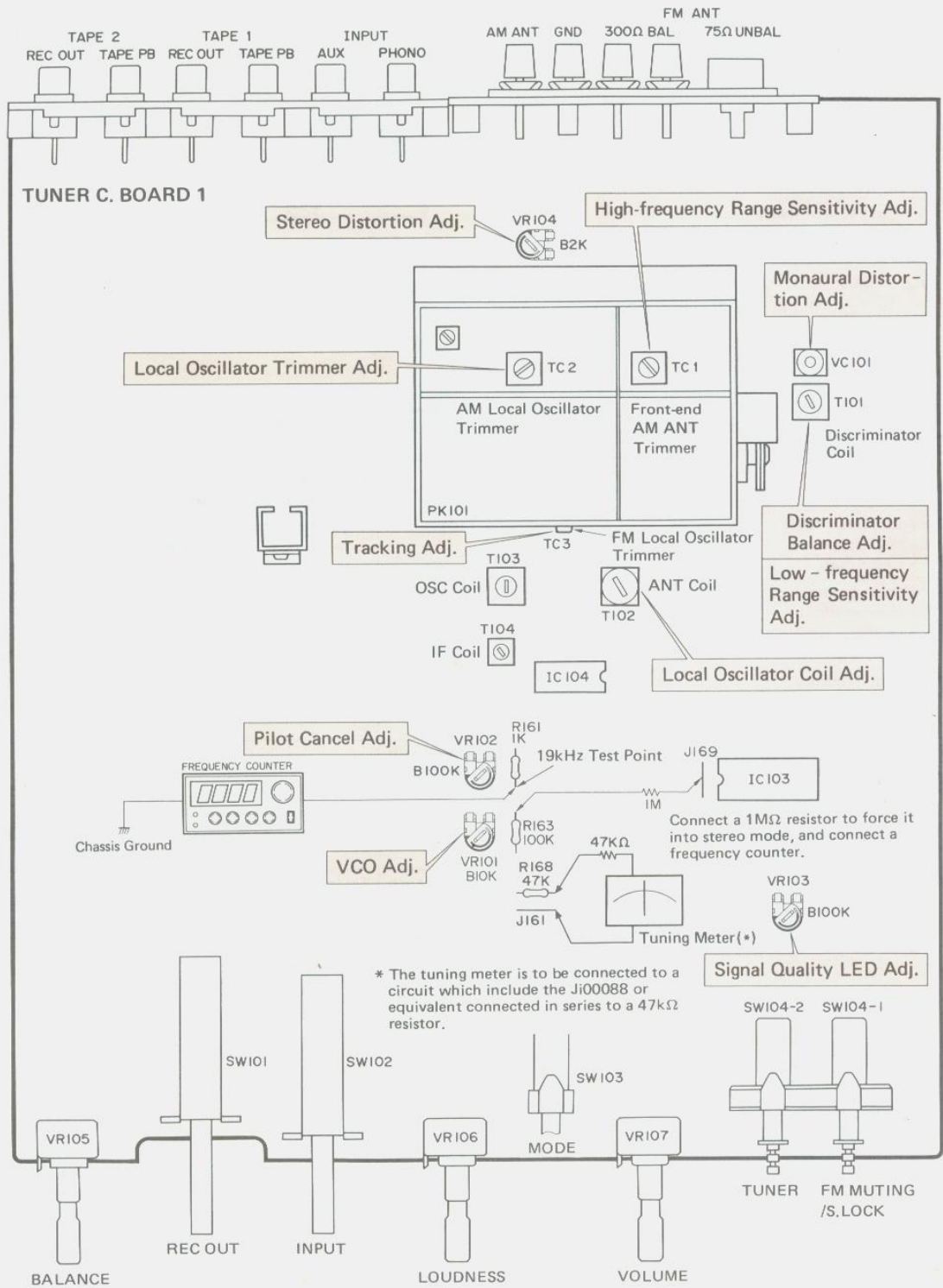

**2. AM tuner adjustment**

1. Set the switch to the following position.  
TUNER switch ..... AM
2. Proceed with the AM section adjustments after having finished the FM section adjustment.
3. The quasi-antenna circuit for AM section adjustment.

Note 1. Quasi-antenna circuit for AM section adjustment.  
Set to be measured.  
Output level shows 50Ω load terminal.

Note 2. Adjustment is made with loop antenna installed and the loop antenna is not to be close to any metal parts.

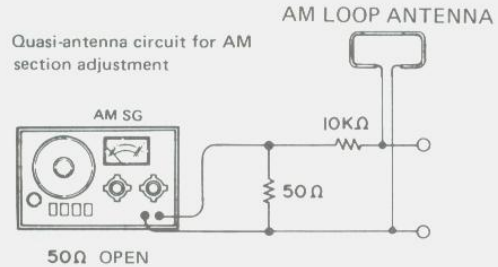

Output level shows the 50Ω load terminal.  
The loop antenna is not to be close to the metal parts.

Step	Adjustment items	Terminals to be connected	Instrument required	Adjustment location	Adjustment method	Rating
1	Local oscillator coil adjustment	REC OUT L or R	AM SG 600KHz, 60dBμ	Tuning knob, T102	Align pointer with 600KHz using tuning knob, rotate coil core and adjust for a maximum output.	
2	Low-frequency range sensitivity adjustment	- do. -	- do. -	T101	Adjust for a maximum output at same tuning point under step 1.	
3	Local oscillator trimmer adjustment	- do. -	AM SG 1350KHz, 60dBμ	Tuning knob, Front-end Local oscillator Trimmer	Align pointer with 1350KHz using tuning knob, rotate trimmer and set for a maximum output.	
4	High-frequency range sensitivity adjustment	- do. -	- do. -	Front-end AM ANT. Trimmer	Set to for a maximum output at same tuning point under step 3.	
5	Sensitivity difference adjustment	- do. -	AM SG 600KHz 1350KHz 60dBμ	Repeat steps 1 to 4.		Scale deviation: Less than ±1.5mm for 600KHz and 1350KHz
6	Medium frequency range check	- do. -	AM SG 950KHz	Tuning knob	Set for a maximum point.	Scale deviation must be within ±2mm.

## 3. Audio section adjustment

Adjustment item	Terminals to be connected	Instrument required	Adjustment location	Adjustment method	Rating
DC offset voltage adjustment	L301—Earth (Lch) L302—Earth (Rch)	D.M	Main c. board 1 VR303 (Lch) VR304 (Rch)	Adjust deviation as specified.	$0 \pm 10$ mV

## ▪ Adjusting points

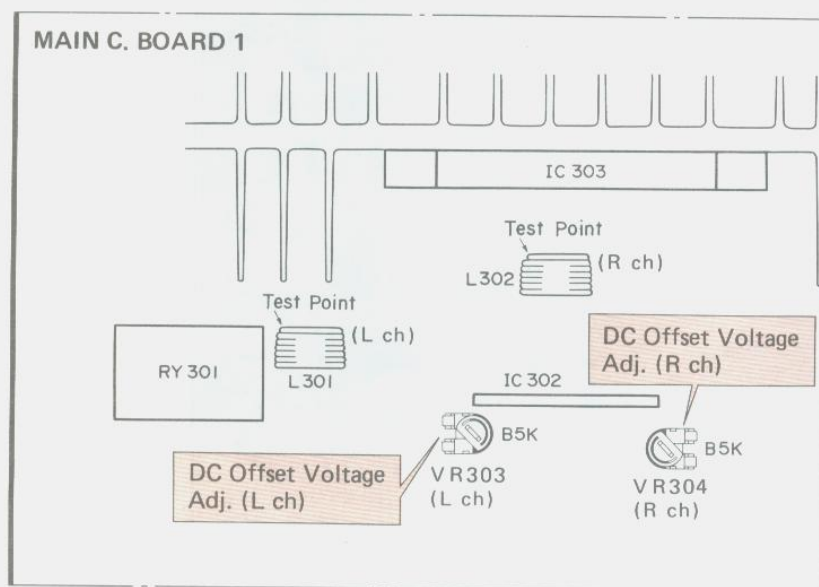

BLOCK DIAGRAM

Rating  
± 10 mV

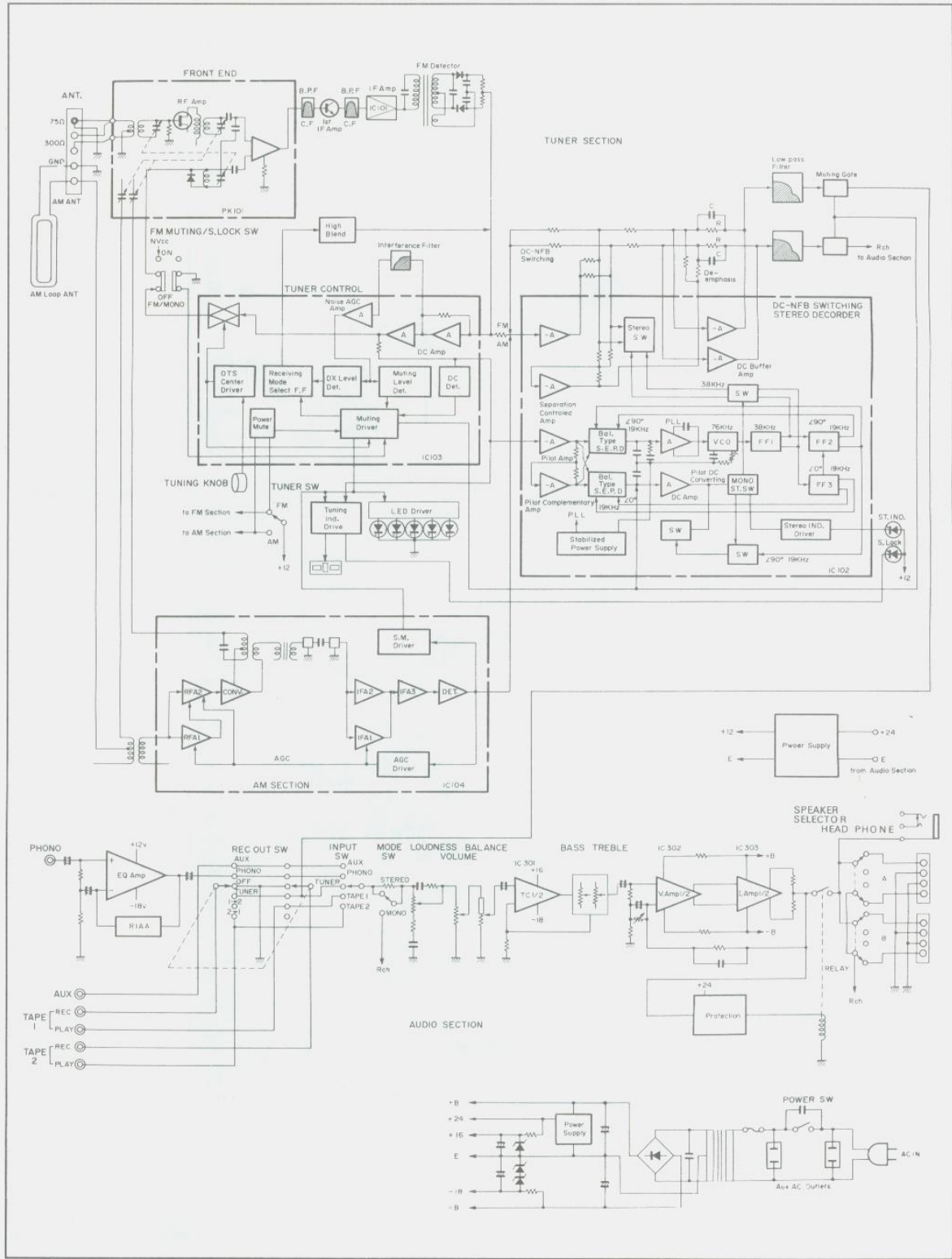

WIRING

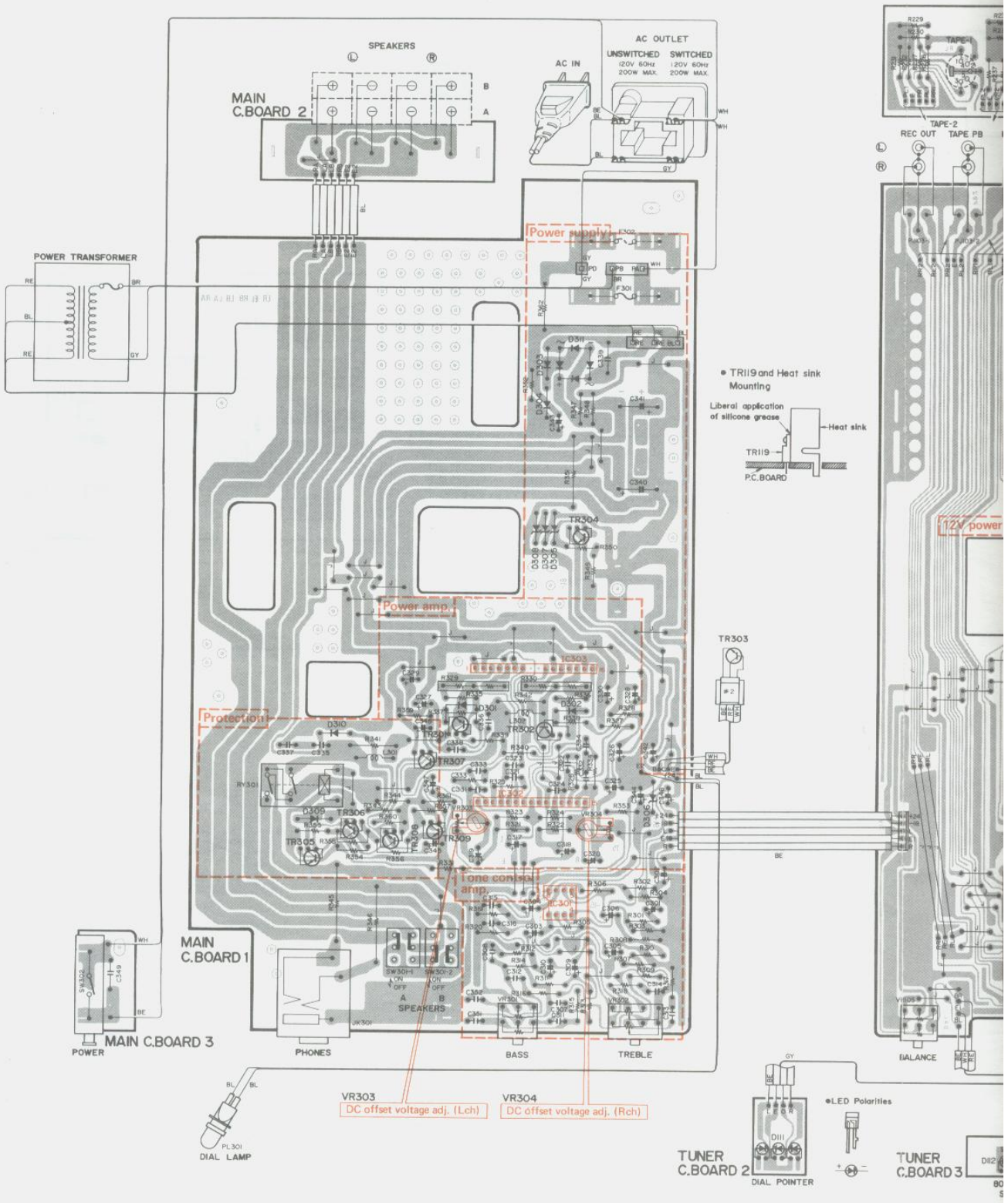

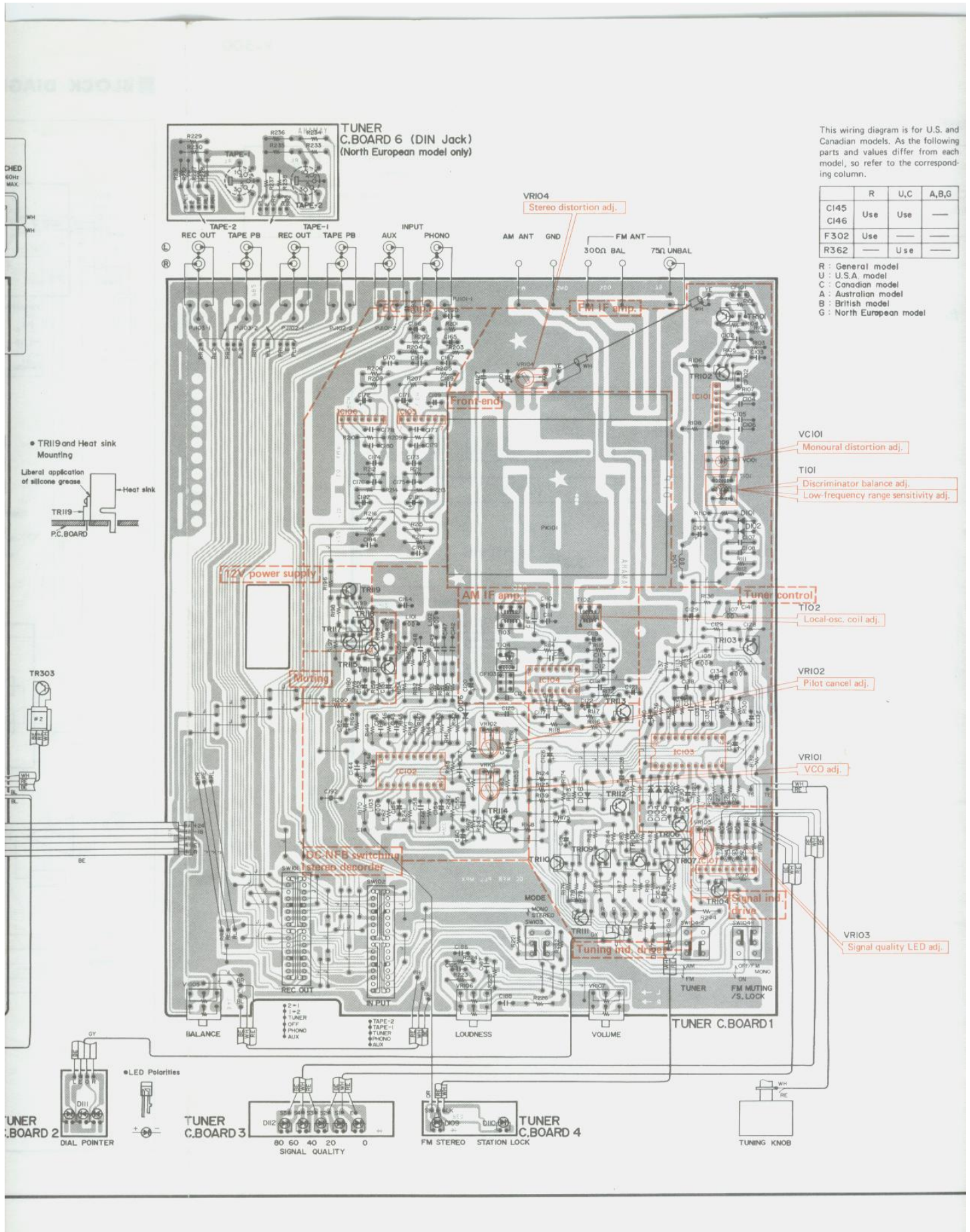

This wiring diagram is for U.S. and Canadian models. As the following parts and values differ from each model, so refer to the corresponding column.

	R	U,C	A,B,G
C145	Use	Use	—
C146	Use	Use	—
F302	Use	—	—
R362	—	Use	—

R : General model  
 U : U.S.A. model  
 C : Canadian model  
 A : Australian model  
 B : British model  
 G : North European model

• TR119 and Heat sink Mounting  
 Liberal application of silicone grease → Heat sink  
 TR119  
 P.C. BOARD

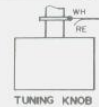
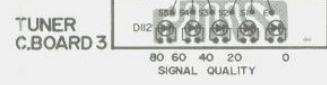
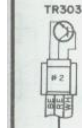

# SCHEMATIC DIAGRAM

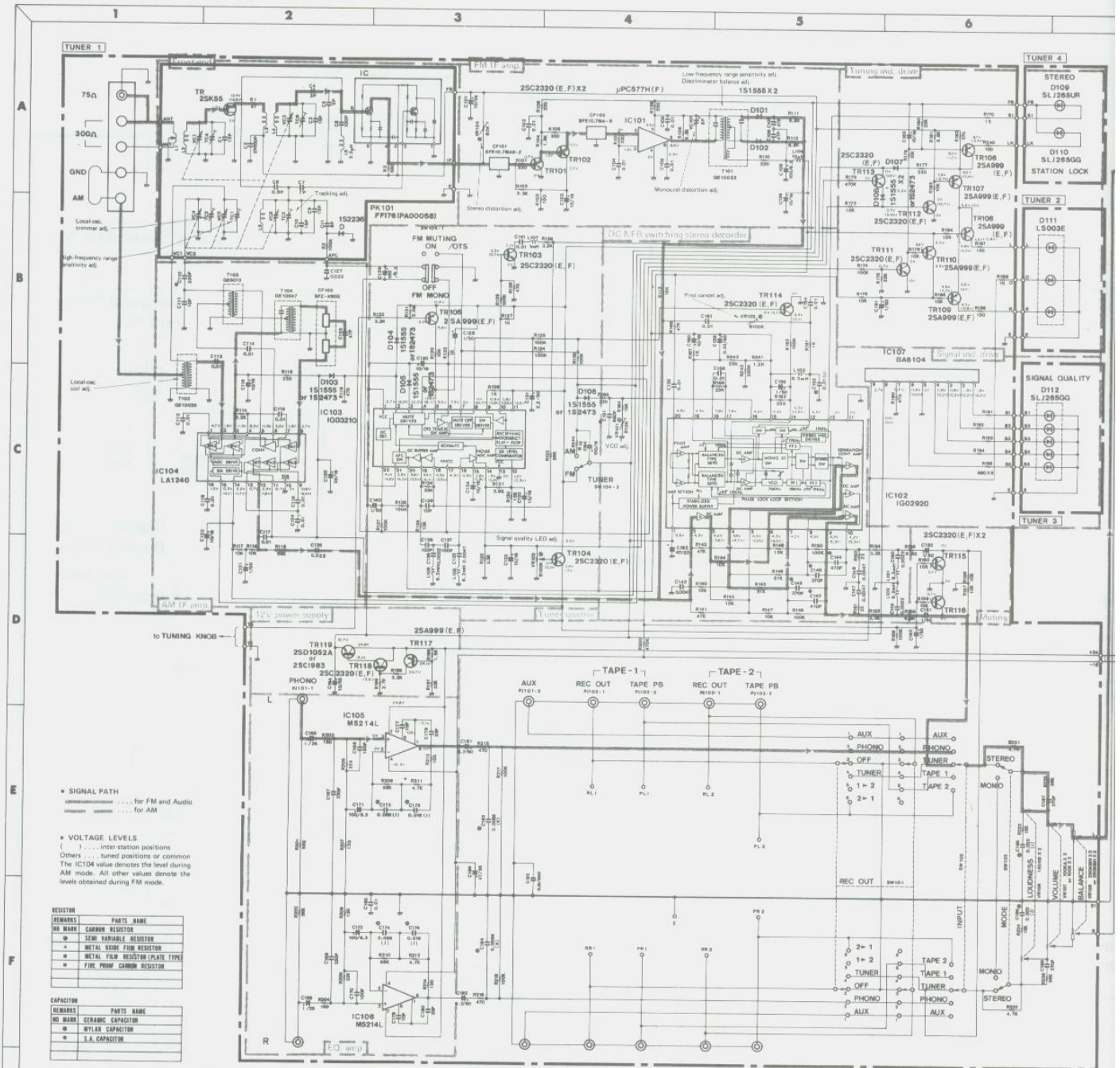

• SIGNAL PATH  
 ..... for FM and Audio  
 ..... for AM

• VOLTAGE LEVELS  
 ( ) ..... inter station positions  
 Others ..... tuned positions or common  
 The IC104 value denotes the level during AM mode. All other values denote the level obtained during FM mode.

RESISTOR	REMARKS	PARTS NAME
Ω	COMMON RESISTOR	
⊗	SEMI-VARIABLE RESISTOR	
⊠	METAL BRIDGE FOLM RESISTOR	
⊡	METAL FILM RESISTOR (PLATE TYPE)	
⊞	FINE POWER CARBON RESISTOR	

CAPACITOR	REMARKS	PARTS NAME
⊚	CERAMIC CAPACITOR	
⊙	MYLAR CAPACITOR	
⊛	3.3 CAPACITOR	

This schematic diagram is for U.S. and Canadian models. As the following parts and values differ from each destination, so refer to the corresponding column.

	R	U.S.C.	A	B	C	D	E
CF10	2500	2500	2500	2500	2500	2500	2500
CF10A	2500	2500	2500	2500	2500	2500	2500
CF10B	2500	2500	2500	2500	2500	2500	2500
CF10C	2500	2500	2500	2500	2500	2500	2500
CF10D	2500	2500	2500	2500	2500	2500	2500
CF10E	2500	2500	2500	2500	2500	2500	2500
CF10F	2500	2500	2500	2500	2500	2500	2500
CF10G	2500	2500	2500	2500	2500	2500	2500
CF10H	2500	2500	2500	2500	2500	2500	2500
CF10I	2500	2500	2500	2500	2500	2500	2500
CF10J	2500	2500	2500	2500	2500	2500	2500
CF10K	2500	2500	2500	2500	2500	2500	2500
CF10L	2500	2500	2500	2500	2500	2500	2500
CF10M	2500	2500	2500	2500	2500	2500	2500
CF10N	2500	2500	2500	2500	2500	2500	2500
CF10O	2500	2500	2500	2500	2500	2500	2500
CF10P	2500	2500	2500	2500	2500	2500	2500
CF10Q	2500	2500	2500	2500	2500	2500	2500
CF10R	2500	2500	2500	2500	2500	2500	2500
CF10S	2500	2500	2500	2500	2500	2500	2500
CF10T	2500	2500	2500	2500	2500	2500	2500
CF10U	2500	2500	2500	2500	2500	2500	2500
CF10V	2500	2500	2500	2500	2500	2500	2500
CF10W	2500	2500	2500	2500	2500	2500	2500
CF10X	2500	2500	2500	2500	2500	2500	2500
CF10Y	2500	2500	2500	2500	2500	2500	2500
CF10Z	2500	2500	2500	2500	2500	2500	2500

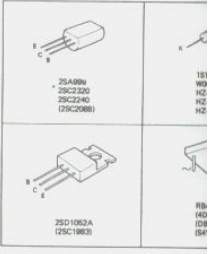
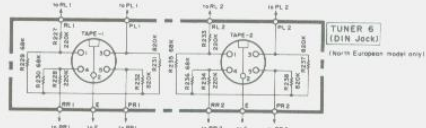

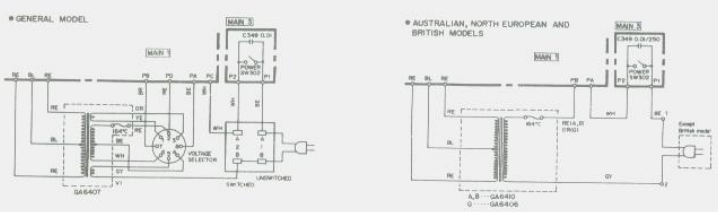
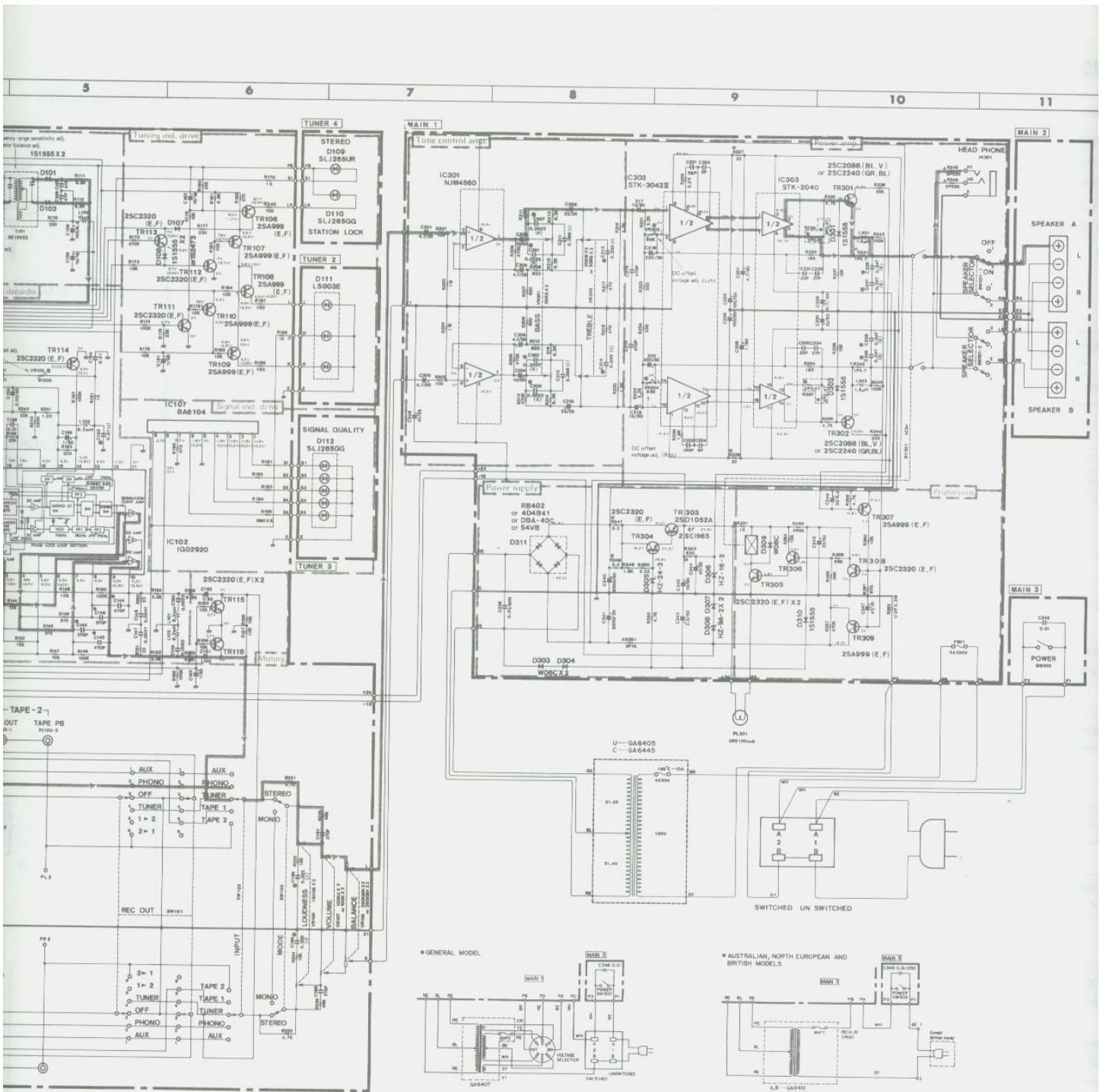

1S1555 X2	1S1555 X2	SL285UR	PC877H	H03210	M5214L	NIM4560	STK-3042E
2SD1062A (2SC1963)	RB402 (4D4841) (D8A-40C) (54V8)	H020920	LA1240	BA8104	STK-2040		

## ■ ADJUSTMENTS

- Adjustment is to be carried out only after 5 minutes.

### 1. FM tuner overall adjustment

- Set the switches to the following positions.  
TUNER switch ..... FM  
FM MUTING/S. LOCK switch ..... ON
- Perform this adjustment and a lowpass filter must be used.

### 3. Abbreviation of instruments

- FM SG : FM signal generator  
OSC : Oscilloscope  
D.M : Digital multimeter  
DIST.M : Distortion meter  
F.C. : Frequency counter

Step	Adjustment items	Terminals to be connected	Instrument required	Adjustment location	Adjustment method	Rating	Remarks
1	Pointer alignment			Tuning knob pointer	Rotate the tuning knob and align pointer with the starting point of the dial scale.	Within $\pm 1$ mm	
2	Tracking adjustment I	FM antenna terminal 300 $\Omega$ BAL	FM SG 104MHz	*Tuning knob *Local oscillator trimmer	Rotate tuning knob and align pointer with 104MHz on dial scale. Adjust the tuning meter to the center position by means of the local oscillator trimmer.	Within $\pm 1$ mm from the letter center.	
3	Tracking adjustment II	— do. —	— do. —	Local oscillator trimmer (Dial pointer LED)	Adjust deviation as specified all over the frequency range.	Less than $\pm 2$ mm (92 ~ 104 MHz)	Adjust only when pointer deviates with step 2.
4	Discriminator balance	— do. —	— do. —	T101 Discriminator coil	Adjust the tuning meter to give a center reading due to between station noise in the 98MHz region.		Set at detuned point.
5	Setting tuned point	— do. —	FM SG 98MHz, ANT input 60 dB $\mu$	Tuning knob	Set tuning meter to indicate the center.		
6	Monaural distortion adjustment	— do. — REC OUT L alone	— do. — MONO 1KHz 100% modulation OSC DIST.M	VC101	Reduce distortion to minimum.	Less than -56dB (-60dB)	
7	VCO adjustment	19KHz T.P - Ground	Nonmodulated F.C.	VCO ADJ. VR101 (10K $\Omega$ B)	Set to 19KHz.	19KHz $\pm$ 20Hz ( $\pm$ 10Hz)	At detuned point.
8	Stereo distortion adjustment	FM antenna terminal REC OUT L alone	Same as Step 5. Stereo 1KHz 100% modulation OSC, D.M. DIST.M	VR104 (2K $\Omega$ B)	Reduce distortion to minimum.	Less than -50dB (-54dB)	
9	Pilot cancel adjustment	FM antenna terminal REC OUT L, R	Same as Step 5. Pilot 9% modulation. OSC, D.M	VR102 (100K $\Omega$ B)	Adjust the level to a minimum reading in an OSC and D.M.	More than 40dB (45dB)	
10	Signal quality LED adjustment	Same as Step 8.	Same as Step 8.	VR103 (100K $\Omega$ B) Signal quality LED	Adjust so that No.5 LED goes on.		At detuned point, O must be indicated.

▪ Adjusting points

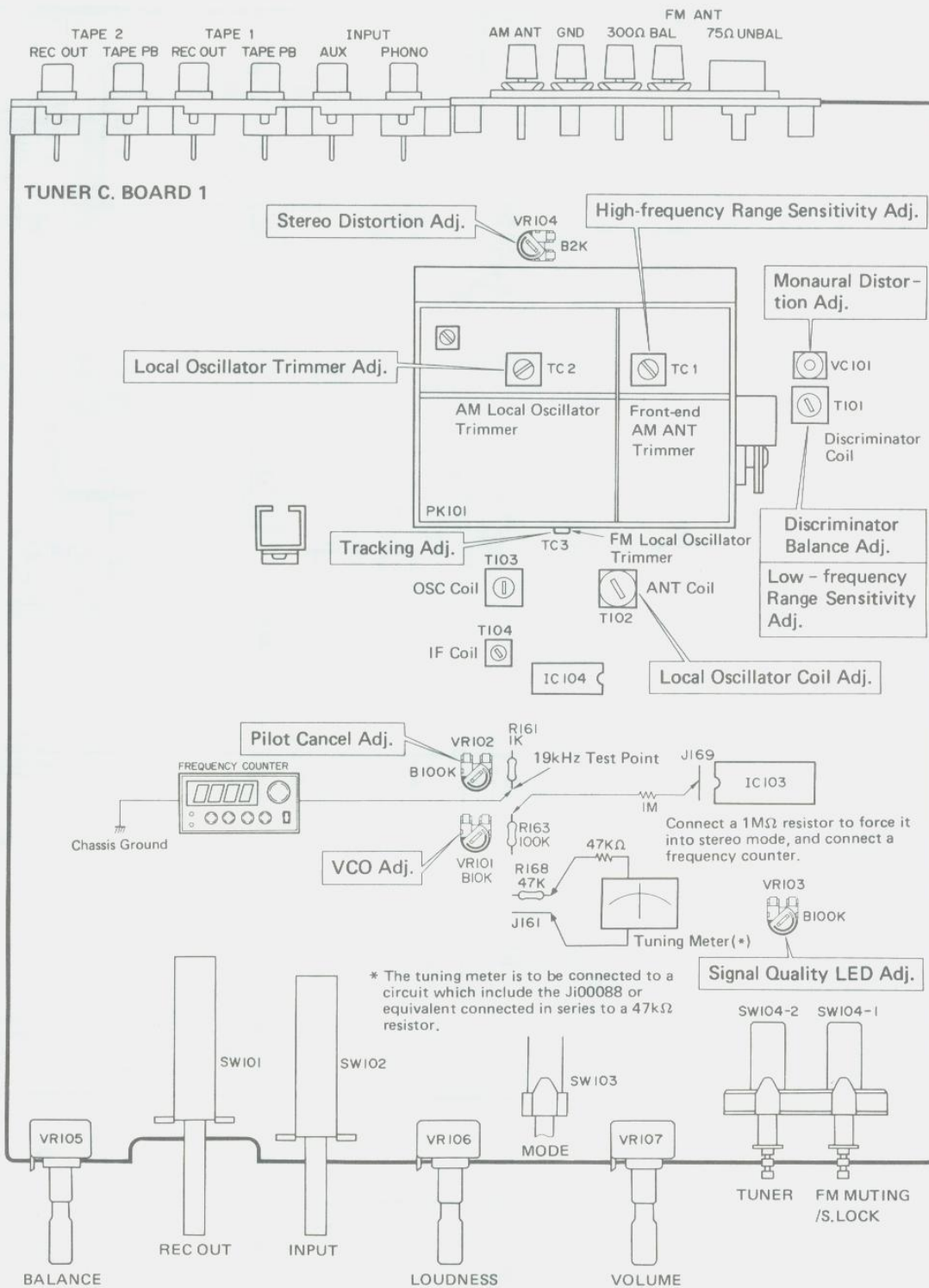

## 2. AM tuner adjustment

1. Set the switch to the following position.  
TUNER switch ..... AM
2. Proceed with the AM section adjustments after having finished the FM section adjustment.
3. The quasi-antenna circuit for AM section adjustment.

Note 1. Quasi-antenna circuit for AM section adjustment.

Set to be measured.

Output level shows 50Ω load terminal.

Note 2. Adjustment is made with loop antenna installed and the loop antenna is not to be close to any metal parts.

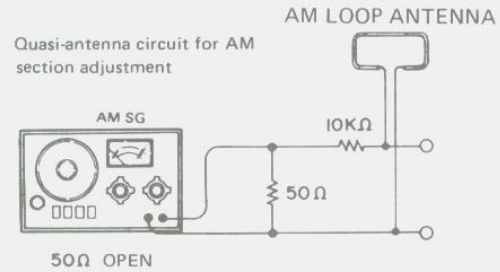

Output level shows the 50Ω load terminal.

The loop antenna is not to be close to the metal parts.

Step	Adjustment items	Terminals to be connected	Instrument required	Adjustment location	Adjustment method	Rating
1	Local oscillator coil adjustment	REC OUT L or R	AM SG 600KHz, 60dBμ	Tuning knob, T102	Align pointer with 600KHz using tuning knob, rotate coil core and adjust for a maximum output.	
2	Low-frequency range sensitivity adjustment	- do. -	- do. -	T101	Adjust for a maximum output at same tuning point under step 1.	
3	Local oscillator trimmer adjustment	- do. -	AM SG 1350KHz, 60dBμ	Tuning knob, Front-end Local oscillator Trimmer	Align pointer with 1350KHz using tuning knob, rotate trimmer and set for a maximum output.	
4	High-frequency range sensitivity adjustment	- do. -	- do. -	Front-end AM ANT. Trimmer	Set to for a maximum output at same tuning point under step 3.	
5	Sensitivity difference adjustment	- do. -	AM SG 600KHz 1350KHz 60dBμ	Repeat steps 1 to 4.		Scale deviation: Less than ±1.5mm for 600KHz and 1350KHz
6	Medium frequency range check	- do. -	AM SG 950KHz	Tuning knob	Set for a maximum point.	Scale deviation must be within ±2mm.

### 3. Audio section adjustment

Adjustment item	Terminals to be connected	Instrument required	Adjustment location	Adjustment method	Rating
DC offset voltage adjustment	L301–Earth (Lch) L302–Earth (Rch)	D.M	Main c. board 1 VR303 (Lch) VR304 (Rch)	Adjust deviation as specified.	$0 \pm 10$ mV

• Adjusting points

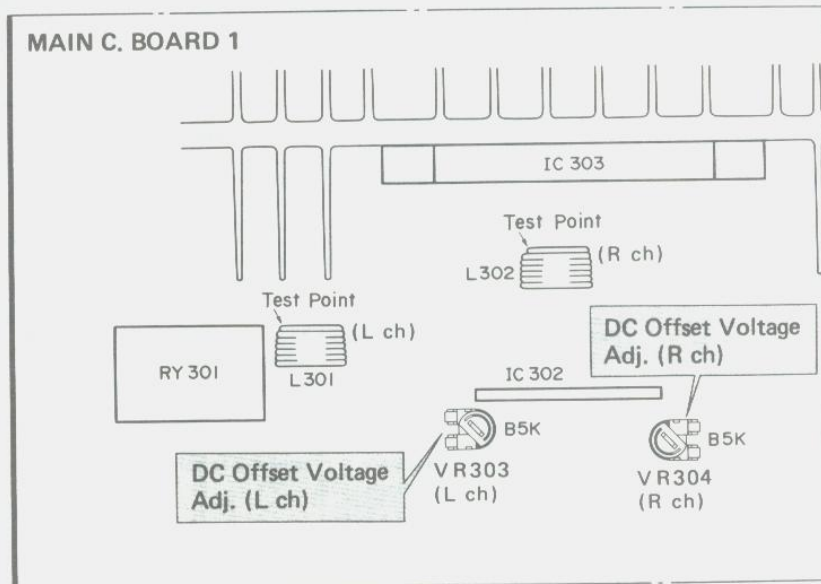

# CIRCUIT BOARDS

## TUNER C. BOARD-1 (Tuner)

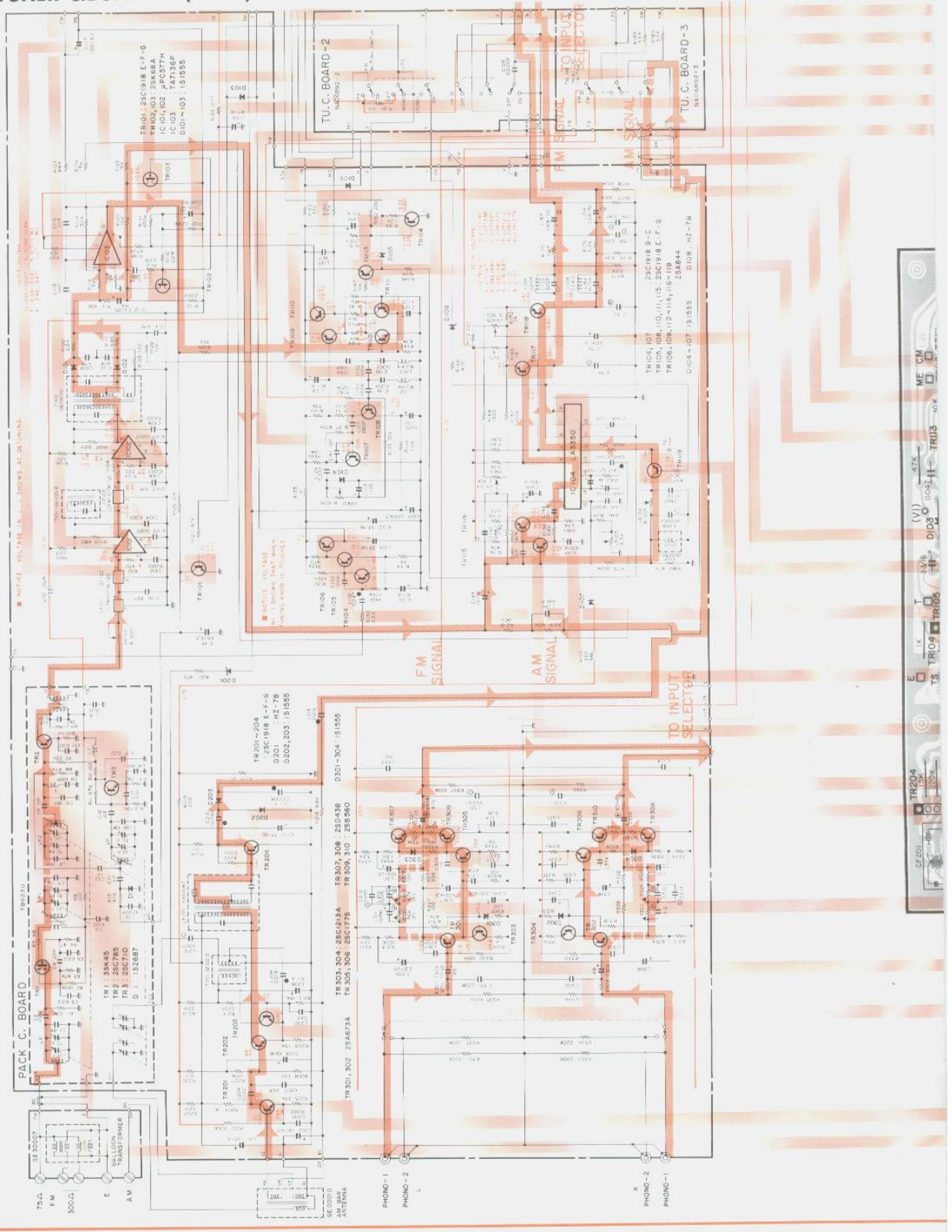







# PARTS LIST

## R-500

### STEREO RECEIVER

#### ■ CONTENTS

- EXPLODED VIEW ..... 1
- PARTS LIST (Mechanism) ..... 2
- PARTS LIST (Circuit Board)
  - Main Circuit Board ..... 4
  - Tuner Circuit Board ..... 7



R-500 ■ EXPLODED VIEW

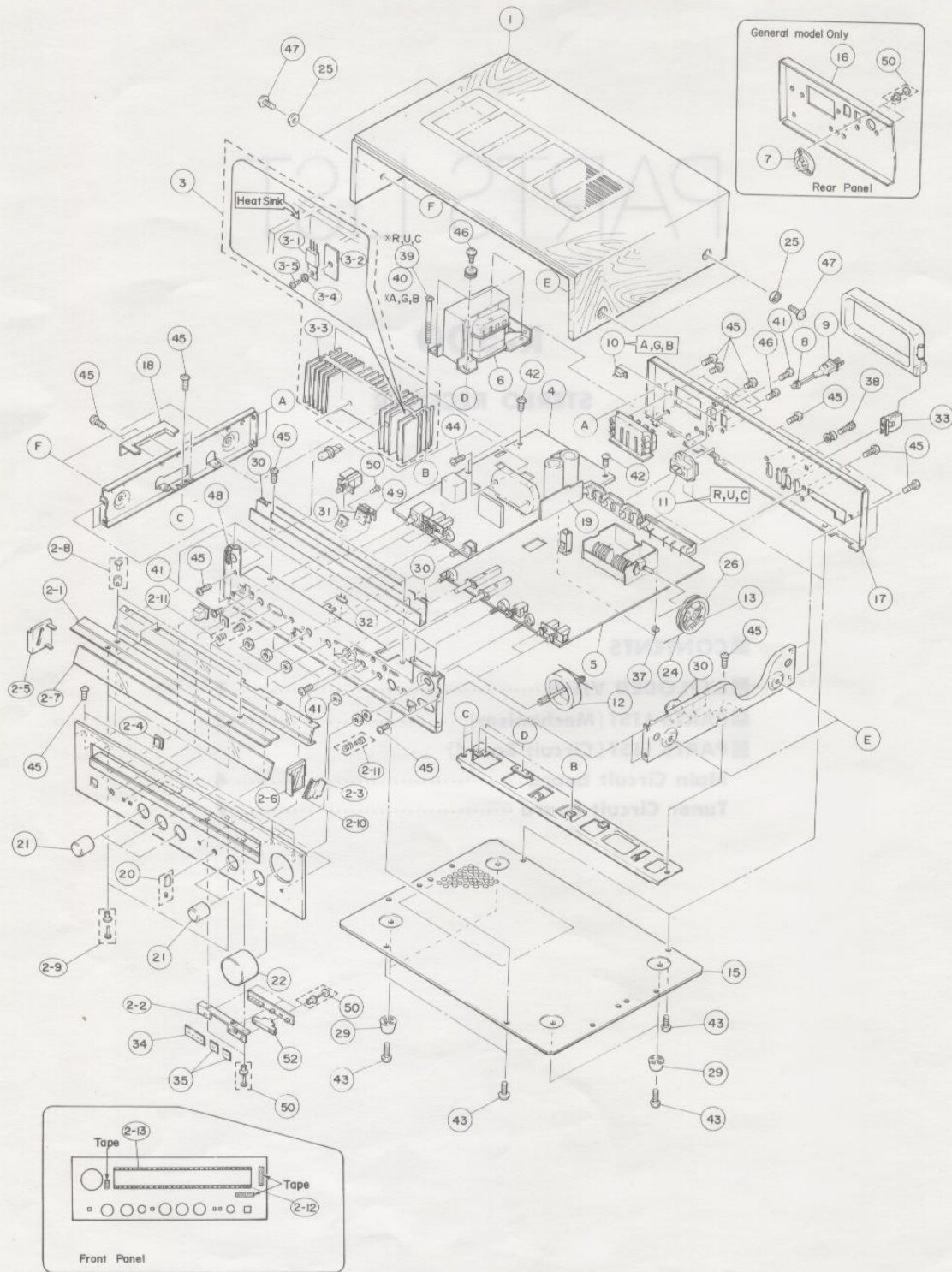

# PARTS LIST (Mechanism)

R-500

Ref. No.	Part No.	Description	(部 品 名)	Remarks	Common model	Markets
* 1	32:00:05 95:62:58:10	Cabinet	外装組立			R
* "	32:00:05 96:62:59:10	"	"			U
* "	32:00:05 96:62:60:10	"	"			C
* "	32:00:06 95:62:61:10	"	"			G,A,B
* "	32:00:05 96:62:61:20	" (Black model)	"	R-500B		G
* 2	32:00:00 NB:09:97:60	Panel Unit	パネルユニット			
* "	32:00:00 NB:09:97:70	" (Black model)	"	R-500B		G
* 2-1	32:00:00 AA:60:55:20	Sealing Plate	シーリングプレート			
* "	32:00:00 AA:60:57:20	" (Black model)	"	R-500B		G
* 2-2	32:00:00 AA:60:55:40	Holder for LED	LEDホルダー			
* 2-3	32:00:00 AA:60:55:60	Stopper	ストッパー			
* 2-4	32:00:00 CB:09:38:40	Frame, Power Button	パワーボタン枠			
* "	32:00:00 CB:09:38:80	" (Black model)	"	R-500B		G
* 2-5	32:00:00 CB:60:18:20	Side Cap (L)	サイドキャップ(L)			
* "	32:00:00 CB:60:20:50	" (Black model)	"	R-500B		
* 2-6	32:00:00 CB:60:18:30	Side Cap (R)	サイドキャップ(R)			
* "	32:00:00 CB:60:20:60	" (Black model)	"	R-500B		
* 2-7	32:00:00 CB:60:18:90	Dial Scale	ダイヤルスケール			
* 2-8	42:00:00 CB:06:88:80	Plastic Rivet (Black)	プラスチックリベット			
* 2-9	32:00:00 CB:08:37:30	" (Gray)	"			
* 2-10	42:00:00 CB:07:41:90	Adhesive Tape 5×36	ダブルタックテープ			
* 2-11	32:00:00 NB:09:39:20	Push Button Assembly	プッシュボタンAss'y		CR-440	
* "	32:00:00 NB:09:39:30	" (Black model)	"			
* 2-12	42:00:00 CB:07:42:00	Adhesive Tape (both face type)	ダブルタックテープ			
* 2-13	42:00:00 CB:07:41:90	"	"			
* 3	32:00:00 NB:09:97:80	Heat Sink Unit	放熱板ユニット			R,U,C
* "	32:00:00 NB:09:97:90	"	"			A,G,B
* 3-1	42:00:00 i D:10:52:10	Transistor 2SD1052A	トランジスタ	Inter-changeable Tr303		
* "	42:00:00 i C:19:83:00	" 2SC1983	"			
* 3-2	42:00:00 i L:00:02:70	Mica Base AC-229	マイカベース			
* 3-3	32:00:00 BA:08:02:60	Heat Sink	放熱板			R,U,C
* "	32:00:00 BA:08:02:70	"	"			A,G,B
* 3-4	32:00:00 CB:07:28:80	Isolation Bush	絶縁ブッシュ		CR-400	
* 3-5	42:00:00 EA:02:60:80	Pan Head Screw M2.6×8 (ZMC2-Y)	鉄ナベ小ネジ			
* 4	32:00:00 NA:07:59:50	Main Circuit Board	メインシート			R
* "	32:00:00 NA:07:59:60	"	"			U,C
* "	32:00:00 NA:07:59:70	"	"			A
* "	32:00:00 NA:07:59:80	"	"			G,B
* "	32:00:00 NA:07:59:90	"	"	R-500B		G
* 5	32:00:00 NA:07:60:40	Tuner Circuit Board	チューナシート			R
* "	32:00:00 NA:07:60:50	"	"			U,C
* "	32:00:00 NA:07:60:60	"	"			A,B
* "	32:00:00 NA:07:60:70	"	"			G
* 6	42:00:00 GA:64:07:00	Power Transformer	電源トランス			R
* "	42:00:00 GA:64:05:00	"	"			U
* "	42:00:00 GA:64:06:00	"	"			G
* "	42:00:00 GA:64:10:00	"	"			A,B
* "	42:00:00 GA:64:45:00	"	"			C
* 7	42:00:00 LB:20:14:80	Voltage Selector	電圧切換器			R
* 8	42:00:00 CB:06:86:30	Cord Stopper SR-3P-4	コードストッパー			U,C
* "	42:00:00 CB:07:27:50	" SR-4N-4	"			R,A,G,B
* 9	42:00:00 MG:00:07:80	Power Cord (Black) 2m 6A 250V	電源コード			R
* "	42:00:00 MG:00:08:40	" 10A 125V	"			U,C

\* : New Part (新部品)

DESTINATION ABBREVIATIONS J:Japan, R:General, U:U.S.A, C:Canadian, B:British, G:North European, A:Australian

Ref. No.	Part No.	Description	(部 品 名)	Remarks	Common model	Markets
9	42:00:00 MG:00:09:20	Power Cord (Gray) 2.5m 7.5A 250V	電源コード			A
"	42:00:00 MG:00:09:50	" 2m 2.5A 250V	"			G
"	42:00:00 MG:00:10:00	" (Black) 2m 6A 300/500V	"			B
10	42:00:00 LA:00:29:50	2P Terminal Board MA0092	2P中継端子台			A,G,B
11	42:00:00 LB:40:06:50	AC Outlet (double) M7013-A	ACアウトレット			R,U,C
※	12 32:00:00 NB:09:80:40	Tuning Unit	チューニングユニット			
13	32:00:00 AA:08:98:60	Spring for Dial	ダイヤルスプリング		CT-410 II CT-510	
※	14 32:00:00 AA:60:53:90	Rail, Pointer	指針レール			
※	15 32:00:00 AA:60:54:30	Bottom Cover	ボトムカバー			
※	16 32:00:00 AA:60:54:80	Rear Panel	リヤパネル			R
※	17 32:00:00 AA:60:54:90	"	"			U,C
※	" 32:00:00 AA:60:55:00	"	"			A,B
※	" 32:00:00 AA:60:55:10	"	"			G
18	32:00:00 AA:60:55:30	Radiator Holder	ラジエーターホルダー			
※	19 32:00:00 AA:60:55:50	Shield Plate	シールド板			R
20	32:00:00 BA:07:94:60	Knob, Switch (Silver)	SWツマミ		A-760	
※	" 32:00:00 BA:08:01:80	" (Black)	"	R-500B		G
※	21 32:00:00 BA:08:01:40	Knob (Silver)	ツマミ			
※	" 32:00:00 BA:08:01:70	" (Black)	"	R-500B		G
※	22 32:00:00 BA:08:01:60	Knob, Tuning (Silver)	チューニングツマミ			
※	" 32:00:00 BA:08:01:90	" (Black)	"	R-500B		G
23	42:00:00 CA:06:51:50	Isolation Fiber	絶縁ファイバー			
24	42:00:00 CB:07:70:70	Dial String $\phi 0.39 \times 170\text{cm}$	ダイヤル糸			
25	32:00:00 CB:07:95:20	Hole Cap	ホールキャップ			
26	32:00:00 CB:08:97:90	Pulley, Variable Capacitor	バリコンプーリー			
27	32:00:00 CB:09:34:50	Isolation Bush	絶縁ブッシュ			
28	32:00:00 CB:09:38:30	Button Power (Silver)	パワーボタン			
"	32:00:00 CB:09:38:70	" (Black)	"	R-500B		G
29	42:00:00 CB:09:86:00	Leg	脚			
30	32:00:00 CB:09:86:40	Wheel Ass'y	滑車Ass'y			
※	31 32:00:00 CB:60:18:00	Holder, Dial Pointer	指針ホルダー			
※	32 32:00:00 CB:60:19:10	Clip	クリップ			
※	33 32:00:00 CB:60:19:70	Holder, Antenna	アンテナホルダー			
※	34 42:00:00 CB:60:23:90	Tape	シャコウテープ(A)			
※	35 42:00:00 CB:60:24:00	"	" (B)			
37	32:00:00 CB:09:34:80	Spacer	スペーサー			
38	42:00:00 EZ:00:14:00	Screw, GND Terminal 3×13.5	アース端子ネジ	MFNi II		
39	42:00:00 ED:04:06:00	Bind Head Screw 4×60 (ZMC2-Y)	鉄バインド小ネジ			R,U,C
40	42:00:00 ED:04:07:50	" 4×75( " )	"			A,G,B
41	42:00:00 ED:03:00:60	" M3×6( " )	"	B-Tyte		
42	42:00:00 EK:03:00:60	BW Head Tapping Screw Type II 3×8 (ZMC2-Y)	鉄BWヘッドタッピンネジ			
43	42:00:00 EN:03:00:50	" 3×12 (2MC2-Y)	"			
44	42:00:00 EK:05:00:20	Pan Head Tap-Tyte Screw 3×16 (ZMC2-Y)	ナベタッパタイトネジ	B-Tyte		
45	42:00:00 EN:03:00:20	Bind Head Tapping Screw Type II 3×8 (ZMC2-Y)	鉄バインドタッピンネジ			
46	42:00:00 EK:03:00:50	" 4×8 (ZMC2-Y)	"			
47	42:00:00 ED:35:01:20	Bind Head Screw M5×12 (FCM3-B $\ell$ )	鉄バインド小ネジ			
※	48 32:00:00 AA:60:60:90	Reflector	反射板			
※	49 32:00:00 AA:60:66:10	Weight, Dialpointer	ウェイト			
50	42:00:00 CB:06:88:80	Plastic Rivet (Black)	プラスチックリベット			
51	42:00:00 CB:07:42:20	Adhesive Tape	ニットニトフロンテープ			
52	32:00:00 BB:06:94:50	LED Cover	LEDカバー			

※ : New Part (新部品)

# R-500 ■ PARTS LIST (Circuit Board)

Ref. No.	Part No.	Description	(部 品 名)	Remarks	Common model	Markets
※	32 00 00 NA 07 59 50	Main Circuit Board	メインシート			R
※	32 00 00 NA 07 59 60	"	"			U.C
※	32 00 00 NA 07 59 70	"	"			A
※	32 00 00 NA 07 59 80	"	"			G.B
※	32 00 00 NA 07 59 90	" (Black model)	"	R-500B		G
C301 C302	42 00 00 UW 84 64 70	Electrolytic Capacitor 4.7 $\mu$ F 25V	ケミコン			
C303 C304	42 00 00 UW 86 71 00	" 10 $\mu$ F 50V	"			
C305 C306	42 00 00 UW 84 64 70	" 4.7 $\mu$ F 25V	"			
C307 C308	42 00 00 FA 81 32 20	Mylar Capacitor 0.0022 $\mu$ F 50V(K)	マイラーコン			
C309 C310	42 00 00 UW 84 72 20	Electrolytic Capacitor 22 $\mu$ F 25V	ケミコン			
C311 C312	42 00 00 FA 85 46 80	Mylar Capacitor 0.068 $\mu$ F 50V(J)	マイラーコン			
C313 C314	42 00 00 FA 85 43 30	" 0.033 $\mu$ F "	"			
C315 C316	42 00 00 FG 41 24 70	Ceramic Capacitor 470PF 50V(K)	セラコン			
C317 C318	42 00 00 UW 86 71 00	Electrolytic Capacitor 10 $\mu$ F 50V	ケミコン			
C319 C320	42 00 00 UW 85 82 20	" 220 $\mu$ F 35V	"			
C321 C322	42 00 00 FG 41 15 60	Ceramic Capacitor 56PF 50V (K)	セラコン			
C323 C324	42 00 00 FG 41 06 00	" 6PF "	"			
C325 C326	42 00 00 UW 86 81 00	Electrolytic Capacitor 100 $\mu$ F 50V	ケミコン			
C327	42 00 00 UW 86 64 70	" 4.7 $\mu$ F 50V	"			
C328	42 00 00 UW 86 61 00	" 1 $\mu$ F 50V	"			
C329	42 00 00 UW 86 64 70	" 4.7 $\mu$ F 50V	"			
C330	42 00 00 UW 86 71 00	" 10 $\mu$ F 50V	"			
C331 C332	42 00 00 FG 41 13 30	Ceramic Capacitor 33PF 50V (K)	セラコン			
C333 C334	42 00 00 FG 41 12 70	" 27PF "	"			
C335 C338	42 00 00 FA 81 44 70	Mylar Capacitor 0.047 $\mu$ F 50V (K)	マイラーコン			
C339	42 00 00 FH 23 41 00	Ceramic Capacitor 0.01 $\mu$ F 500V YZ(P)	セラコン			
※ C340 C341	42 00 00 FZ 00 24 50	Electrolytic Capacitor 8200 $\mu$ F 50V	ブロックケミコン			
C342	42 00 00 UW 86 71 00	" 10 $\mu$ F 50V	ケミコン			
C343	42 00 00 UW 86 62 20	" 2.2 $\mu$ F 50V	"			
C344	42 00 00 UW 84 74 70	" 47 $\mu$ F 25V	"			
C345	42 00 00 UW 86 72 20	" 22 $\mu$ F 50V	"			
C346	42 00 00 UW 81 73 30	" 33 $\mu$ F 6.3V	"			
C347	42 00 00 UW 82 74 70	" 47 $\mu$ F 10V	"			
C348	42 00 00 UW 84 74 70	" 47 $\mu$ F 25V	"			
※ C349	42 00 00 Fi 34 41 00	Ceramic Capacitor 0.01 $\mu$ F MY(DE)	セラコン			R.U.C
※	42 00 00 FR 16 41 00	Metallized Paper Capacitor 0.01 $\mu$ F AC250V	MPコン			A.G.B
C351 C352	42 00 00 FA 81 32 20	Mylar Capacitor 0.0022 $\mu$ F 50V(K)	マイラーコン			
L301 L302	42 00 00 GD 90 03 40	Coil, output 1.5 $\mu$ H	アウトプットコイル			
R301 R302	42 00 00 HJ 35 51 00	Carbon Resistor RD25 SM-8 100 $\Omega$	カーボン抵抗			
R303 R304	42 00 00 HJ 35 91 00	" 1M $\Omega$	"			
R305 R306	42 00 00 HJ 35 84 70	" 470K $\Omega$	"			
R307 R310	42 00 00 HJ 35 58 20	" 820 $\Omega$	"			
R311 R312	42 00 00 HJ 35 84 70	" 470K $\Omega$	"			
R313 R316	42 00 00 HJ 35 68 20	" 8.2K $\Omega$	"			
R317 R318	42 00 00 HJ 35 54 70	" 470 $\Omega$	"			
R319 R320	42 00 00 HJ 35 61 50	" 1.5K $\Omega$	"			
R321 R322	42 00 00 HJ 35 62 20	" 2.2K $\Omega$	"			
R323 R324	42 00 00 HJ 35 52 20	" 220 $\Omega$	"			
R325 R326	42 00 00 HJ 35 62 20	" 2.2K $\Omega$	"			
R327 R328	42 00 00 HV 55 43 30	Flame proof Carbon Resistor 33 $\Omega$	"			

※ : New Part (新部品)

R-500

Ref. No.	Part No.	Description	(部 品 名)	Remarks	Common model	Markets	
* R329 R330	42 00 00 HZ 00 14 70	Dual Metal Plate Resistor RGC33 3P 0.47Ω	デュアル金属板抵抗				
* R331	42 00 00 HV 55 41 50	Flame Proof Carbon Resistor (J) 15Ω	不燃化カーボン抵抗				
R333 R334	42 00 00 HJ 35 71 80	Carbon Resistor RD25 SM-8 18KΩ	カーボン抵抗				
R335 R336	42 00 00 HJ 35 64 70	" 4.7KΩ	"				
R337 R338	42 00 00 HJ 35 71 80	" 18KΩ	"				
R339 R340	42 00 00 HJ 35 72 20	" 22KΩ	"				
R341 R342	42 00 00 HL 81 34 70	Oxide Metal Film Resistor 1P 4.7Ω	酸化抵抗				
R343 R344	42 00 00 HJ 35 81 00	Carbon Resistor RD25 SM-8 100KΩ	カーボン抵抗				
R345 R346	42 00 00 HL 82 52 20	Oxide Metal Film Resistor 2P 220Ω	酸化抵抗				
* R347 R348	42 00 00 HV 55 33 30	Flame Proof Carbon Resistor (J) 3.3Ω	不燃化カーボン抵抗				
R349	42 00 00 HJ 35 61 80	Carbon Resistor RD25, SM-8 1.8KΩ	カーボン抵抗				
R350	42 00 00 HJ 35 62 20	" 2.2KΩ	"				
* R351	42 00 00 HL 82 61 00	Oxide Metal Film Resistor 2P 1KΩ	酸化抵抗				
R352	42 00 00 HJ 35 64 70	Carbon Resistor RD25, SM-8 4.7KΩ	カーボン抵抗				
R353	42 00 00 HV 55 58 20	Flame Proof Carbon Resistor (J) 820Ω	不燃化カーボン抵抗				
R354	42 00 00 HJ 35 71 50	Carbon Resistor RD25, SM-8 15KΩ	カーボン抵抗				
R355	42 00 00 HJ 35 83 90	" 390KΩ	"				
R356	42 00 00 HJ 35 73 90	" 39KΩ	"				
R357	42 00 00 HJ 35 84 70	" 470KΩ	"				
R358	42 00 00 HJ 35 76 80	" 68KΩ	"				
R359	42 00 00 HJ 35 64 70	" 4.7KΩ	"				
R360	42 00 00 HJ 35 71 00	" 10KΩ	"				
R361	42 00 00 HJ 35 78 20	" 82KΩ	"				
R362	42 00 00 HG 30 92 20	Carbon Resistor RD50S (J) 2.2MΩ	"				
* VR301	42 00 00 HS 31 11 80	Variable Resistor CS 30KB×2	VRφ16 2連11点クリック	} Inter-changeable			
* "	42 00 00 HS 41 11 20	" " "	"				
* VR302	42 00 00 HS 31 13 40	" CT 20KG×2	"	}			
* "	42 00 00 HS 41 11 10	" " 20KW×2	"				
VR303 VR304	42 00 00 HT 37 00 50	Semi Variable Resistor EVN-K4A B5KΩ	半固定VR	}			
"	42 00 00 HT 77 00 50	" KVSF8-7PNFX B5KΩ	"				
TR301 TR302	42 00 00 i C 22 40 00	Transistor 2SC2240 (GR, BL)	トランジスタ	} Inter-changeable			
"	42 00 00 i C 20 88 00	" 2SC2088 (BL, V)	"				
TR304 306	42 00 00 i C 23 20 10	" 2SC2320 (E, F)	"	}			
TR307	42 00 00 i A 09 99 10	" 2SA999 (E, F)	"				
TR308	42 00 00 i C 23 20 10	" 2SC2320 (E, F)	"				
TR309	42 00 00 i A 09 99 10	" 2SA999 (E, F)	"				
D301 D302	42 00 00 i F 00 00 40	Diode IS1555	ダイオード		}		
D303 D304	42 00 00 i H 00 07 10	" W06C	"				
* D305	42 00 00 i F 00 25 10	Zener Diode HZ-24-3	ツェナーダイオード	}			
* D306	42 00 00 i F 00 25 00	" HZ-16-2	"				
* D307 D308	42 00 00 i F 00 24 90	" HZ-9A-2	"	}			
D309	42 00 00 i H 00 07 10	Diode W06C	ダイオード				
D310	42 00 00 i F 00 00 40	" IS1555	"	}			
* D311	42 00 00 i H 00 10 40	Bridge Diode RB402	ダイオードブリッジ				
"	42 00 00 i H 00 08 70	" 4D4B41	"		} Inter-changeable		
"	42 00 00 i H 00 10 80	" DBA40C	"				
"	42 00 00 i H 00 10 90	" S4VB	"				
* IC301	42 00 00 i G 04 00 00	IC NJM4560	IC				

\* : New Part (新部品)

Ref. No.	Part No.	Description	(部 品 名)	Remarks	Common model	Markets
* IC302	42:00:00 i G 04:72:00	IC STK-3042 II	IC			
* IC303	42:00:00 i G 04:71:00	" STK-2040	"			
* PL301	42:00:00 JB:00:09:40	Lamp lead-Type 28V 100mA	パイロットランプリード式			
* SW301	42:00:00 KA:80:23:40	Push Switch SUF TWO-way Switch×2 h=12.5	ブッシュSW			
* SW302	42:00:00 KA:80:23:90	Push Switch SDV single-pole ℓ=20	"			U.C
* "	42:00:00 KA:80:23:30	" SDS	"			R.A.G.B
F301	42:00:00 KB:00:03:50	Fuse T2A 250V	ヒューズ			R.A
"	42:00:00 KB:00:16:60	" S T1.6A 250V	"			G.B
* "	42:00:00 KB:00:25:70	" UL ST-4 4.0A 250V	"			U.C
F302	42:00:00 KB:00:03:80	" T4.0A 250V	"			R
* RY301	42:00:00 KC:00:11:30	Relay JC2a DC24V	リレー			R.A.G.B
* "	42:00:00 KC:00:11:50	" "	"			U.C
* JK301	42:00:00 LB:30:13:60	Jack, Headphones (Gray)	ヘッドホンジャック			R.U.A.G.C.B
* "	42:00:00 LB:30:13:70	" (Black)	"		R-500B	G
* "	32:00:00 MZ:07:99:20	Main Connector Assembly	メインコネクターAss'y		R-300	
"	32:00:00 BB:06:83:70	Earth Plate	アース金具			
"	42:00:00 LA:00:23:20	Wrapping Terminal i-Type P=7.5 3P	i型ラッピング端子板			
"	42:00:00 LA:00:21:40	" " P=10 2P	"			R.A.G.B
"	42:00:00 LA:00:25:90	" " P=10(O) 3P	"			U.C
"	42:00:00 LB:20:09:00	Fuse Holder Pin YSH402P	ヒューズホルダーピン			R.U.A.C
"	42:00:00 LB:20:10:60	" "	"			G.B
* "	42:00:00 LA:00:34:50	Push Terminal 8P	8Pブッシュターミナル			

\* : New Part (新部品)

R-500

Ref. No.	Part No.	Description	(部 品 名)	Remarks	Common model	Markets
* 32:00:00	NA 07 60:40	Tuner Circuit Board	チューナシート			R
* 32:00:00	NA 07 60:50	"	"			U,C
* 32:00:00	NA 07 60:60	"	"			A,B
* 32:00:00	NA 07 60:70	"	"			G
C101	42:00:00 UW84 71:00	Electrolytic Capacitor 10 $\mu$ F 25V	ケミコン			
C102	42:00:00 Fi 17 41:00	Ceramic Capacitor 0.01 $\mu$ F	セラコン			
C103	42:00:00 UW83 71:00	Electrolytic Capacitor 10 $\mu$ F 16V	ケミコン			
C104 -106	42:00:00 Fi 17 41:00	Ceramic Capacitor 0.01 $\mu$ F	セラコン			
C107 C108	42:00:00 Fi 17 14:70	" 47PF	"			
C109	42:00:00 UW81 81:00	Electrolytic Capacitor 100 $\mu$ F 6.3V	ケミコン			
C110	42:00:00 FS:25 23:30	Semi-Conductive Ceramic Capacitor 330PF 50V (J)	フォーミングSAコン			
C111	42:00:00 FG:41 11:00	Ceramic Capacitor 10PF (K)	セラコン			
C112 -118	42:00:00 Fi 17 41:00	" 0.01 $\mu$ F	"			
C119	42:00:00 UW83 71:00	Electrolytic Capacitor 10 $\mu$ F 16V	ケミコン			
C120	42:00:00 UW83 73:30	" 33 $\mu$ F 16V	"			
C121	42:00:00 UW86:61:00	" 1 $\mu$ F 50V	"			
C122	42:00:00 UW83 71:00	" 10 $\mu$ F 16V	"			
C123	42:00:00 Fi 17 14:70	Ceramic Capacitor 47PF	セラコン			
C124	42:00:00 Fi 17 41:00	" 0.01 $\mu$ F	"			
C125	42:00:00 Fi 17 42:20	" 0.022 $\mu$ F	"			
C126	42:00:00 UW83 71:00	Electrolytic Capacitor 10 $\mu$ F 16V	ケミコン			
C127	42:00:00 FG:44 42:20	Ceramic Capacitor 0.022 $\mu$ F 50V (Z)	セラコン			
C128	42:00:00 UW86:61:00	Electrolytic Capacitor 1 $\mu$ F 50V	ケミコン			
C129	42:00:00 UW81 81:00	" 100 $\mu$ F 6.3V	"			
C130	42:00:00 UW83 71:00	" 10 $\mu$ F 16V	"			
C131	42:00:00 UW86 62:20	" 2.2 $\mu$ F 50V	"			
C132 -134	42:00:00 UW83 71:00	" 10 $\mu$ F 16V	"			
C135	42:00:00 Fi 17 34:70	Ceramic Capacitor 0.0047 $\mu$ F	セラコン			
C136	42:00:00 Fi 17 32:20	" 0.0022 $\mu$ F	"			
C137 C138	42:00:00 Fi 17 21:00	" 100PF	"			
C139	42:00:00 Fi 17 11:00	" 10PF	"			
C140	42:00:00 UW86:61:00	Electrolytic Capacitor 1 $\mu$ F 50V	ケミコン			
C141	42:00:00 Fi 17 41:00	Ceramic Capacitor 0.01 $\mu$ F	セラコン			
C142	42:00:00 Fi 17 34:70	" 0.0047 $\mu$ F	"			
C143 C144	42:00:00 FS:25 24:70	Semi-Conductive Ceramic Capacitor 470PF 50V (J)	フォーミングSAコン			
C145 C146	42:00:00 FS:25 22:70	" 270PF "	"			R,U,C
C147 C148	42:00:00 Fi 17 34:70	Ceramic Capacitor 0.0047 $\mu$ F	セラコン			
C149 C150	42:00:00 Fi 17 32:20	" 0.0022 $\mu$ F	"			
C151 C152	42:00:00 UW86:61:00	Electrolytic Capacitor 1 $\mu$ F 50V	ケミコン			
C153	42:00:00 FA:85 41:00	Mylar Capacitor 0.01 $\mu$ F 50V (J)	マイラーコン			
C154 C155	42:00:00 Fi 17 41:00	Ceramic Capacitor 0.01 $\mu$ F	セラコン			
C156	42:00:00 UW86:61:00	Electrolytic Capacitor 1 $\mu$ F 50V	ケミコン			
C157	42:00:00 FS:25 26:80	Semi-Conductive Ceramic Capacitor 680PF 50V (J)	フォーミングSAコン			
C158	42:00:00 Fi 17 41:00	Ceramic Capacitor 0.01 $\mu$ F	セラコン			
* C159	42:00:00 UW86 52:20	Electrolytic Capacitor 0.22 $\mu$ F 50V	ケミコン			
C160	42:00:00 UW83 71:00	" 10 $\mu$ F 16V	"			
C161	42:00:00 Fi 17 41:00	Ceramic Capacitor 0.01 $\mu$ F	セラコン			
C162	42:00:00 UW86:61:00	Electrolytic Capacitor 1 $\mu$ F 50V	ケミコン			
C163	42:00:00 UW83 71:00	" 10 $\mu$ F 16V	"			
C164	42:00:00 UW84 71:00	" 10 $\mu$ F 25V	"			
C165 C166	42:00:00 UW84 61:00	" 1 $\mu$ F 25V	"			
C167 C168	42:00:00 FG:41 22:20	Ceramic Capacitor 220PF 50V (K)	セラコン			
C169 C170	42:00:00 FG:41 21:00	" 100PF "	"			

\* : New Part (新部品)

Ref. No.	Part No.	Description	(部 品 名)	Remarks	Common model	Markets
C171	42 00 00 UW:81 81 00	Electrolytic Capacitor 100 $\mu$ F 6.3V	ケミコン			
C172	42 00 00 FA:85 45 60	Mylar Capacitor 0.056 $\mu$ F 50V (J)	マイラーコン			
C173	42 00 00 FA:85 41 00	" 0.016 $\mu$ F "	"			
C174	42 00 00 FG:41 11 00	Ceramic Capacitor 10PF 50V (K)	セラコン			
C175	42 00 00 FG:41 13 30	" 33PF "	"			
C176	42 00 00 UW:86 64 70	Electrolytic Capacitor 4.7 $\mu$ F 50V	ケミコン			
C177	42 00 00 FA 81 35 60	Mylar Capacitor 0.0056 $\mu$ F 50V (K)	マイラーコン			
C178	42 00 00 FA 85 42 20	" 0.022 $\mu$ F 50V (J)	"			
C179	42 00 00 FG:41 22 70	Ceramic Capacitor 270PF 50V (K)	セラコン			
C180	42 00 00 UW:84 74 70	Electrolytic Capacitor 47 $\mu$ F 25V	ケミコン			
C181	42 00 00 FG:44 41 00	Ceramic Capacitor 0.01 $\mu$ F 50V (Z)	セラコン			
C182	42 00 00 UW:86 61 00	Electrolytic Capacitor 1 $\mu$ F 50V	ケミコン			
C183	42 00 00 UW:84 74 70	" 47 $\mu$ F 25V	"			
C184	42 00 00 FH 23 41 00	Ceramic Capacitor 0.01 $\mu$ F 500V YZ(P)	セラコン			
C185	42 00 00 UW 83 81 00	Electrolytic Capacitor 100 $\mu$ F 16V	ケミコン			
C186	42 00 00 UW 83 71 00	" 10 $\mu$ F 16V	"			
C187	42 00 00 FY 00 01 10	Trimmer Capacitor TRC-1T8 $\times$ 10 BP	トリマーコン			
C188	42 00 00 GE 10 03 30	FM Discriminator Coil GE10033	FMディスクリコイル			
C189	42 00 00 GE 10 05 10	AM ANTENNA Coil GE10051	AM ANTコイル			
C190	42 00 00 GE 10 01 50	AM OSC Coil GE6013	AM OSCコイル			
C191	42 00 00 GE 10 04 70	AM IF Coil GE10047	AM IFコイル			
C192	42 00 00 GE 30 01 50	RF Inductor 8.2mH	RFインダクター			
C193	42 00 00 GE 30 02 40	" 10 $\mu$ H	"			
C194	42 00 00 GE 30 01 50	" 8.2mH	"			
C195	42 00 00 GE 30 04 50	Inductor 1mH	円筒形インダクター			
C196	42 00 00 GG 00 04 80	Ceramic Filter SFE10.7 MA8-Z	セラミックフィルター			R,U,A,C,B
C197	42 00 00 GG 00 04 30	" CFM-107S-12C	"			G
C198	42 00 00 GG 00 04 40	" SFZ-450G	"			
C199	42 00 00 HJ 35 53 30	Carbon Resistor RD25, SM-8 330 $\Omega$	カーボン抵抗			R,U,A,C,B
C200	42 00 00 HJ 35 51 00	" 100 $\Omega$	"			G
C201	42 00 00 HJ 35 63 30	" 3.3K $\Omega$	"			
C202	42 00 00 HJ 35 51 00	" 100 $\Omega$	"			
C203	42 00 00 HJ 35 61 80	" 1.8K $\Omega$	"			
C204	42 00 00 HJ 35 53 30	" 330 $\Omega$	"			R,U,A,C,B
C205	42 00 00 HJ 35 54 70	" 470 $\Omega$	"			G
C206	42 00 00 HJ 35 52 20	" 220 $\Omega$	"			
C207	42 00 00 HJ 35 53 30	" 330 $\Omega$	"			R,U,A,C,B
C208	42 00 00 HJ 35 54 70	" 470 $\Omega$	"			G
C209	42 00 00 HJ 35 52 20	" 220 $\Omega$	"			
C210	42 00 00 HJ 35 66 80	" 6.8K $\Omega$	"			
C211	42 00 00 HJ 35 52 20	" 220 $\Omega$	"			
C212	42 00 00 HJ 35 66 80	" 6.8K $\Omega$	"			
C213	42 00 00 HJ 35 71 00	" 10K $\Omega$	"			G
C214	42 00 00 HJ 35 71 50	" 15K $\Omega$	"			R,U,A,C,B
C215	42 00 00 HJ 35 62 20	" 2.2K $\Omega$	"			
C216	42 00 00 HJ 35 52 20	" 220 $\Omega$	"			
C217	42 00 00 HJ 35 71 00	" 10K $\Omega$	"			
C218	42 00 00 HJ 35 76 80	" 68K $\Omega$	"			
C219	42 00 00 HJ 35 74 70	" 47K $\Omega$	"			

※ : New Part (新部品)

R-500

Ref. No.	Part No.		Description	(部 品 名)	Remarks	Common model	Markets
R120	42:00:00	HJ:35:71:00	Carbon Resistor RD25, SM-8	10KΩ	カーボン抵抗		
R121	42:00:00	HJ:35:92:20	"	2.2MΩ	"		
R122	42:00:00	HJ:35:63:30	"	3.3KΩ	"		
R123	42:00:00	HJ:35:61:00	"	1KΩ	"		
R124 R125	42:00:00	HJ:35:81:00	"	100KΩ	"		
R126 R127	42:00:00	HJ:35:61:00	"	1KΩ	"		
R128	42:00:00	HJ:35:74:70	"	47KΩ	"		
R129	42:00:00	HJ:35:81:00	"	100KΩ	"		
R130	42:00:00	HJ:35:71:50	"	15KΩ	"		
R131	42:00:00	HJ:35:63:90	"	3.9KΩ	"		
R132	42:00:00	HJ:35:63:30	"	3.3KΩ	"		
R133	42:00:00	HJ:35:76:80	"	68KΩ	"		
R134	42:00:00	HJ:35:73:30	"	33KΩ	"		
R135	42:00:00	HJ:35:71:00	"	10KΩ	"		
R136 R137	42:00:00	HJ:35:81:00	"	100KΩ	"		
R138	42:00:00	HJ:35:62:20	"	2.2KΩ	"		
R139	42:00:00	HJ:35:81:00	"	100KΩ	"		
R140	42:00:00	HJ:35:51:00	"	100Ω	"		
R141 R142	42:00:00	HJ:35:74:70	"	47KΩ	"		
R143 R144	42:00:00	HJ:35:71:00	"	10KΩ	"		
R145 R146	42:00:00	HJ:35:74:70	"	47KΩ	"		G
"	42:00:00	HJ:35:75:10	"	51KΩ	"		R,U,A,C,B
R147 R148	42:00:00	HJ:35:71:00	"	10KΩ	"		
R149 R150	42:00:00	HJ:35:81:00	"	100KΩ	"		
R151 R152	42:00:00	HJ:35:42:20	"	22Ω	"		
R153 R154	42:00:00	HJ:35:63:30	"	3.3KΩ	"		
R155 R156	42:00:00	HJ:35:66:80	"	6.8KΩ	"		
R157 -160	42:00:00	HJ:35:71:00	"	10KΩ	"		
R161	42:00:00	HJ:35:61:00	"	1KΩ	"		
R162	42:00:00	HJ:35:72:20	"	22KΩ	"		
R163	42:00:00	HJ:35:81:00	"	100KΩ	"		
R164	42:00:00	HJ:35:71:50	"	15KΩ	"		
R165	42:00:00	HJ:35:73:30	"	33KΩ	"		
R166	42:00:00	HJ:35:72:20	"	22KΩ	"		
R167	42:00:00	HJ:35:61:00	"	1KΩ	"		
R168	42:00:00	HJ:35:74:70	"	47KΩ	"		
R169	42:00:00	HJ:35:81:00	"	100KΩ	"		
R170	42:00:00	HJ:35:61:00	"	1KΩ	"		
R172	42:00:00	HJ:35:84:70	Carbon Resistor RD25, SM-8	470KΩ	カーボン抵抗		
R173	42:00:00	HJ:35:71:00	"	10KΩ	"		
R174	42:00:00	HJ:35:82:20	"	220KΩ	"		
R175	42:00:00	HJ:35:71:00	"	10KΩ	"		
R176	42:00:00	HJ:35:74:70	"	47KΩ	"		
R177	42:00:00	HJ:35:52:20	"	220Ω	"		
R178 R179	42:00:00	HJ:35:71:00	"	10KΩ	"		
R180	42:00:00	HJ:35:72:20	"	22KΩ	"		
R181	42:00:00	HJ:35:66:80	"	6.8KΩ	"		
R182	42:00:00	HJ:35:52:70	"	270Ω	"		
R183 -185	42:00:00	HJ:35:71:00	"	10KΩ	"		
R187	42:00:00	HJ:35:51:50	Carbon Resistor RD25, SM-8	150Ω	カーボン抵抗		
R188	42:00:00	HJ:35:61:00	"	1KΩ	"		

\* : New Part (新部品)

Ref. No.	Part No.	Description	(部 品 名)	Remarks	Common model	Markets
R189	42:00:00 HJ 35 51 80	Carbon Resistor RD25, SM-8	150Ω	カーボン抵抗		
R190	42:00:00 HJ 35 54 70	"	470Ω	"		
R191 ~195	42:00:00 HJ 35 56 80	"	680Ω	"		
R196	42:00:00 HJ 35 61 50	"	1.5KΩ	"		
R197	42:00:00 HJ 35 73 30	"	33KΩ	"		
R198	42:00:00 HJ 35 62 20	"	2.2KΩ	"		
R199	42:00:00 HJ 35 62 70	"	2.7KΩ	"		
R200	42:00:00 HJ 35 84 70	"	470KΩ	"		
R201 R202	42:00:00 HJ 35 75 60	"	56KΩ	"		
R203 R204	42:00:00 HJ 35 51 50	"	150Ω	"		
R205 R206	42:00:00 HJ 35 72 20	"	22KΩ	"		
R207 R208	42:00:00 HJ 35 51 30	"	130Ω	"		
R209 R210	42:00:00 HJ 35 75 60	"	56KΩ	"		
R211 R212	42:00:00 HJ 35 64 70	"	4.7KΩ	"		
R213 R214	42:00:00 HJ 35 51 00	"	100Ω	"		
R215 R216	42:00:00 HJ 35 54 70	"	470Ω	"		
R217 R218	42:00:00 HJ 35 81 00	"	100KΩ	"		
R221 R222	42:00:00 HJ 35 66 80	Carbon Resistor RD25, SM-8	6.8KΩ	カーボン抵抗		
R223 R224	42:00:00 HJ 35 71 50	"	15KΩ	"		
R225 R226	42:00:00 HJ 35 75 60	"	56KΩ	"		
R227 R228	42:00:00 HJ 35 82 20	"	220KΩ	"		
R229 R230	42:00:00 HJ 35 76 80	"	68KΩ	"		
R231 R232	42:00:00 HJ 35 88 20	"	820KΩ	"		
R233 R234	42:00:00 HJ 35 82 20	"	220KΩ	"		
R235 R236	42:00:00 HJ 35 76 80	"	68KΩ	"		
R237 R238	42:00:00 HJ 35 88 20	"	820KΩ	"		
R240	42:00:00 HJ 35 51 00	Carbon Resistor RD25, SM-8	100Ω	カーボン抵抗		
R241	42:00:00 HJ 35 61 20	"	1.2KΩ	"		
R242	42:00:00 HJ 35 72 20	"	22KΩ	"		
R243	42:00:00 HJ 35 82 20	"	220KΩ	"		
R244	42:00:00 HV 55 41 00	Flame Proof Carbon Resistor	RDF 25SW 10Ω	不燃化カーボン抵抗		
VR101	42:00:00 HT 37 00 20	Semi Variable Resistor	EVN-K4A B10Ω	半固定VR	} Inter- changeable	
"	42:00:00 HT 77 00 60	"	KVSF8-7PNFX B10KΩ	"		
VR102 VR103	42:00:00 HT 37 00 30	"	EVN-K4A B100KΩ	"		
"	42:00:00 HT 37 00 90	"	KVSF8-7PNFX B100KΩ	"		
VR104	42:00:00 HT 37 00 60	"	EVN-K4A B2KΩ	"		
"	42:00:00 HT 77 00 40	"	KVSF8-7PNFX B2KΩ	"		
VR105	42:00:00 HS 31 08 90	Variable Resistor	Center-Click 250KBH×2	VR φ16 2連	} "	
"	42:00:00 HS 41 11 00	"	250KMN×2	"		
VR106	42:00:00 HS 31 11 70	"	150KB×2	"		
"	42:00:00 HS 41 10 90	"	"	"		
VR107	42:00:00 HS 31 13 20	"	100KA×2	"	} "	
"	42:00:00 HS 41 11 40	"	"	"		
TR101 104	42:00:00 i C 23 20 10	Transistor	2SC2320 (E,F)	トランジスタ		
TR105 110	42:00:00 i A 09 99 10	"	2SA999 (E,F)	"		
TR111 116	42:00:00 i C 23 20 10	"	2SC2320 (E,F)	"		
TR117	42:00:00 i A 09 99 10	"	2SA999 (E,F)	"		
TR118	42:00:00 i C 23 20 10	"	2SC2320 (E,F)	"		

\* : New Part (新部品)

R-500

Ref. No.	Part No.	Description	(部 品 名)	Remarks	Common model	Markets
* TR119	42:00:00 i D:10:52:10	Transistor 2SD1052A	トランジスタ	} Inter-changeable		
"	42:00:00 i C:19:83:00	" 2SC1983	"			
D101-108	42:00:00 i F:00:00:40	Diode 1S1555	ダイオード			
* D109	42:00:00 i F:00:24:60	LED (Red) SLJ265UR	LED (赤)			
* D110	42:00:00 i F:00:24:50	" (Green) SLJ265GG	" (緑)			
D111	42:00:00 i F:00:14:80	LED Pointer LS003E	LED指針			
* D112	42:00:00 i F:00:24:70	LED (Green) SLJ265GG	LED 5連 (緑)			
IC101	42:00:00 i G:03:45:00	IC //PC577H (F)	IC			
IC102	42:00:00 i G:02:92:00	" #2920	"			
IC103	42:00:00 i G:03:21:00	" #3210	"			
IC104	42:00:00 i G:03:17:00	" LA1240	"			
IC105-106	42:00:00 i G:03:49:00	" M5214L	"			
* IC107	42:00:00 i G:04:68:00	LED Driver BA6104	LEDドライバー			
* SW101	42:00:00 KA:50:16:20	Rotary Switch SRZ-S 4-Circuit 6-Point	ロータリーSW			
* SW102	42:00:00 KA:50:16:10	" NS 4-Circuit 5-Point	"			
* SW103	42:00:00 KA:80:23:50	Push Switch SUF NS 2-Circuit 2-Point	プッシュスイッチ			
* SW104	42:00:00 KA:80:23:70	" "	"			
* 32:00:00	AA:60:69:30	Shield Plate	シールド板			
* PJ101-103	42:00:00 LB:40:08:10	4P Pin Jack	4Pピンジャック			
* PK101	42:00:00 PA:00:05:80	Front End Pack FE176U	フロントエンドパック			
32:00:00	BA:07:72:90	Heat Sink	放熱板			
42:00:00	EN:03:00:10	Bind Head Tapping Screw 3x6 (ZMC2-Y)	鉄バインドタッピンネジ	Type-II		
42:00:00	LA:00:27:70	5P Antenna Terminal	5Pアンテナ端子板			
42:00:00	LB:50:03:80	DIN Connector Socket M0086	DINコネクタソケット			
42:00:00	LB:00:30:50	Jumper Socket 5P	ジャンパーソケット			
42:00:00	Mi:06:96:20	Ribbon Wire 4P $\ell=400$	リボンワイヤー			
32:00:00	BB:06:83:70	Metal Fitting	アース金具			
* 32:00:00	BB:06:94:60	IC Shield Cover	ICシールド金具			

\* : New Part (新部品)