

Service Manual

QUARTZ Synthesizer
AM/FM Stereo Receiver

Receiver

SA-GX500



Color

(K)... Black Type

Area

Country Code	Area	Color
(PP)	U.S.A. and Canada.	(K)

⚠ WARNING

This service literature is designed for experienced repair technicians only and is not designed for use by the general public. It does not contain warnings or cautions to advise non-technical individuals of potential dangers in attempting to service a product. Products powered by electricity should be serviced or repaired only by experienced professional technicians. Any attempt to service or repair the product or products dealt with in this service literature by anyone else could result in serious injury or death.

SPECIFICATIONS (IHF'78)

■ AMPLIFIER SECTION

**Rated minimum sine wave
RMS power output**
20 Hz~20 kHz both channels driven
0.008% total harmonic distortion
80 W per channel (8 ohms)

1 kHz continuous power output
both channels driven
0.008% total harmonic distortion 82 W per channel (8 ohms)
Dynamic headroom 1.2 dB (8 ohms)
Total harmonic distortion
rated power at 20 Hz~20 kHz 0.008% (8 ohms)
half power at 1 kHz 0.002% (8 ohms)
SMPTF intermodulation distortion 0.01% (8 ohms)

Frequency response
PHONO RIAA standard curve ±0.8 dB
CD, VCR 1, VCR 2, TAPE 7 Hz~70 kHz, ±3 dB
Input sensitivity
PHONO 0.4 mV (3 mV, IHF '66)
CD, VCR 1, VCR 2, TAPE 27 mV (200 mV, IHF '66)
S/N (IHF, A)
PHONO 70 dB (80 dB, IHF '66)
CD, VCR 1, VCR 2, TAPE 70 dB (90 dB, IHF '66)

Maximum input voltage
PHONO 160 mV (IHF '66)

Input impedance
PHONO 47 kilohms
CD, VCR 1, VCR 2, TAPE 22 kilohms

Tone controls
BASS 50 Hz, +10 dB~-10 dB
TREBLE 20 kHz, +10 dB~-10 dB

Parametric equalizer +10 dB~-10 dB
Loudness control (volume at -30 dB) 50 Hz, +9 dB
Low frequency damping factor 20 (8 ohms)
Load impedance
A or B 8~16 ohms
A and B 8~16 ohms

■ REAR AMPLIFIER SECTION

Power output at 1 kHz (8 ohms) 2 × 15 W
(T.H.D 0.8%)

■ FM TUNER SECTION

Frequency range 87.9~107.9 MHz
Sensitivity 11.2 dBf (2 μV, IHF '58)
50 dB quieting sensitivity
MONO 20.2 dBf (5.6 μV, IHF '58)
STEREO 40.2 dBf (56 μV, IHF '58)
Total harmonic distortion 0.2% (MONO), 0.3% (STEREO)
S/N
MONO 75 dB
STEREO 70 dB
Frequency response 20 Hz~15 kHz, +1 dB, -2 dB
Alternate channel selectivity 65 dB
Capture ratio 1.0 dB
Image rejection at 98 MHz 45 dB
IF rejection at 98 MHz 80 dB
Spurious response rejection at 98 MHz 75 dB
AM suppression 50 dB

Technics

Matsushita Services Company
Division of Matsushita Electric
Corporation of America
50 Meadowland Parkway,
Secaucus, New Jersey 07094

Panasonic Sales Company,
Division of Matsushita Electric
of Puerto Rico, Inc.
San Gabriel Industrial Park
65th Infantry Ave. Km.9.5
Carolina, P.R. 00630

Matsushita Electric of Canada
Limited
5770 Ambler Drive, Mississauga,
Ontario, L4W 2T3

Stereo separation	
1 kHz	40 dB
10 kHz	30 dB
Carrier leak	
19 kHz	-35 dB
38 kHz	-50 dB
Antenna terminals	300 ohms (balanced)
	75 ohms (unbalanced)

AM TUNER SECTION

Frequency range	530~1720 kHz
Sensitivity	20 μV, 330 μV/m
Selectivity	55 dB
Image rejection at 1000 kHz	40 dB
IF rejection at 1000 kHz	60 dB

CONTENTS

	Page
SAFETY PRECAUTION	2
ACCESSORIES	2
REAR PANEL TERMINALS AND FUNCTIONS	3
FRONT PANEL CONTROLS AND FUNCTIONS	4~11
DISASSEMBLY INSTRUCTIONS	12~16
PROTECTION CIRCUITRY	17
BEFORE REPAIR AND ADJUSTMENT	17
MEASUREMENTS AND ADJUSTMENTS	17, 18
TERMINAL FUNCTION OF IC'S	19, 20
BLOCK DIAGRAM	21~25

GENERAL

Power consumption	375 W, 480 VA
Power supply	AC 120V, 60Hz
Dimensions (W × H × D)	430 × 134 × 305 mm
	(16-15/16" × 5-9/32" × 12")
Weight	8.5 kg (18.7 lb.)

Notes:

1. Total harmonic distortion is measured by the digital spectrum analyzer.
2. Specifications are subject to change without notice. Weight and dimensions are approximate.

	Page
TERMINAL GUIDE OF IC'S, TRANSISTORS AND DIODES...	26
INTERNAL CONNECTION OF FL	27
SCHEMATIC DIAGRAM	28~44
PRINTED CIRCUIT BOARDS	45~51
WIRING CONNECTION DIAGRAM	52
EXPLODED VIEW	53, 54
REPLACEMENT PARTS LIST	55~59
RESISTORS & CAPACITORS	60~63
PACKING	64

SAFETY PRECAUTION (This "safety precaution" is applied only in U.S.A.)

1. Before servicing, unplug the power cord to prevent an electric shock.
2. When replacing parts, use only manufacturer's recommended components for safety.
3. Check the condition of the power cord. Replace if wear or damage is evident.
4. After servicing, be sure to restore the lead dress, insulation barriers, insulation papers, shields, etc.
5. Before returning the serviced equipment to the customer, be sure to make the following insulation resistance test to prevent the customer from being exposed to a shock hazard.

INSULATION RESISTANCE TEST

1. Unplug the power cord and short the two prongs of the plug with a jumper wire.
2. Turn on the power switch.
3. Measure the resistance value with ohmmeter between the jumpered AC plug and each exposed metal cabinet part, such as screwheads antenna, control shafts, handle brackets, etc. Equipment with antenna terminals should read between 3MΩ and 5.2MΩ to all exposed parts. (Fig. A) Equipment without antenna terminals should read approximately infinity to all exposed parts. (Fig. B)

Note: Some exposed parts may be isolated from the chassis by design. These will read infinity.

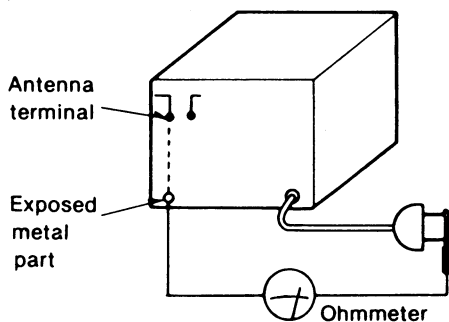

(Fig. A)
Resistance = 3 MΩ—5.2 MΩ

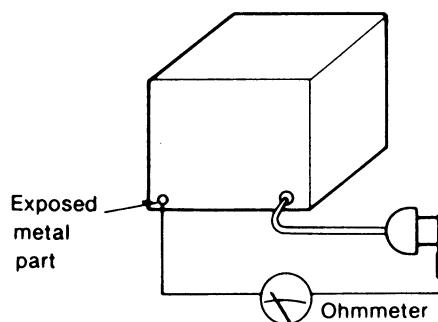

(Fig. B)
Resistance = Approx ∞

4. If the measurement is outside the specified limits, there is a possibility of a shock hazard. The equipment should be repaired and rechecked before it is returned to the customer.

ACCESSORIES

- AC power supply cord (SJA172)..... 1 pc.
- AM loop antenna (SPB1163T) 1 pc.
- Remote control transmitter (RAK-SA501P) 1 pc.
- AM antenna holder (SMA233-1M)..... 1 pc.
- FM indoor antenna (SSA272M)..... 1 pc.
- Screws (XTN3+10AFZ)..... 2 pcs.

REAR PANEL TERMINALS AND FUNCTIONS

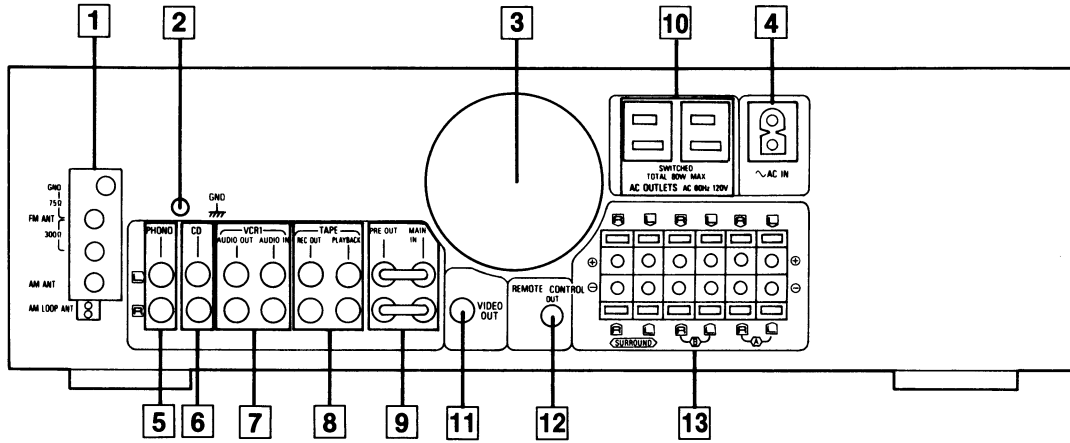

1 Antenna connection terminals

2 "GND" terminal

Connect the turntable's ground wire to this terminal (if applicable).

3 Cooling fan

The cooling fan operates at high output power levels only.

4 AC IN socket (AC IN)

Connect this socket to an AC outlet on the wall using the power supply cord.

5 "PHONO" terminals

Connect a turntable only. Do not connect any other sound source to these terminals.

6 "CD" terminals

Connect a compact disc player or other sound source.

7 "VCR 1" terminals

Connect a video cassette recorder or an audio tape deck, etc. (See the operating instructions of the VCR, etc.)

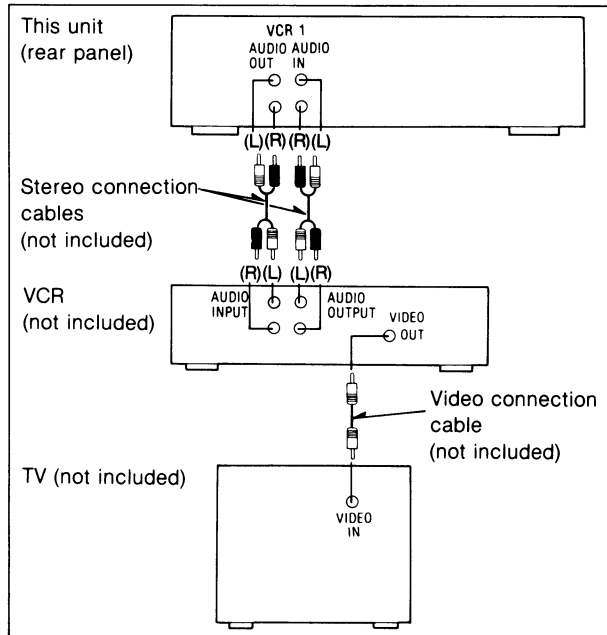

8 "TAPE" terminals

Connect a tape deck or second video cassette recorder.

9 "PRE OUT/MAIN IN" terminals

Do not remove the shorting pins from these terminals unless you plan to use an independent preamplifier or main amplifier. (No sound will be heard if they are removed). To use it in this way, refer to the operating instructions for the additional amplifier or preamplifier that you plan to use.

10 Outlets "SWITCHED"

Power to these outlets is controlled by the power switch of this unit. Audio equipment rated up to 80 W (total for all outlets) can be connected here. For proper remote-control operation, connect the power cords of the tape deck and compact disc player to these outlets as indicated below:

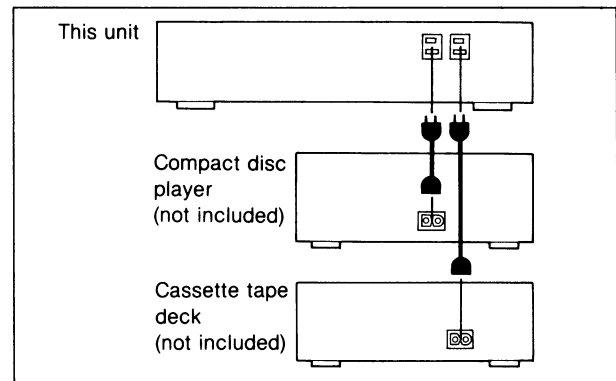

11 "VIDEO OUT" terminal

Connect a video connection cable (not included) to the video input terminal of VCR or TV.

12 Remote-control OUT terminal (REMOTE CONTROL OUT)

This terminal can be used only with Technics components which have the appropriate remote-control terminal. (Consult your dealer for details.)

Proper connection with remote-control connection cables SJP2257T will allow control of some functions from this unit's remote-control transmitter.

Connect to a tape deck and/or compact disc player as shown below.

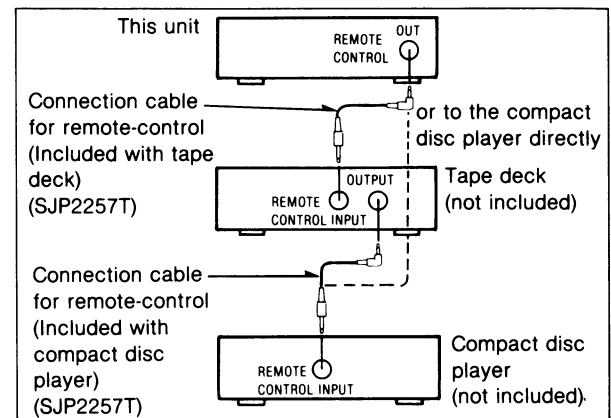

13 Speaker connection terminals

FRONT PANEL CONTROLS AND FUNCTIONS

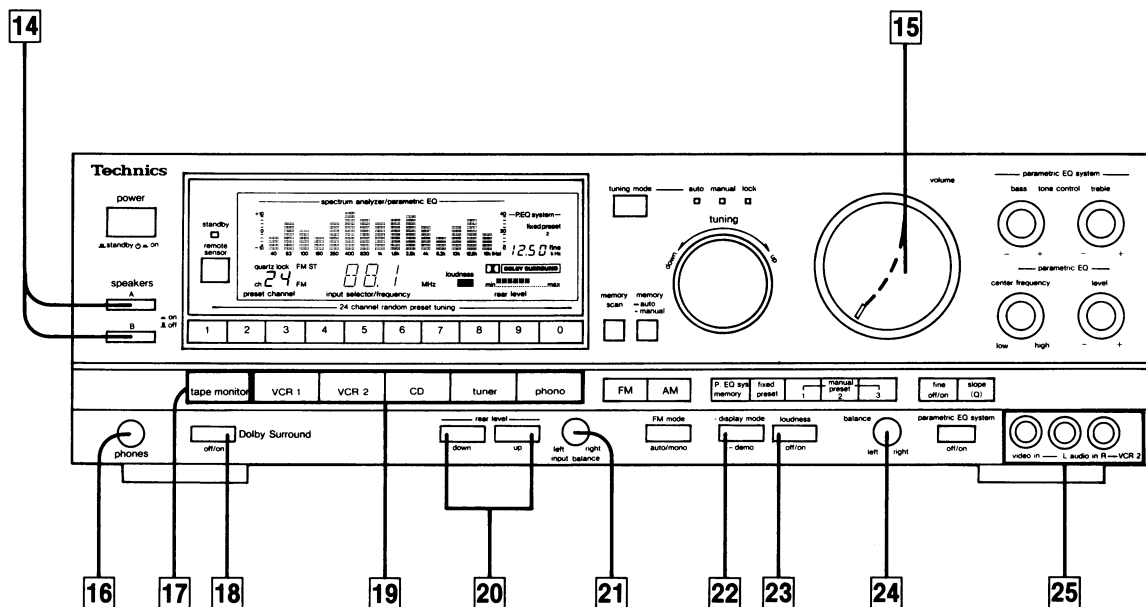

Amplifier section

14 Speaker selectors (speakers)

These selectors are used to select the speaker system(s) (A and/or B).

15 Volume control/indicator (volume)

16 Headphone jack (phones)

17 Tape-monitor switch (tape monitor)

Press this button to listen to a tape or an equipment connected to the "TAPE" terminals.

To listen to some other source, press this button once again (so that the indicator is switched OFF).

18 Dolby surround ON/OFF switch (Dolby Surround)

This switch is used to activate the Dolby surround effect. When this switch is switched OFF, no sound will be heard from the surround speaker systems.

19 Input selector buttons

These buttons are used to select the sound source to be heard, such as a disc, radio broadcasts, etc. The selected sound source is shown on the audio input selector/frequency display.

The "phono" input selector has two functions: when pressed momentarily it selects "phono". when pressed and held for about 3 seconds, it de-activates the muting function.

20 Rear speaker volume control buttons (rear level)

These buttons are used to adjust the volume level of the surround speaker systems.

21 Dolby surround input balance control (input balance)

This control is used to minimize dialogue leakage in the surround channel thereby optimizing the Dolby surround decoding operation.

22 Display mode button (display mode)

This button is used to select either the spectrum analysis level ("Bar-type display", "Dot display" or "Peak hold display") or equalization level display.

If the button is pressed for 3 seconds or more, this unit will start a demonstration mode for the parametric EQ system. (Refer to page 23 for detailed information.)

23 Loudness switch (loudness)

Set to the "on" position (the loudness indicator will illuminate); when listening to music at low volume. Auditory perception of sound in the low frequency range falls off at low volume, but when the switch is in this position, this deficiency is compensated for, so that the full impact of the musical performance can be enjoyed.

24 Balance control (balance)

25 "VCR 2" terminals (VCR 2)

These terminals are used for tape-to-tape recording if a second VCR is connected here.

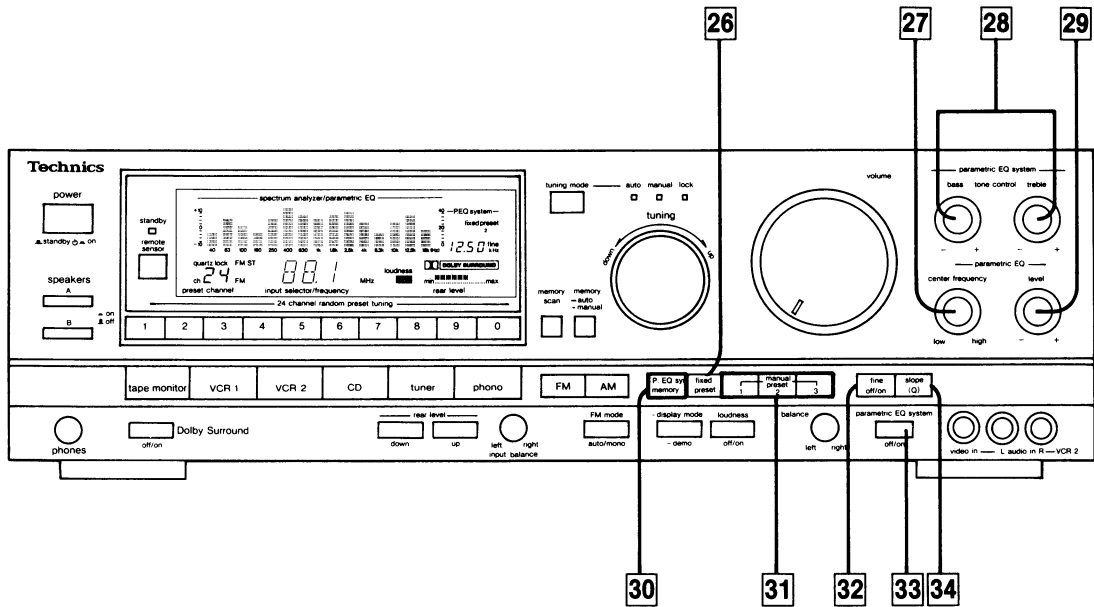

26 Fixed preset button (fixed preset)

This button is used to recall a “fixed preset” curve from the main unit’s memory.

31 Equalization preset buttons (manual preset)

These buttons are used for storing or recalling the curves made by the parametric EQ system.

27 Center frequency control (center frequency)

This control is used to adjust the center frequency of the parametric EQ.

Making sound that matches the source can be enjoyed by combining this control with the level control and tone controls.

32 Fine mode select button (fine off/on)

This button is used to fine-adjust the center frequency of the parametric EQ.

28 Tone controls (bass/treble)

These controls are used to balance the high-frequency and low-frequency sounds of the parametric EQ system.

33 Parametric EQ system ON/OFF button (parametric EQ system)

This button is used to turn the parametric EQ system ON or OFF.

29 Level control (level)

This control is used to adjust the level of the parametric EQ.

34 Slope changeover button [slope (Q)]

This button is used to increase or decrease the slope of the parametric EQ curves.

30 Parametric EQ system memory button (P. EQ system memory)

This button enables the curves to be stored in the parametric EQ system memory.

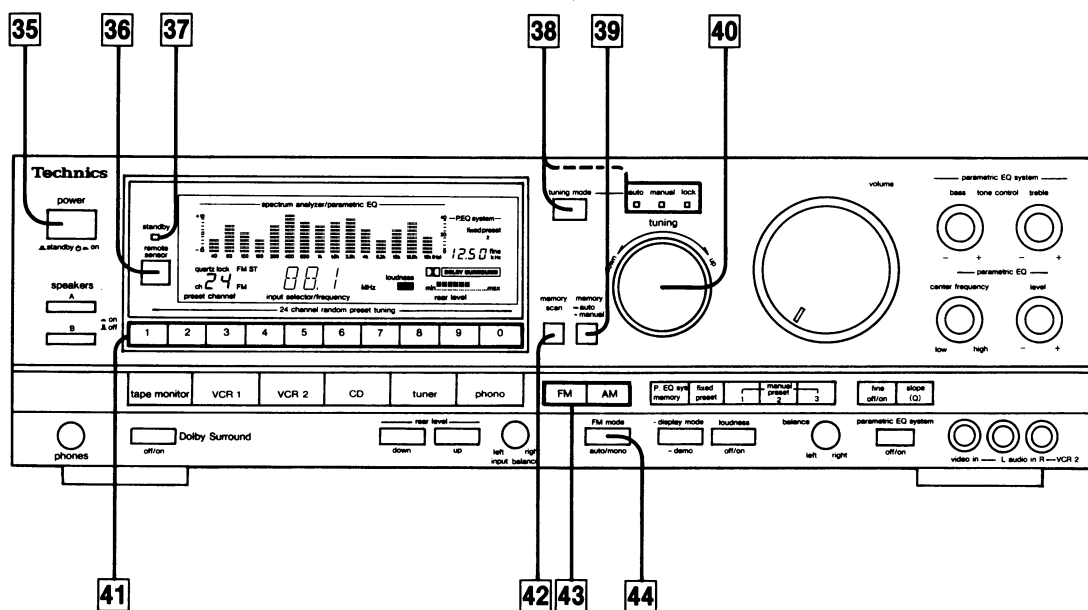

Tuner section

35 Power “standby /on” switch (power/ standby)

If the power was switched OFF from the remote control, to switch the power ON from the unit, set the switch to OFF and then ON again.

Note:

The power can not be controlled from the remote control unless this switch is set to ON.

36 Remote-control signal receptor (remote sensor)

Receives the signals from the remote-control.

37 “standby” indicator (standby)

This indicator illuminates when the power switch of this unit or that of the remote control is switched “OFF”. Its purpose is to alert the user of the constant supply voltage to the internal circuitry even with the power switch OFF.

38 Tuning-mode selector/indicator (tuning mode)

Each time this selector is pressed, the selection changes, in sequence, to “auto”, “manual” and “lock”.

auto:

In this position, broadcast channels are automatically selected when the tuning control is turned to the left or right to start the frequency changing.

manual:

In this position, the tuning control can be used to locate the desired channel manually.

lock:

In this position, the broadcast channel presently being heard is locked in, and other broadcast stations cannot be tuned to, even if the tuning control is turned.

39 Memory button (memory)

This button is used when presetting broadcast station frequencies into memory.

40 Tuning control (tuning)

This control is used to select an FM or AM broadcast. When turning the control to the left, the frequency changes downward. When turning the control to the right, the frequency change upward.

41 Preset-tuning buttons (1–0) (24 channel random preset tuning)

These buttons are used to preset broadcast frequencies into the memory of this unit and to recall the desired preset stations.

42 Memory scan button (memory scan)

This button can be used to locate a desired broadcast station; each broadcast station is selected for about 3 seconds.

43 Band selectors

FM: Press this button to listen to an FM broadcast.

AM: Press this button to listen to an AM broadcast.

44 FM mode selector (FM mode)

This unit automatically switches to the stereo mode when an FM stereo broadcast is received. This selector is used to select the mode (stereo or monaural) of FM broadcast signals.

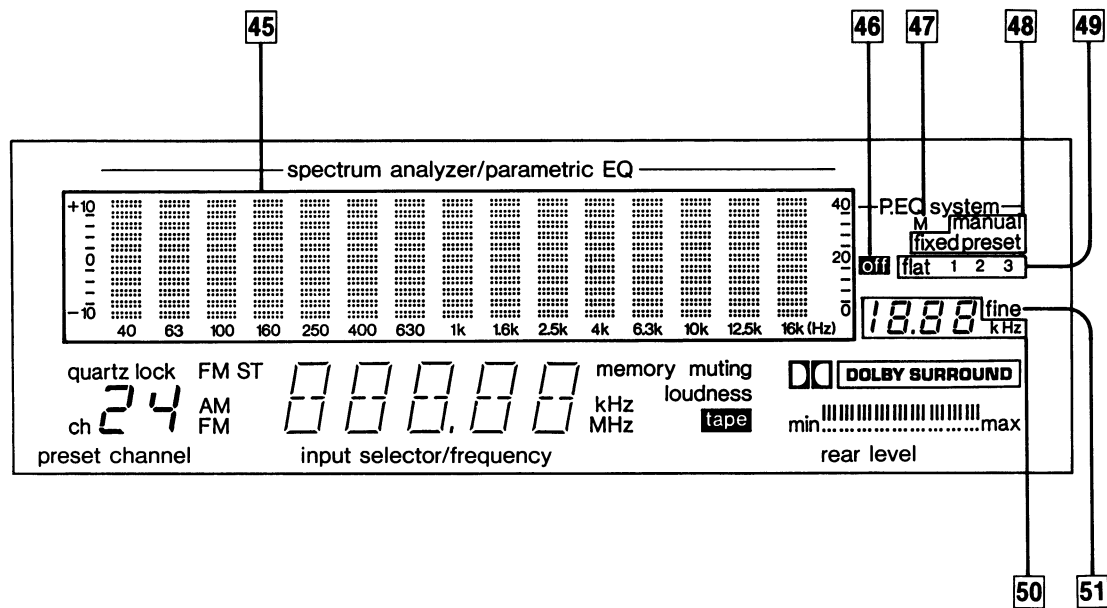

Display section

45 Spectrum analysis/parametric EQ level display (spectrum analyzer/parametric EQ)

This display shows the spectrum analysis level ("Bar-type display", "Dot display" or "Peak hold display") or equalization level.

Note:

When the display is set for spectrum analysis display, if buttons 26, 31, 32, 34 and controls 27, 28, 29 of the amplifier section are pressed, the display will change to the equalization level display but will return to the spectrum analysis display about 5 seconds later.

46 Parametric EQ system off indicator (off)

This indicator illuminates when the parametric EQ system is off.

47 Parametric EQ system memory indicator (M)

This indicator illuminates when the parametric EQ system memory button is selected.

48 Parametric EQ system operation select indicators (manual/fixed)

One of these indicators will illuminate in accordance with the fixed preset button or equalization preset buttons setting.

49 Manual/fixed preset indicators (flat 1 2 3)

It displays the type of curve selected with the equalization preset buttons or fixed preset button.

50 Parametric EQ system center frequency display

It displays the center frequency of the curves arranged by the user with the parametric EQ system or the curves pre-stored in this unit's memory.

51 Fine mode indicator (fine)

This indicator illuminates when the fine mode select button is selected.

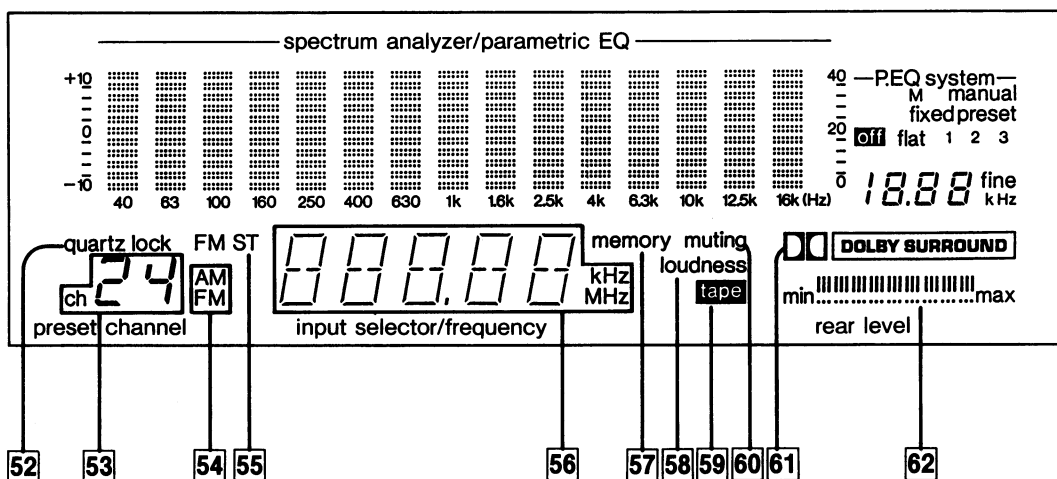
**52 Quartz-lock indicator (quartz lock)**

This indicator illuminates when the unit is tuned precisely to a broadcast station.

53 Channel display

This display shows the channel number selected by one of the preset-tuning buttons.

54 Band indicators (AM/FM)

Indicates the selected band.

55 FM stereo indicator (FM ST)

This indicator automatically illuminates when an FM stereo broadcast is being received.

Note:

It will not illuminate if the FM mode selector is set to the monaural mode.

56 Audio input selector/frequency display (input selector/frequency)

Displays the selected source or broadcast frequency.

57 Memory indicator (memory)

This indicator illuminates when the memory button is pressed.

58 Loudness indicator (loudness)

This indicator will illuminate when the loudness switch is pressed.

59 Tape indicator (tape)

This indicator will illuminate when the tape-monitor switch is pressed.

60 Muting indicator (muting)

This indicator will illuminate when the muting button (on the remote-control transmitter) is pressed.

61 Dolby surround indicator (DOLBY SURROUND)

This indicator illuminates when the Dolby surround ON/OFF switch is set to ON.

62 Rear level indicator

It display the level adjusted by the rear speaker volume control buttons.

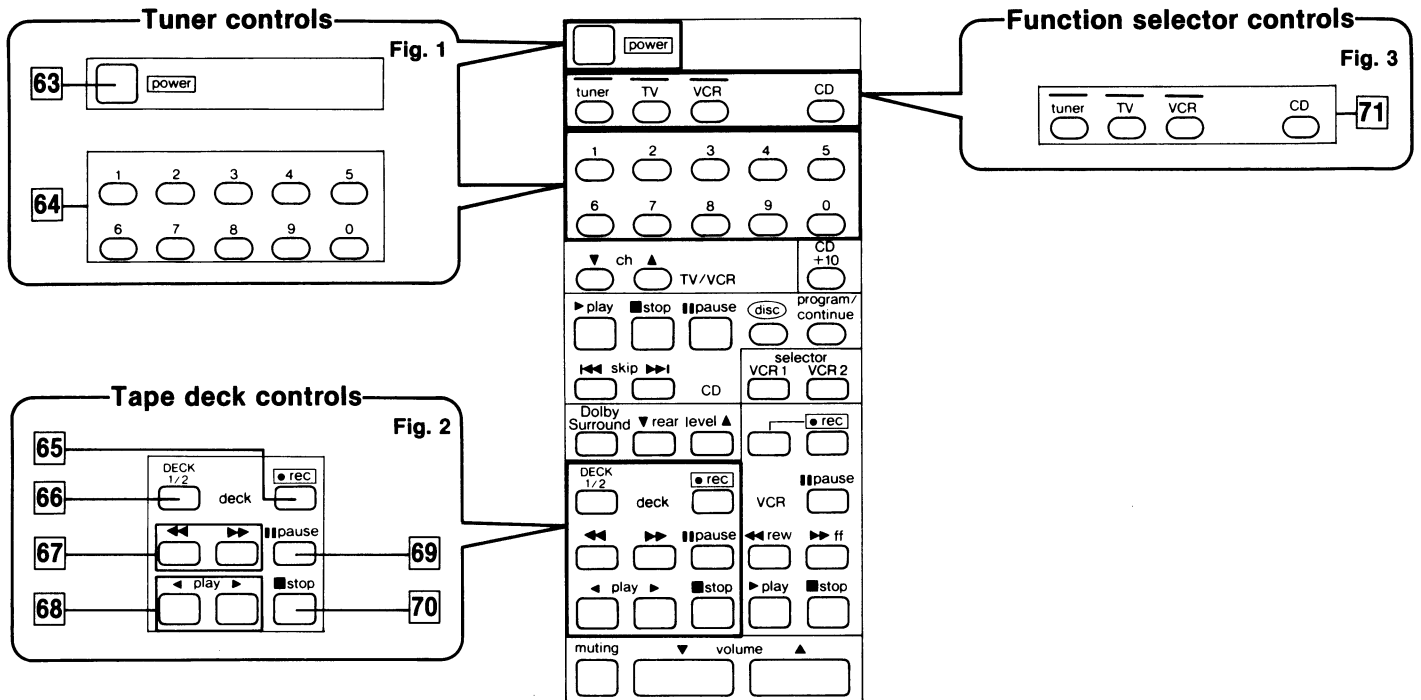

Remote control section

Tuner controls (Fig. 1)

63 Power switch (power)

This power switch is used for controlling the power (ON/OFF) of this unit as well as any Panasonic remote controlled TV and/or VCR.

When switching the power of each unit ON and OFF, be sure to first press the appropriate function selector button on the remote control transmitter.

64 Preset-tuning buttons (1–0)

These buttons are used to tune to broadcast stations that have been preset to the unit's memory.

When these buttons are used, be sure to first press the "tuner" button of the function selector buttons on the remote control transmitter.

Tape deck controls (Fig. 2)

65 Record button (● rec)

Press this button to change to the recording stand-by mode.

66 Deck 1/Deck 2 selector (DECK 1/2)

This button is used to select the deck to be operated by remote control.

67 Fast-forward/rewind buttons (◀◀, ▶▶)

Press this button to advance or rewind the tape while the unit is in the stop mode.

Press this button to select the desired tune while the unit is in the play mode.

(Only applicable to a Technics tape deck with the "music select" functions.)

68 Playback buttons (◀ play ▶)

▶: For the "A"-side of the tape

◀: For the "B"-side of the tape

Press one of these buttons to begin playback or recording, pressing the button corresponding to the side of the tape to be played (or recorded).

Note:

Depending on which Technics tape deck is used in combination with this unit, tape deck B might be the "A"-side playback-only type.

69 Pause button (|| pause)

Press this button to temporarily stop playback or recording. Press the playback button to resume the play or recording.

70 Stop button (■ stop)

To stop tape play or tape recording.

Function selector controls (Fig. 3)

71 Function selector buttons (tuner, TV, VCR, CD)

These buttons are used to change the functions of this remote control.

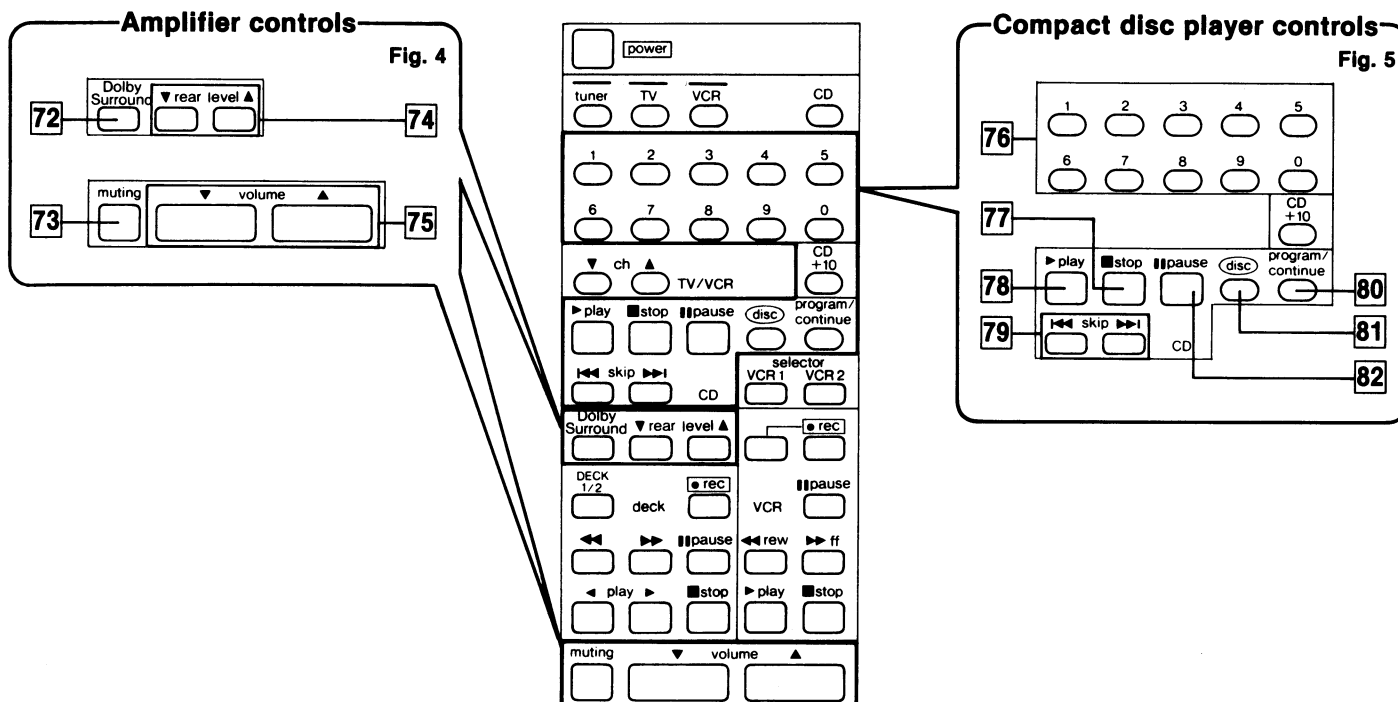

Amplifier controls (Fig. 4)

72 Dolby surround ON/OFF button (Dolby Surround)

This button is used to activate the Dolby surround effect.

73 Muting button (muting)

This button is used to temporarily attenuate ("mute") the volume level.

74 Rear speaker volume control buttons (▼ rear level ▲)

These buttons are used to adjust the volume level of the surround speaker systems.

75 Volume control (▼ volume ▲)

These buttons are used to adjust the volume level.

▼: To reduce the volume level.

▲: To increase the volume level.

Compact disc player controls (Fig. 5)

76 Numeric buttons (1–0, +10)

These buttons are used to select the track or the disc number (only 1–6).

When these buttons are used, be sure to first press the "CD" button of the function selector buttons of the remote control transmitter.

77 Stop button (■ stop)

To stop compact disc play.

78 Play button (▶ play)

To start compact disc play.

79 Skip buttons (|◀◀ skip ▶▶|)

Press one of these buttons briefly to move the pickup (backward or forward) to the beginning of a specific track.

80 Program/continue button (program/continue)

This button is used to select either the sequential play or program play mode.

81 Disc button (disc)

This button is used when selecting the disc.

82 Pause button (|| pause)

To temporarily stop compact disc play.

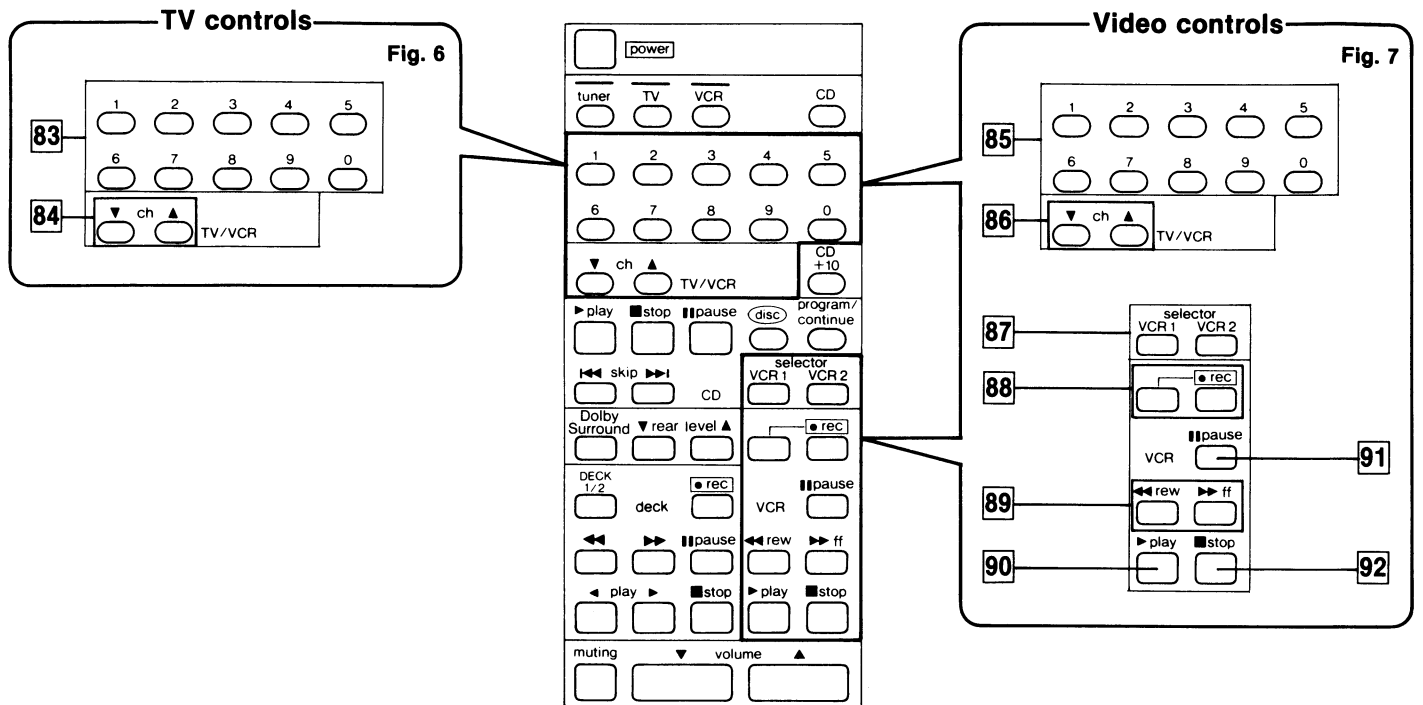

TV controls (Fig. 6)

83 Preset channel buttons (1–0)

These buttons are used to select TV channels.

84 Channel up/down buttons (▼ ch ▲)

These buttons are used to select TV channels.

Video controls (Fig. 7)

85 Preset channel buttons (1–0)

These buttons are used to select video channels.

86 Channel up/down buttons (▼ ch ▲)

These buttons are used to select video channels.

87 Input selector buttons (VCR 1/VCR 2)

These buttons are used to select VCR 1 or VCR 2. The unit's input selector is changed over when the button is pressed.

88 Record buttons (● rec)

These buttons are used to record.

89 Fast-forward/rewind buttons (◀◀ rew, ▶▶ ff)

Press one of these buttons to advance or rewind the tape while the unit is in the stop mode.

90 Playback button (▶ play)

This button is used for video playback.

91 Pause button (⏸ pause)

This button is used to pause during playback or video recording.

92 Stop button (■ stop)

This button is used to stop playback or video recording.

DISASSEMBLY INSTRUCTIONS

"ATTENTION SERVICER"

Some chassis components may have sharp edges. Be careful when disassembling and servicing.

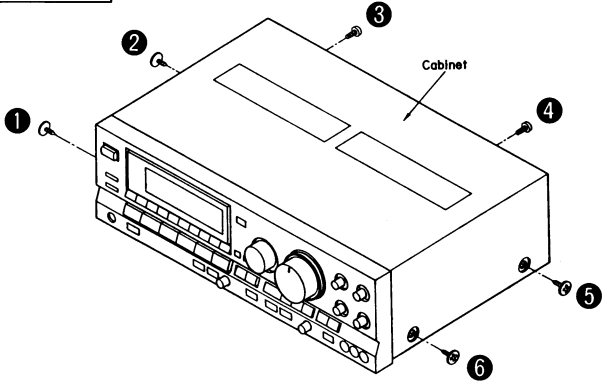
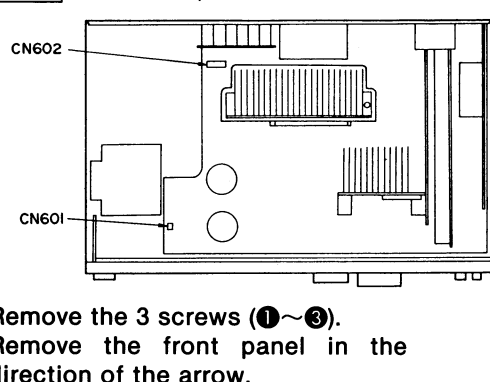
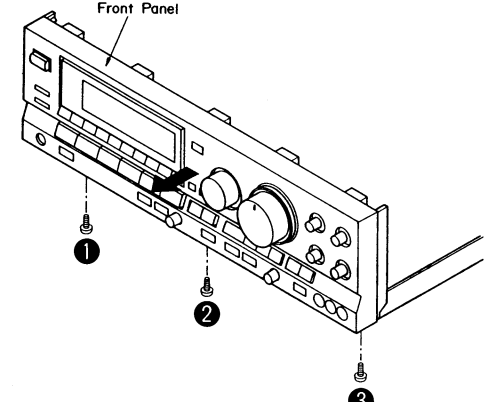
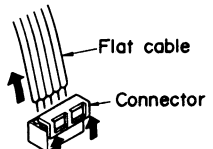
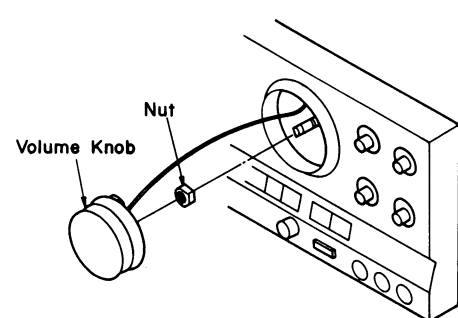
Ref. No. 1	Removal of the cabinet	Ref. No. 2	Removal of the front panel
Procedure 1		Procedure 1→2	1. Remove the 2 flat cables (CN601, CN602).
 <p>• Remove the 6 screws (①~⑥).</p>		 <p>2. Remove the 3 screws (①~③). 3. Remove the front panel in the direction of the arrow.</p>	
Ref. No. 3	Removal of the power switch P.C.B.	 <p>How to remove the flat cable</p> <ol style="list-style-type: none"> 1. Lift the connector. 2. Pull out the flat cable. 	
Procedure 1→2→3			
Ref. No. 4	Removal of the volume P.C.B.	 <ol style="list-style-type: none"> 3. Remove the 1 screw (①). 4. Remove the 1 connector (CN705A). 5. Remove the volume P.C.B. in the direction of the arrow. 	
Procedure 1→2→4			
<ol style="list-style-type: none"> 1. Pull out the volume knob. 2. Remove the nut. 			

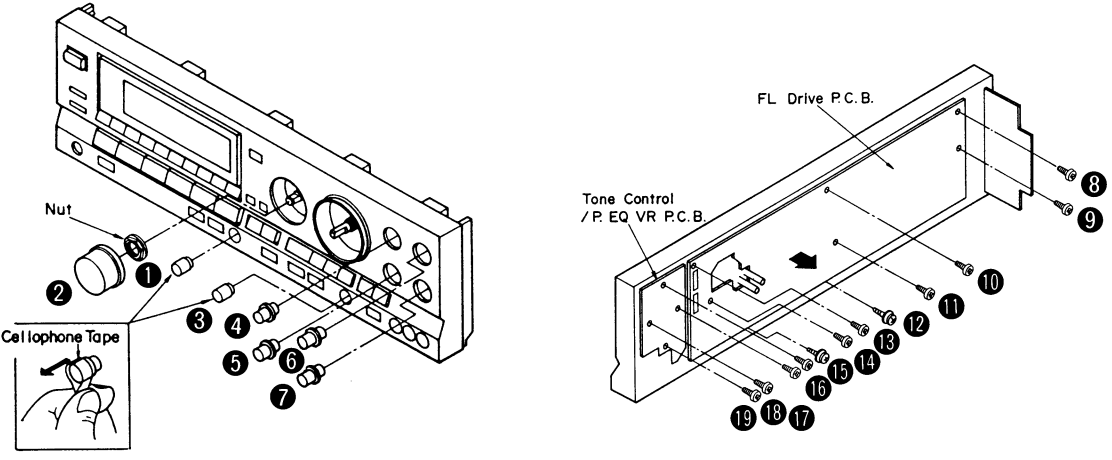
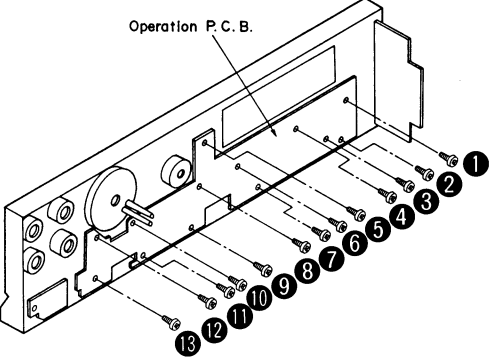
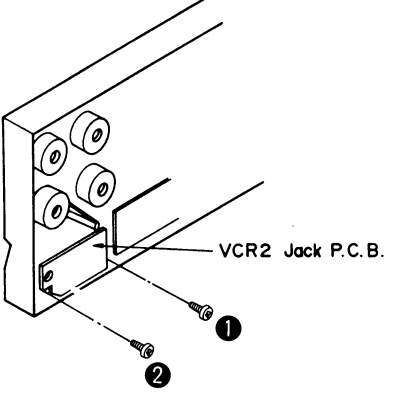
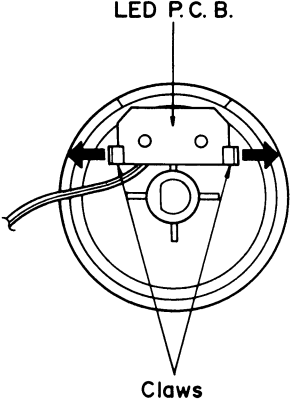
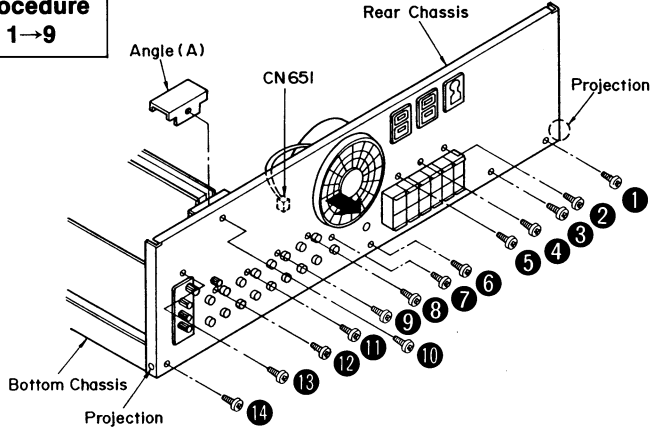
Ref. No. 5	Removal of the FL drive P.C.B. and tone control/P.EQ VR P.C.B.	 <ol style="list-style-type: none"> 1. Pull out the 7 knobs (1~7) 2. Remove the nut. 3. Remove the 12 screws (8~19). 	
Ref. No. 6	Removal of the operation P.C.B.	Ref. No. 7	Removal of the VCR2 jack P.C.B.
Procedure 1→2→4→5 →6	 <ul style="list-style-type: none"> • Remove the 13 screws (1~13). 	Procedure 1→2→4→5 →7	 <ul style="list-style-type: none"> • Remove the 2 screws (1, 2).
Ref. No. 8	Removal of the LED P.C.B.	Ref. No. 9	Removal of the rear chassis
Procedure 1→2→4→8	 <ul style="list-style-type: none"> • Release the 2 claws. 	Procedure 1→9	 <ol style="list-style-type: none"> 1. Remove the 1 connector (CN651). 2. Remove the 14 screws (1~14). 3. Remove the angle (A). 4. Remove the rear panel from the projection of the bottom chassis.

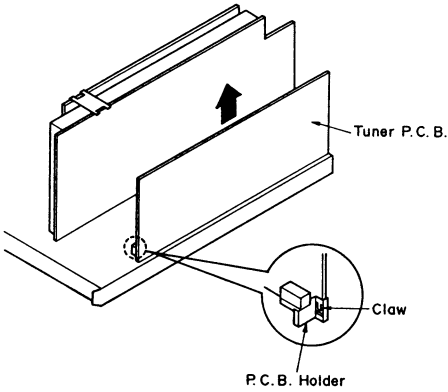
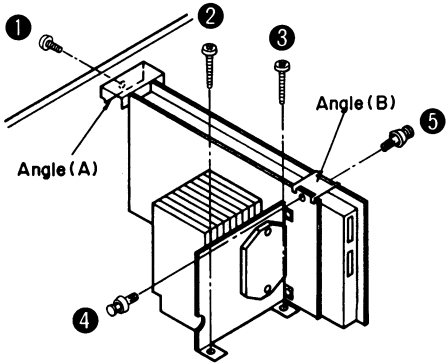
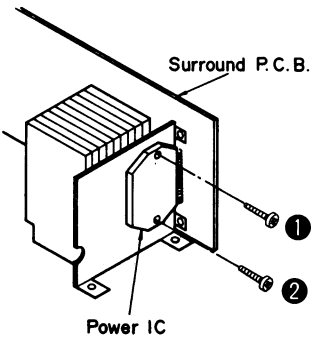
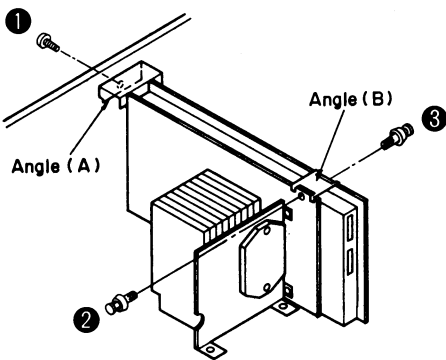
Ref. No. 10	Removal of the tuner P.C.B.	Ref. No. 11	Removal of the surround P.C.B.
Procedure 1→2→9→10		Procedure 1→2→11	
	<ol style="list-style-type: none"> 1. Release the 1 claw. 2. Remove the tuner P.C.B. in the direction of the arrow. 		<ol style="list-style-type: none"> 1. Remove the 3 screws (①~③). 2. Remove the angle (A). 3. Remove the 2 latch (④, ⑤). 4. Remove the angle (B).
Ref. No. 12	Removal of the Power IC		
Procedure 1→2→11 →12	<ol style="list-style-type: none"> 1. Unsolder the power IC. 2. Remove the 2 screws (①, ②). <ul style="list-style-type: none"> • When mounting the power IC, apply silicon thermal compound (SZZ0L15 or equivalent) to the rear of the power IC. 		<ol style="list-style-type: none"> 5. Remove the 1 flat cable (CN703). 6. Remove the surround P.C.B. in the direction of the arrow.
Ref. No. 13	Removal of the parametric EQ P.C.B.		
Procedure 1→2→13	<ol style="list-style-type: none"> 1. Remove the 1 screw (①). 2. Remove the angle (A). 3. Remove the 2 latch (②, ③). 4. Remove the angle (B). 		<ol style="list-style-type: none"> 5. Release the 1 claw. 6. Remove the parametric EQ P.C.B. in the direction of the arrow.

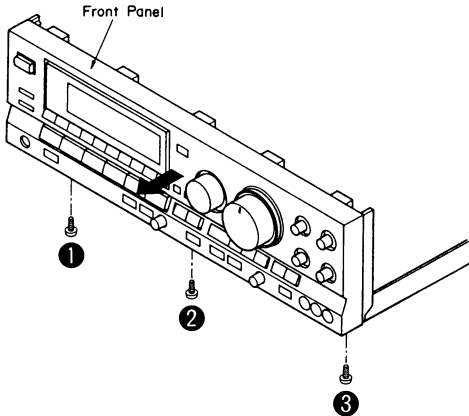
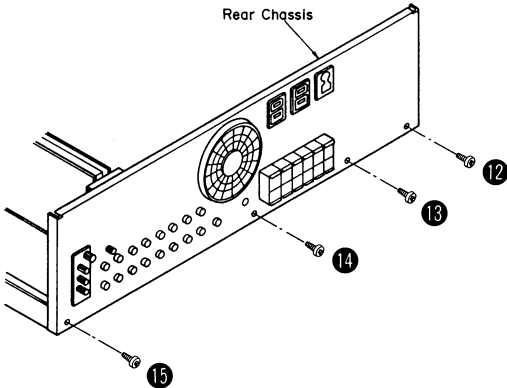
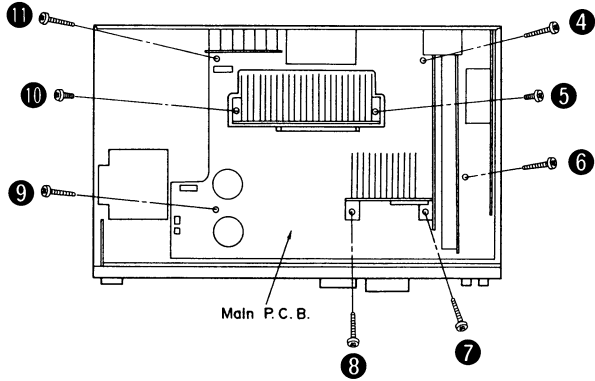
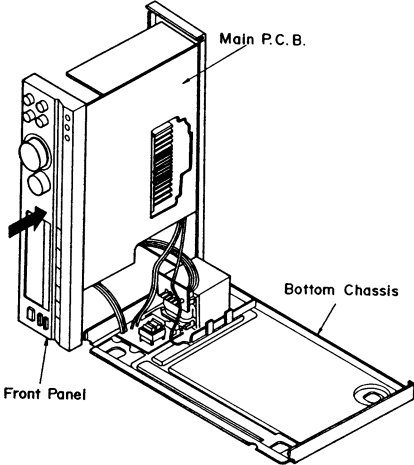
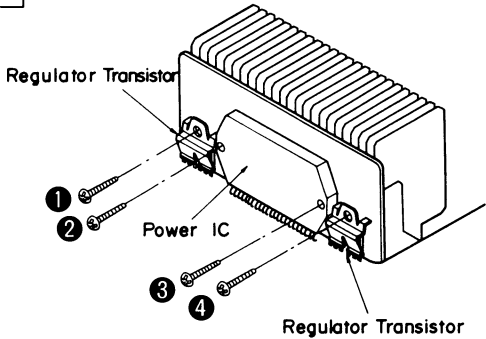
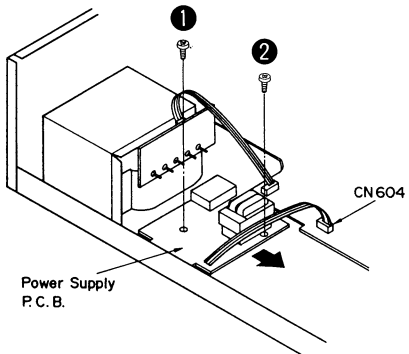
Ref. No. 14	How to check the main P.C.B.		
Procedure 1→14			
 <ol style="list-style-type: none"> 1. Remove the 3 screws (①~③). 2. Remove the front panel in the direction of the arrow. 	 <ol style="list-style-type: none"> 4. Remove the 4 screws (⑫~⑮). 	 <ol style="list-style-type: none"> 3. Remove the 8 screws (④~⑪).  <ol style="list-style-type: none"> 5. Remove the bottom chassis. 6. Reinstall the front panel to the main P.C.B. 	
Ref. No. 15	Removal of the power IC and regulator transistor	Ref. No. 16	Removal of the power supply P.C.B.
Procedure 1→14→15		Procedure 1→2→16	
 <ol style="list-style-type: none"> 1. Unsolder the power IC or regulator transistor. 2. Remove the 4 screws (①~④). <ul style="list-style-type: none"> • When mounting the power IC or regulator transistor. Apply silicone compound (SZZ0L15) to the rear side of power IC or regulator transistor. 			 <ol style="list-style-type: none"> 1. Remove the 1 flat cable (CN604). 2. Remove the 2 screws (①, ②). 3. Remove the power supply P.C.B. in the direction of the arrow.

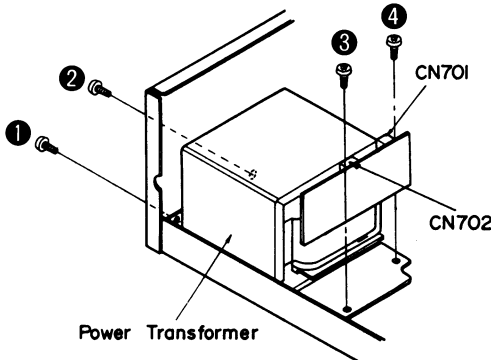
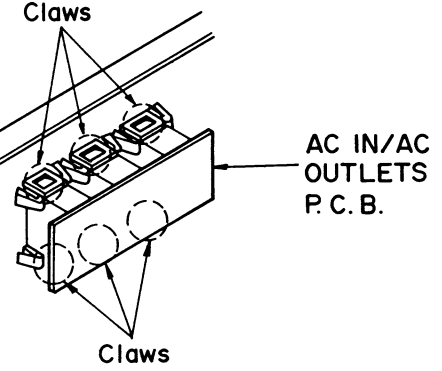
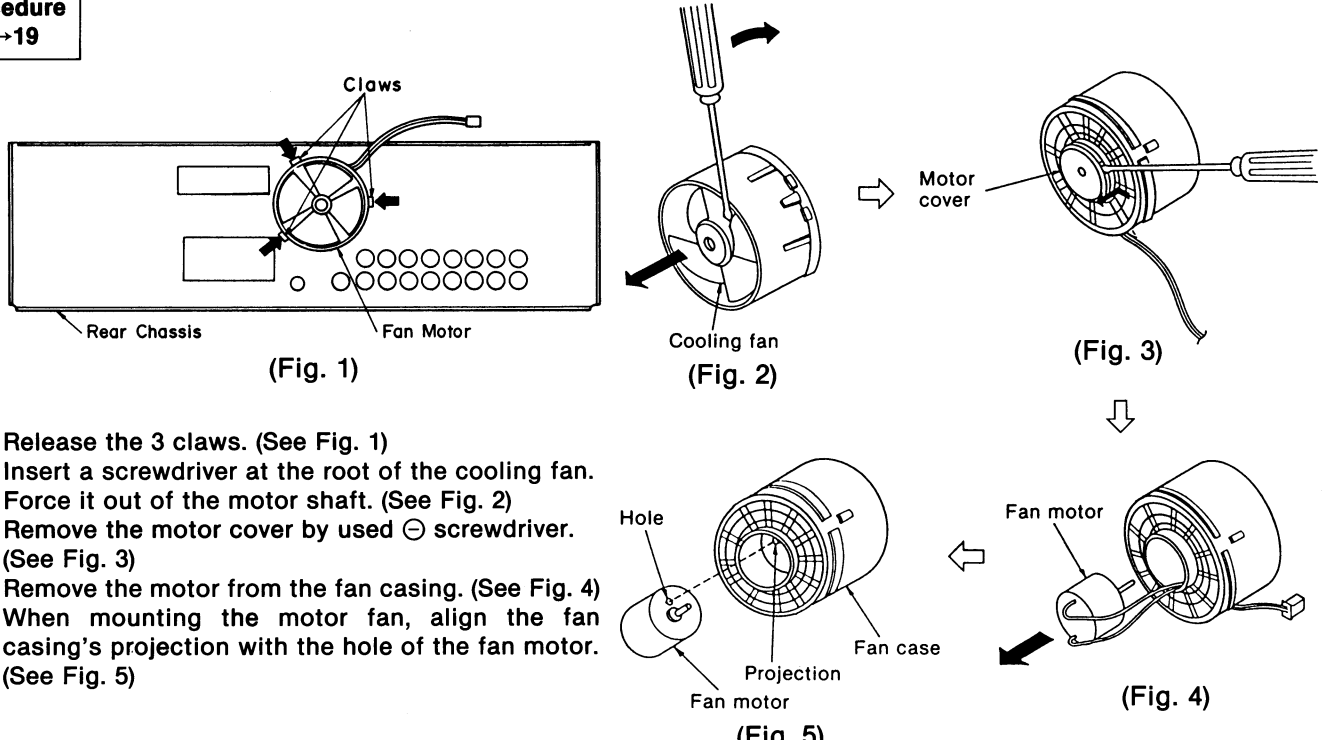
Ref. No. 17	Removal of the power transformer	Ref. No. 18	Removal of the AC IN/ AC OUTLETS P.C.B.
Procedure 1→2→16 →17		Procedure 1→18	
	 <p>1. Remove the 2 flat cables (CN701, CN702). 2. Remove the 4 screws (①~④).</p>		 <p>• Release the 6 claws.</p>
Ref. No. 19	Removal of the fan motor		
Procedure 1→19			
	 <p>1. Release the 3 claws. (See Fig. 1) 2. Insert a screwdriver at the root of the cooling fan. Force it out of the motor shaft. (See Fig. 2) 3. Remove the motor cover by used ⊖ screwdriver. (See Fig. 3) 4. Remove the motor from the fan casing. (See Fig. 4) 5. When mounting the motor fan, align the fan casing's projection with the hole of the fan motor. (See Fig. 5)</p>		

PROTECTION CIRCUITRY

The protection circuitry may have operated if either of the following conditions is noticed:

- No sound is heard when the power is turned on.
- Sound stops during a performance.

The function of this circuitry is to prevent circuitry damage if, for example, the positive and negative speaker connection wires are "shorted", or if speaker systems with an impedance less than the indicated rated impedance of the amplifier are used.

If this occurs, follow the procedure outlines below:

1. Turn off the power.
2. Determine the cause of the problem and correct it.
3. Turn on the power once again after one minute.

Note:

When the protection circuitry functions, the unit will not operate unless the power is first turned off and then on again.

BEFORE REPAIR AND ADJUSTMENT

Disconnect AC power, Discharge both Power Supply Capacitors C701 and C702 through a 10 Ω , 5W resistor to ground.

DO NOT SHORT-CIRCUIT DIRECTLY (with a screwdriver blade, for instance), as this may distroy solid state devices.

After repairs are completed, restore power gradually using a variac, to avoid overcurrent.

Current consumption at 120V, 60Hz in NO SIGNAL mode should be 500~900mA.

MEASUREMENTS AND ADJUSTMENTS

Note: For Z202 (AM-IFT), and Z201 (AM ANT and OSC coil), they are supplied as adjusted parts. So, do not turn the cores of the parts. It is not necessary to adjust the AM circuit.

ADJUSTMENT POINTS

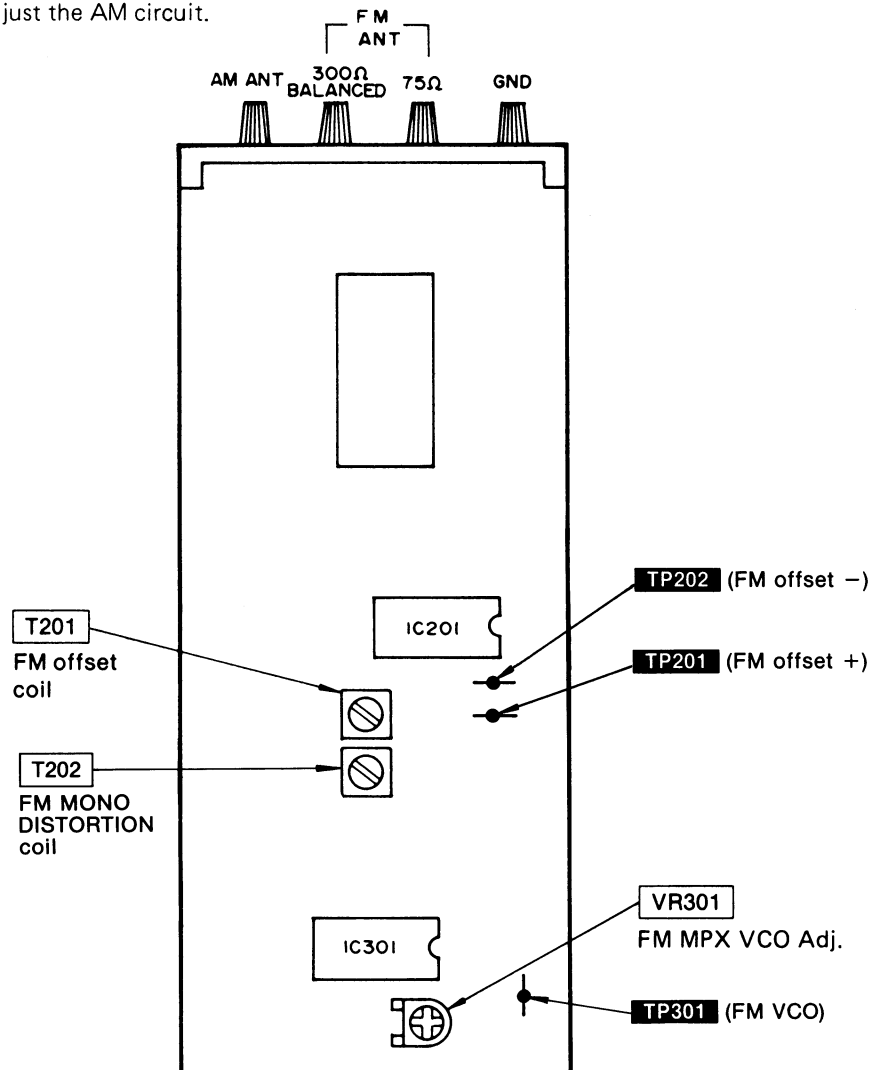

• FM ADJUSTMENT

Control positions and equipment used

- FM signal generator (FM-SG).
- Distortion analyser
- Oscilloscope
- DC electronic voltmeter (EVM)
- Frequency counter
- Choke coil (100 μ H)
- Resistor (100k Ω)

FM MONO DISTORTION ADJUSTMENT

1. Test equipment connection is shown in figure.
2. Set the unit to "FM" position.
3. Set the radio frequency display and signal generator to 100.10 MHz.
4. Adjust T201 core so that voltage measured in signal mode is 0mV (0 ± 20 mV) in 300mV range.
5. Repeat step 4 a few times.
6. Make sure that the distortion factors of Lch and Rch are nearly the same with each other to minimum.

Note:

The adjusting screwdriver used should be made of resin.

FM SIGNAL GENERATOR CONDITION

Modulation100%
 Modulation frequency.....1 kHz
 (MONO)
 Output level.....66 dB

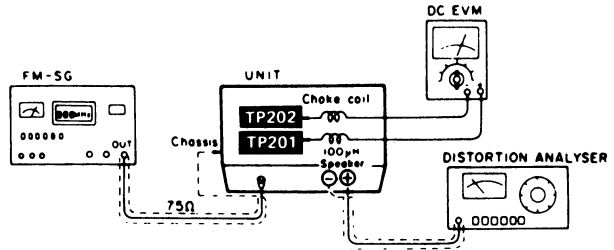

FM MPX VCO ADJUSTMENT

1. Test equipment connection is shown in figure.
2. Set the unit to "FM auto" position.
3. Place the radio frequency display and signal generator setting to 100.10 MHz.
4. Adjust VR301 for 19.00 ± 0.03 kHz on frequency counter reading.

FM SIGNAL GENERATOR CONDITION

Modulation0%
 (non-modulation)
 Output level.....66 dB

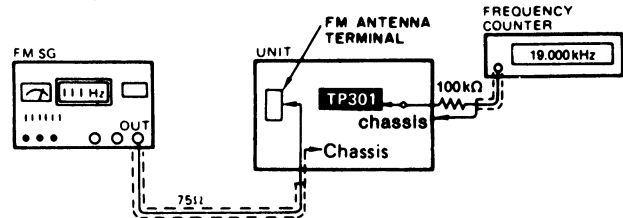

★ USING ALTERNATE SYSTEM

1. Apply stereo signal from generator or receive the stereo broadcast.
2. Adjust VR301 until stereo indicator lights up. Cement arm of VR301 as shown in figure.

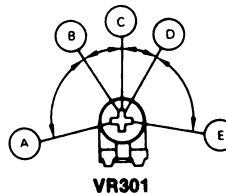

- (A) - (B) (D) - (E) : Stereo OFF position
 (B) - (D) : Stereo ON position
 (indicator lighting)
 (C) : Adjust point of pilot circuit

■ TERMINAL FUNCTION OF IC'S

• IC351 (M37422M6201F): Microcomputer

Pin No.	Mark	I/O Division	Function
1	Vss	—	GND terminal
2 3 4	1B 2A 2B	I	The high frequency (treble) and low frequency (bass) control terminal of the parametric EQ system
5 6	3A 3B	I	The center frequency control terminal of the parametric EQ system
7 8	4A 4B	I	The level control terminal of the parametric EQ system
9	DT1	O	Serial data signal
10	NC	—	(Connected to power supply)
11	INH	O	Inhibit signal of the IC "BCD/DECIMAL DECORDER"
12 14	STA STC	O	Strobe signal of the IC for "BCD/DECIMAL DECORDER" and "FREQUENCY SELECTOR"
15	BPF/FLAT	I	Spectrum analyzer control signal
16	ST1	I	Strobe signal of the IC for "ATTENUATOR/VOLUME CONTROL"
17 18	DIG A DIG B	O	Digit signal of FL display and key scan signal
19	HOLD	I	Power failure detection terminal
20	REMOTE	I	Remote control signal
21	CNVss	—	GND terminal
22	RESET	I	Reset signal
23	NC	—	Not connected
24 25	X IN X OUT	I O	Crystal oscillator terminal
26	NC	—	
27	XC IN	—	Not used, connected to GND

Pin No.	Mark	I/O Division	Function
28	XC OUT	—	Not used, open
29	Vss	—	GND terminal
30	φ	—	Not connected
31 34	K3 K0	I	Key return signal
35	Vp	I	
36	MT	O	Muting control signal
37	DTO/SUR.	O	Clock signal of the IC for "ATTENUATOR/VOLUME CONTROL"
38 39	DIG D DIG C	O	Digit signal of FL display and key scan signal
40 45	S22 S17	O	
46	NC	—	Not connected
47 62	S16 S1	O	Segment signal terminal of FL display
63 64	VCC	I	
65	Vss	—	GND terminal
66	EQ SW	O	EQ selector control signal
67	EQ 10	O	EQ selector control signal
68	FR Q1	O	Frequency control signal
69	FR Q2	O	Frequency control signal (Not used, open)
70	FR Q3	O	Frequency control signal (Not used, open)
71	1A	I	The low frequency (bass) control terminal of the parametric EQ system
72	NC	—	Not connected

• IC901 (LC6554H4399): Microcomputer

Pin No.	Mark	I/O Division	Function	Pin No.	Mark	I/O Division	Function
1	S13	O	Segment signal output	33	ST	O	Level shift control output
2 ┌ 3 └	PA0 ┌ └ PA3	I	Key return signal input	34	L	—	Not used, connected to GND
5				35	V		
6 ┌ 7 └	PB0 ┌ └ PB2	I	Key return signal input	36	TUNING 0	O	LED drive control signal for rotary tuning
8				37	TUNING 1		
9	STAND BY	I	Power supply terminal	38	LOUDNESS	O	Loudness ON/OFF signal output
10	OFF	I	Power ON/OFF det. terminal	39	R	O	Volume motor drive output
11	STEREO	I	Stereo signal det. terminal	40	F		
12	SD	I	Received signal det. terminal	41	A	O	Rotary tuning control signal output
13	DP	I/O	Cassette deck control terminal	42	B		
14	RELAY	O	Relay control output	43	Vp	I	Power supply terminal (negative voltage)
15	DECK	I	Cassette deck control terminal (Not used, connected to GND)	44	S1		
16	OPT1 (IN)	—	Not used, connected to GND				
17	OPT1 (OUT)						
18	MONO	O	FM AUTO/MONO select signal output	55	S12	O	Segment signal output
19	RFM	O	Muting control output for tuner circuit				
20	AT	O	Muting control output for amplifier circuit	56	VDD	I	Power supply terminal (positive voltage)
21	AFM	O	Muting control output for amplifier circuit				
22	TEST	—	Not used, connected to GND	57	D1	O	Digit signal and key scan signal output
23	Vss	—	Ground terminal				
24	OSC1	I	Oscillator terminal	64	D8		
25	OSC2	O					
26	RES	I	Reset signal input				
27	DATA (PF0)	O	Serial data output				
28	CL (PF1)	O	Clock signal terminal for serial data				
29	CE (PF2)	I/O	Chip enable terminal				
30	INT	I	Remote control input				
31	L	—	Not used, connected to GND				
32	L	—	Not used, connected to GND				

TERMINAL GUIDE OF IC'S, TRANSISTORS AND DIODES

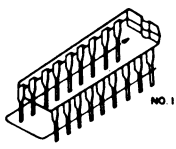
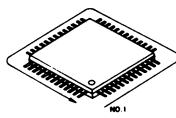
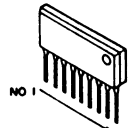
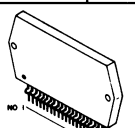
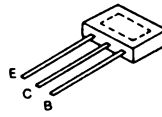
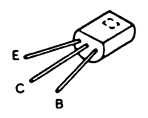
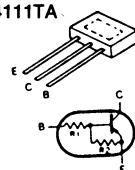
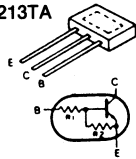
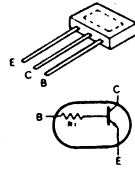
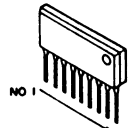
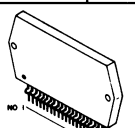
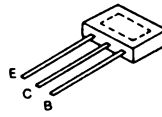
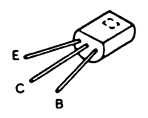
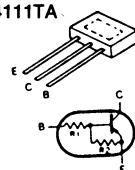
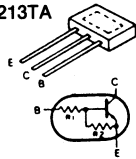
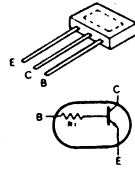
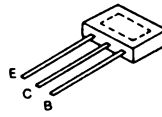
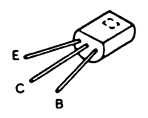
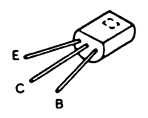
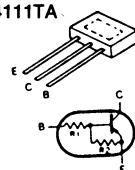
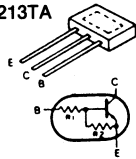
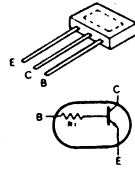
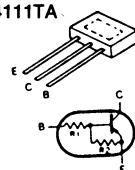
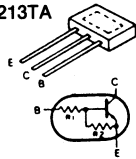
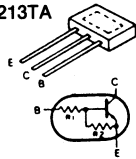
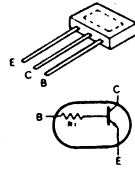
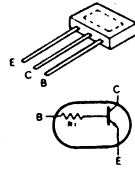
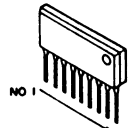
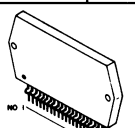
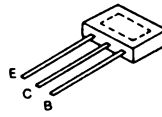
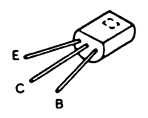
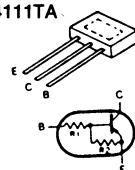
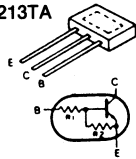
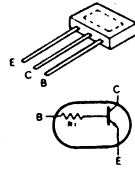
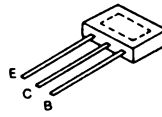
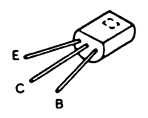
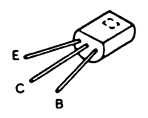
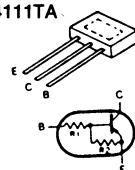
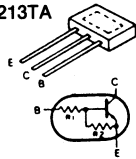
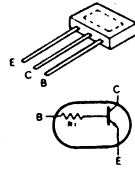
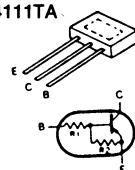
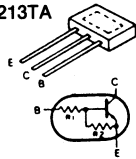
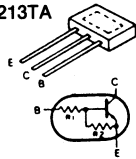
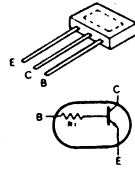
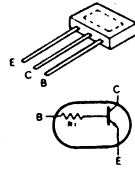
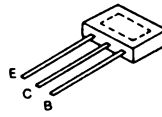
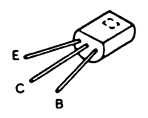
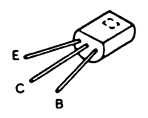
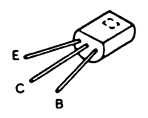
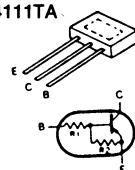
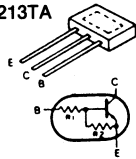
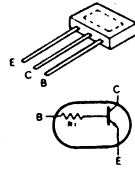
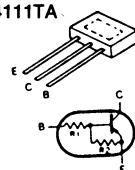
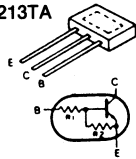
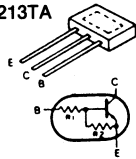
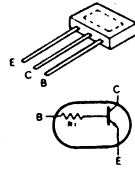
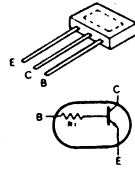
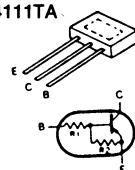
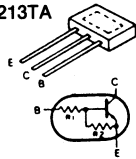
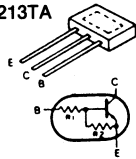
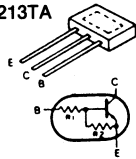
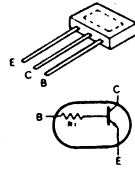
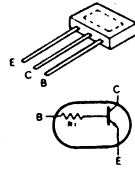
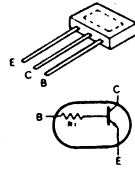
	<table border="1"> <tr><td>LC6554H4399</td><td>64 Pin</td></tr> <tr><td>M37422M6201F</td><td>72 Pin</td></tr> </table> 	LC6554H4399	64 Pin	M37422M6201F	72 Pin																																																																																					
LC6554H4399	64 Pin																																																																																									
M37422M6201F	72 Pin																																																																																									
<table border="1"> <tr><td>M5238P</td><td rowspan="3">8 Pin</td></tr> <tr><td>AN6558F</td></tr> <tr><td>AN6552F</td></tr> <tr><td>M5218P</td></tr> <tr><td>AN6554F</td><td>14 Pin</td></tr> <tr> <td> <table border="1"> <tr><td>LM7001</td><td rowspan="8">16 Pin</td></tr> <tr><td>AN7470</td></tr> <tr><td>TC74HC42AP</td></tr> <tr><td>TC4051BP</td></tr> <tr><td>MN4028B</td></tr> <tr><td>XR-1091DCP</td></tr> <tr><td>SVITA7629P</td></tr> <tr><td>TC9214P</td></tr> <tr><td>AN7273A</td><td>18 Pin</td></tr> <tr><td>TC9212P</td><td>20 Pin</td></tr> <tr><td>M50198P</td><td>24 Pin</td></tr> <tr><td>TC9163N</td><td rowspan="2">28 Pin</td></tr> <tr><td>LC7522</td></tr> </table>  </td> <td> <table border="1"> <tr><td>BA6218</td><td>9 Pin</td></tr> <tr><td>M5241L</td><td>10 Pin</td></tr> </table>  </td> </tr> <tr> <td> <table border="1"> <tr><td>2SA933SQRSTA</td><td rowspan="7">  </td><td> <table border="1"> <tr><td>2SA992EFTA</td><td rowspan="7">  </td></tr> <tr><td>2SC2785FETA</td></tr> <tr><td>2SC2787LTA</td></tr> <tr><td>2SD1450QRSTA</td></tr> <tr><td>2SC3327ABTP</td></tr> <tr><td>2SC3311AQSTA</td></tr> <tr><td>2SA1309AQSTA</td></tr> </table> </td></tr> <tr> <td>2SJ40CDTA</td><td> <table border="1"> <tr><td>UN4113TA</td><td rowspan="2">  </td><td> <table border="1"> <tr><td>UN4211TA</td><td rowspan="3">  </td></tr> <tr><td>UN4111TA</td></tr> <tr><td>UN4214TA</td></tr> <tr><td>UN4213TA</td></tr> </table> </td></tr> <tr> <td>2SB1187DEF</td><td> <table border="1"> <tr><td>UN4215TA</td><td rowspan="2">  </td><td> <table border="1"> <tr><td>2SB1240PRTV6</td><td rowspan="2">  </td></tr> <tr><td>2SD1761DEF</td></tr> </table> </td></tr> <tr> <td> <table border="1"> <tr><td>MA165TA</td><td rowspan="7">  </td><td> <table border="1"> <tr><td>LN846RP-LS</td><td rowspan="7">  </td></tr> <tr><td>MA700ATA</td></tr> <tr><td>MA29WATA</td></tr> <tr><td>SVDS5688GT3</td></tr> <tr><td>1SS291TA</td></tr> <tr><td>P300DLF</td></tr> <tr><td>GP15GLF</td></tr> </table> </td></tr> <tr> <td> <table border="1"> <tr><td>MA4062MTA</td><td>MA4056MTA</td><td rowspan="7">  </td></tr> <tr><td>MA4068MTA</td><td>MA4030MTA</td></tr> <tr><td>MA4110MTA</td><td>MA4075HTA</td></tr> <tr><td>MA4360MTA</td><td>MA4043MTA</td></tr> <tr><td>MA4160LTA</td><td>MA4082MTA</td></tr> <tr><td>MA4120MTA</td><td></td></tr> <tr><td></td><td></td></tr> </table> </td> <td>UN4115TA</td> </tr> </table> </td></tr></table></td></tr></table></td></tr></table></td></tr></table>	M5238P	8 Pin	AN6558F	AN6552F	M5218P	AN6554F	14 Pin	<table border="1"> <tr><td>LM7001</td><td rowspan="8">16 Pin</td></tr> <tr><td>AN7470</td></tr> <tr><td>TC74HC42AP</td></tr> <tr><td>TC4051BP</td></tr> <tr><td>MN4028B</td></tr> <tr><td>XR-1091DCP</td></tr> <tr><td>SVITA7629P</td></tr> <tr><td>TC9214P</td></tr> <tr><td>AN7273A</td><td>18 Pin</td></tr> <tr><td>TC9212P</td><td>20 Pin</td></tr> <tr><td>M50198P</td><td>24 Pin</td></tr> <tr><td>TC9163N</td><td rowspan="2">28 Pin</td></tr> <tr><td>LC7522</td></tr> </table> 	LM7001	16 Pin	AN7470	TC74HC42AP	TC4051BP	MN4028B	XR-1091DCP	SVITA7629P	TC9214P	AN7273A	18 Pin	TC9212P	20 Pin	M50198P	24 Pin	TC9163N	28 Pin	LC7522	<table border="1"> <tr><td>BA6218</td><td>9 Pin</td></tr> <tr><td>M5241L</td><td>10 Pin</td></tr> </table> 	BA6218	9 Pin	M5241L	10 Pin	<table border="1"> <tr><td>2SA933SQRSTA</td><td rowspan="7">  </td><td> <table border="1"> <tr><td>2SA992EFTA</td><td rowspan="7">  </td></tr> <tr><td>2SC2785FETA</td></tr> <tr><td>2SC2787LTA</td></tr> <tr><td>2SD1450QRSTA</td></tr> <tr><td>2SC3327ABTP</td></tr> <tr><td>2SC3311AQSTA</td></tr> <tr><td>2SA1309AQSTA</td></tr> </table> </td></tr> <tr> <td>2SJ40CDTA</td><td> <table border="1"> <tr><td>UN4113TA</td><td rowspan="2">  </td><td> <table border="1"> <tr><td>UN4211TA</td><td rowspan="3">  </td></tr> <tr><td>UN4111TA</td></tr> <tr><td>UN4214TA</td></tr> <tr><td>UN4213TA</td></tr> </table> </td></tr> <tr> <td>2SB1187DEF</td><td> <table border="1"> <tr><td>UN4215TA</td><td rowspan="2">  </td><td> <table border="1"> <tr><td>2SB1240PRTV6</td><td rowspan="2">  </td></tr> <tr><td>2SD1761DEF</td></tr> </table> </td></tr> <tr> <td> <table border="1"> <tr><td>MA165TA</td><td rowspan="7">  </td><td> <table border="1"> <tr><td>LN846RP-LS</td><td rowspan="7">  </td></tr> <tr><td>MA700ATA</td></tr> <tr><td>MA29WATA</td></tr> <tr><td>SVDS5688GT3</td></tr> <tr><td>1SS291TA</td></tr> <tr><td>P300DLF</td></tr> <tr><td>GP15GLF</td></tr> </table> </td></tr> <tr> <td> <table border="1"> <tr><td>MA4062MTA</td><td>MA4056MTA</td><td rowspan="7">  </td></tr> <tr><td>MA4068MTA</td><td>MA4030MTA</td></tr> <tr><td>MA4110MTA</td><td>MA4075HTA</td></tr> <tr><td>MA4360MTA</td><td>MA4043MTA</td></tr> <tr><td>MA4160LTA</td><td>MA4082MTA</td></tr> <tr><td>MA4120MTA</td><td></td></tr> <tr><td></td><td></td></tr> </table> </td> <td>UN4115TA</td> </tr> </table> </td></tr></table></td></tr></table></td></tr></table>	2SA933SQRSTA		<table border="1"> <tr><td>2SA992EFTA</td><td rowspan="7">  </td></tr> <tr><td>2SC2785FETA</td></tr> <tr><td>2SC2787LTA</td></tr> <tr><td>2SD1450QRSTA</td></tr> <tr><td>2SC3327ABTP</td></tr> <tr><td>2SC3311AQSTA</td></tr> <tr><td>2SA1309AQSTA</td></tr> </table>	2SA992EFTA		2SC2785FETA	2SC2787LTA	2SD1450QRSTA	2SC3327ABTP	2SC3311AQSTA	2SA1309AQSTA	2SJ40CDTA	<table border="1"> <tr><td>UN4113TA</td><td rowspan="2">  </td><td> <table border="1"> <tr><td>UN4211TA</td><td rowspan="3">  </td></tr> <tr><td>UN4111TA</td></tr> <tr><td>UN4214TA</td></tr> <tr><td>UN4213TA</td></tr> </table> </td></tr> <tr> <td>2SB1187DEF</td><td> <table border="1"> <tr><td>UN4215TA</td><td rowspan="2">  </td><td> <table border="1"> <tr><td>2SB1240PRTV6</td><td rowspan="2">  </td></tr> <tr><td>2SD1761DEF</td></tr> </table> </td></tr> <tr> <td> <table border="1"> <tr><td>MA165TA</td><td rowspan="7">  </td><td> <table border="1"> <tr><td>LN846RP-LS</td><td rowspan="7">  </td></tr> <tr><td>MA700ATA</td></tr> <tr><td>MA29WATA</td></tr> <tr><td>SVDS5688GT3</td></tr> <tr><td>1SS291TA</td></tr> <tr><td>P300DLF</td></tr> <tr><td>GP15GLF</td></tr> </table> </td></tr> <tr> <td> <table border="1"> <tr><td>MA4062MTA</td><td>MA4056MTA</td><td rowspan="7">  </td></tr> <tr><td>MA4068MTA</td><td>MA4030MTA</td></tr> <tr><td>MA4110MTA</td><td>MA4075HTA</td></tr> <tr><td>MA4360MTA</td><td>MA4043MTA</td></tr> <tr><td>MA4160LTA</td><td>MA4082MTA</td></tr> <tr><td>MA4120MTA</td><td></td></tr> <tr><td></td><td></td></tr> </table> </td> <td>UN4115TA</td> </tr> </table> </td></tr></table></td></tr></table>	UN4113TA		<table border="1"> <tr><td>UN4211TA</td><td rowspan="3">  </td></tr> <tr><td>UN4111TA</td></tr> <tr><td>UN4214TA</td></tr> <tr><td>UN4213TA</td></tr> </table>	UN4211TA		UN4111TA	UN4214TA	UN4213TA	2SB1187DEF	<table border="1"> <tr><td>UN4215TA</td><td rowspan="2">  </td><td> <table border="1"> <tr><td>2SB1240PRTV6</td><td rowspan="2">  </td></tr> <tr><td>2SD1761DEF</td></tr> </table> </td></tr> <tr> <td> <table border="1"> <tr><td>MA165TA</td><td rowspan="7">  </td><td> <table border="1"> <tr><td>LN846RP-LS</td><td rowspan="7">  </td></tr> <tr><td>MA700ATA</td></tr> <tr><td>MA29WATA</td></tr> <tr><td>SVDS5688GT3</td></tr> <tr><td>1SS291TA</td></tr> <tr><td>P300DLF</td></tr> <tr><td>GP15GLF</td></tr> </table> </td></tr> <tr> <td> <table border="1"> <tr><td>MA4062MTA</td><td>MA4056MTA</td><td rowspan="7">  </td></tr> <tr><td>MA4068MTA</td><td>MA4030MTA</td></tr> <tr><td>MA4110MTA</td><td>MA4075HTA</td></tr> <tr><td>MA4360MTA</td><td>MA4043MTA</td></tr> <tr><td>MA4160LTA</td><td>MA4082MTA</td></tr> <tr><td>MA4120MTA</td><td></td></tr> <tr><td></td><td></td></tr> </table> </td> <td>UN4115TA</td> </tr> </table> </td></tr></table>	UN4215TA		<table border="1"> <tr><td>2SB1240PRTV6</td><td rowspan="2">  </td></tr> <tr><td>2SD1761DEF</td></tr> </table>	2SB1240PRTV6		2SD1761DEF	<table border="1"> <tr><td>MA165TA</td><td rowspan="7">  </td><td> <table border="1"> <tr><td>LN846RP-LS</td><td rowspan="7">  </td></tr> <tr><td>MA700ATA</td></tr> <tr><td>MA29WATA</td></tr> <tr><td>SVDS5688GT3</td></tr> <tr><td>1SS291TA</td></tr> <tr><td>P300DLF</td></tr> <tr><td>GP15GLF</td></tr> </table> </td></tr> <tr> <td> <table border="1"> <tr><td>MA4062MTA</td><td>MA4056MTA</td><td rowspan="7">  </td></tr> <tr><td>MA4068MTA</td><td>MA4030MTA</td></tr> <tr><td>MA4110MTA</td><td>MA4075HTA</td></tr> <tr><td>MA4360MTA</td><td>MA4043MTA</td></tr> <tr><td>MA4160LTA</td><td>MA4082MTA</td></tr> <tr><td>MA4120MTA</td><td></td></tr> <tr><td></td><td></td></tr> </table> </td> <td>UN4115TA</td> </tr> </table>	MA165TA		<table border="1"> <tr><td>LN846RP-LS</td><td rowspan="7">  </td></tr> <tr><td>MA700ATA</td></tr> <tr><td>MA29WATA</td></tr> <tr><td>SVDS5688GT3</td></tr> <tr><td>1SS291TA</td></tr> <tr><td>P300DLF</td></tr> <tr><td>GP15GLF</td></tr> </table>	LN846RP-LS		MA700ATA	MA29WATA	SVDS5688GT3	1SS291TA	P300DLF	GP15GLF	<table border="1"> <tr><td>MA4062MTA</td><td>MA4056MTA</td><td rowspan="7">  </td></tr> <tr><td>MA4068MTA</td><td>MA4030MTA</td></tr> <tr><td>MA4110MTA</td><td>MA4075HTA</td></tr> <tr><td>MA4360MTA</td><td>MA4043MTA</td></tr> <tr><td>MA4160LTA</td><td>MA4082MTA</td></tr> <tr><td>MA4120MTA</td><td></td></tr> <tr><td></td><td></td></tr> </table>	MA4062MTA	MA4056MTA		MA4068MTA	MA4030MTA	MA4110MTA	MA4075HTA	MA4360MTA	MA4043MTA	MA4160LTA	MA4082MTA	MA4120MTA				UN4115TA
M5238P	8 Pin																																																																																									
AN6558F																																																																																										
AN6552F																																																																																										
M5218P																																																																																										
AN6554F	14 Pin																																																																																									
<table border="1"> <tr><td>LM7001</td><td rowspan="8">16 Pin</td></tr> <tr><td>AN7470</td></tr> <tr><td>TC74HC42AP</td></tr> <tr><td>TC4051BP</td></tr> <tr><td>MN4028B</td></tr> <tr><td>XR-1091DCP</td></tr> <tr><td>SVITA7629P</td></tr> <tr><td>TC9214P</td></tr> <tr><td>AN7273A</td><td>18 Pin</td></tr> <tr><td>TC9212P</td><td>20 Pin</td></tr> <tr><td>M50198P</td><td>24 Pin</td></tr> <tr><td>TC9163N</td><td rowspan="2">28 Pin</td></tr> <tr><td>LC7522</td></tr> </table> 	LM7001	16 Pin	AN7470	TC74HC42AP	TC4051BP	MN4028B	XR-1091DCP	SVITA7629P	TC9214P		AN7273A	18 Pin	TC9212P	20 Pin	M50198P	24 Pin	TC9163N	28 Pin	LC7522	<table border="1"> <tr><td>BA6218</td><td>9 Pin</td></tr> <tr><td>M5241L</td><td>10 Pin</td></tr> </table> 	BA6218	9 Pin	M5241L	10 Pin																																																																		
LM7001	16 Pin																																																																																									
AN7470																																																																																										
TC74HC42AP																																																																																										
TC4051BP																																																																																										
MN4028B																																																																																										
XR-1091DCP																																																																																										
SVITA7629P																																																																																										
TC9214P																																																																																										
AN7273A	18 Pin																																																																																									
TC9212P	20 Pin																																																																																									
M50198P	24 Pin																																																																																									
TC9163N	28 Pin																																																																																									
LC7522																																																																																										
BA6218	9 Pin																																																																																									
M5241L	10 Pin																																																																																									
<table border="1"> <tr><td>2SA933SQRSTA</td><td rowspan="7">  </td><td> <table border="1"> <tr><td>2SA992EFTA</td><td rowspan="7">  </td></tr> <tr><td>2SC2785FETA</td></tr> <tr><td>2SC2787LTA</td></tr> <tr><td>2SD1450QRSTA</td></tr> <tr><td>2SC3327ABTP</td></tr> <tr><td>2SC3311AQSTA</td></tr> <tr><td>2SA1309AQSTA</td></tr> </table> </td></tr> <tr> <td>2SJ40CDTA</td><td> <table border="1"> <tr><td>UN4113TA</td><td rowspan="2">  </td><td> <table border="1"> <tr><td>UN4211TA</td><td rowspan="3">  </td></tr> <tr><td>UN4111TA</td></tr> <tr><td>UN4214TA</td></tr> <tr><td>UN4213TA</td></tr> </table> </td></tr> <tr> <td>2SB1187DEF</td><td> <table border="1"> <tr><td>UN4215TA</td><td rowspan="2">  </td><td> <table border="1"> <tr><td>2SB1240PRTV6</td><td rowspan="2">  </td></tr> <tr><td>2SD1761DEF</td></tr> </table> </td></tr> <tr> <td> <table border="1"> <tr><td>MA165TA</td><td rowspan="7">  </td><td> <table border="1"> <tr><td>LN846RP-LS</td><td rowspan="7">  </td></tr> <tr><td>MA700ATA</td></tr> <tr><td>MA29WATA</td></tr> <tr><td>SVDS5688GT3</td></tr> <tr><td>1SS291TA</td></tr> <tr><td>P300DLF</td></tr> <tr><td>GP15GLF</td></tr> </table> </td></tr> <tr> <td> <table border="1"> <tr><td>MA4062MTA</td><td>MA4056MTA</td><td rowspan="7">  </td></tr> <tr><td>MA4068MTA</td><td>MA4030MTA</td></tr> <tr><td>MA4110MTA</td><td>MA4075HTA</td></tr> <tr><td>MA4360MTA</td><td>MA4043MTA</td></tr> <tr><td>MA4160LTA</td><td>MA4082MTA</td></tr> <tr><td>MA4120MTA</td><td></td></tr> <tr><td></td><td></td></tr> </table> </td> <td>UN4115TA</td> </tr> </table> </td></tr></table></td></tr></table></td></tr></table>	2SA933SQRSTA		<table border="1"> <tr><td>2SA992EFTA</td><td rowspan="7">  </td></tr> <tr><td>2SC2785FETA</td></tr> <tr><td>2SC2787LTA</td></tr> <tr><td>2SD1450QRSTA</td></tr> <tr><td>2SC3327ABTP</td></tr> <tr><td>2SC3311AQSTA</td></tr> <tr><td>2SA1309AQSTA</td></tr> </table>	2SA992EFTA		2SC2785FETA	2SC2787LTA	2SD1450QRSTA	2SC3327ABTP	2SC3311AQSTA	2SA1309AQSTA	2SJ40CDTA	<table border="1"> <tr><td>UN4113TA</td><td rowspan="2">  </td><td> <table border="1"> <tr><td>UN4211TA</td><td rowspan="3">  </td></tr> <tr><td>UN4111TA</td></tr> <tr><td>UN4214TA</td></tr> <tr><td>UN4213TA</td></tr> </table> </td></tr> <tr> <td>2SB1187DEF</td><td> <table border="1"> <tr><td>UN4215TA</td><td rowspan="2">  </td><td> <table border="1"> <tr><td>2SB1240PRTV6</td><td rowspan="2">  </td></tr> <tr><td>2SD1761DEF</td></tr> </table> </td></tr> <tr> <td> <table border="1"> <tr><td>MA165TA</td><td rowspan="7">  </td><td> <table border="1"> <tr><td>LN846RP-LS</td><td rowspan="7">  </td></tr> <tr><td>MA700ATA</td></tr> <tr><td>MA29WATA</td></tr> <tr><td>SVDS5688GT3</td></tr> <tr><td>1SS291TA</td></tr> <tr><td>P300DLF</td></tr> <tr><td>GP15GLF</td></tr> </table> </td></tr> <tr> <td> <table border="1"> <tr><td>MA4062MTA</td><td>MA4056MTA</td><td rowspan="7">  </td></tr> <tr><td>MA4068MTA</td><td>MA4030MTA</td></tr> <tr><td>MA4110MTA</td><td>MA4075HTA</td></tr> <tr><td>MA4360MTA</td><td>MA4043MTA</td></tr> <tr><td>MA4160LTA</td><td>MA4082MTA</td></tr> <tr><td>MA4120MTA</td><td></td></tr> <tr><td></td><td></td></tr> </table> </td> <td>UN4115TA</td> </tr> </table> </td></tr></table></td></tr></table>	UN4113TA		<table border="1"> <tr><td>UN4211TA</td><td rowspan="3">  </td></tr> <tr><td>UN4111TA</td></tr> <tr><td>UN4214TA</td></tr> <tr><td>UN4213TA</td></tr> </table>	UN4211TA		UN4111TA	UN4214TA	UN4213TA	2SB1187DEF	<table border="1"> <tr><td>UN4215TA</td><td rowspan="2">  </td><td> <table border="1"> <tr><td>2SB1240PRTV6</td><td rowspan="2">  </td></tr> <tr><td>2SD1761DEF</td></tr> </table> </td></tr> <tr> <td> <table border="1"> <tr><td>MA165TA</td><td rowspan="7">  </td><td> <table border="1"> <tr><td>LN846RP-LS</td><td rowspan="7">  </td></tr> <tr><td>MA700ATA</td></tr> <tr><td>MA29WATA</td></tr> <tr><td>SVDS5688GT3</td></tr> <tr><td>1SS291TA</td></tr> <tr><td>P300DLF</td></tr> <tr><td>GP15GLF</td></tr> </table> </td></tr> <tr> <td> <table border="1"> <tr><td>MA4062MTA</td><td>MA4056MTA</td><td rowspan="7">  </td></tr> <tr><td>MA4068MTA</td><td>MA4030MTA</td></tr> <tr><td>MA4110MTA</td><td>MA4075HTA</td></tr> <tr><td>MA4360MTA</td><td>MA4043MTA</td></tr> <tr><td>MA4160LTA</td><td>MA4082MTA</td></tr> <tr><td>MA4120MTA</td><td></td></tr> <tr><td></td><td></td></tr> </table> </td> <td>UN4115TA</td> </tr> </table> </td></tr></table>	UN4215TA		<table border="1"> <tr><td>2SB1240PRTV6</td><td rowspan="2">  </td></tr> <tr><td>2SD1761DEF</td></tr> </table>	2SB1240PRTV6		2SD1761DEF	<table border="1"> <tr><td>MA165TA</td><td rowspan="7">  </td><td> <table border="1"> <tr><td>LN846RP-LS</td><td rowspan="7">  </td></tr> <tr><td>MA700ATA</td></tr> <tr><td>MA29WATA</td></tr> <tr><td>SVDS5688GT3</td></tr> <tr><td>1SS291TA</td></tr> <tr><td>P300DLF</td></tr> <tr><td>GP15GLF</td></tr> </table> </td></tr> <tr> <td> <table border="1"> <tr><td>MA4062MTA</td><td>MA4056MTA</td><td rowspan="7">  </td></tr> <tr><td>MA4068MTA</td><td>MA4030MTA</td></tr> <tr><td>MA4110MTA</td><td>MA4075HTA</td></tr> <tr><td>MA4360MTA</td><td>MA4043MTA</td></tr> <tr><td>MA4160LTA</td><td>MA4082MTA</td></tr> <tr><td>MA4120MTA</td><td></td></tr> <tr><td></td><td></td></tr> </table> </td> <td>UN4115TA</td> </tr> </table>	MA165TA		<table border="1"> <tr><td>LN846RP-LS</td><td rowspan="7">  </td></tr> <tr><td>MA700ATA</td></tr> <tr><td>MA29WATA</td></tr> <tr><td>SVDS5688GT3</td></tr> <tr><td>1SS291TA</td></tr> <tr><td>P300DLF</td></tr> <tr><td>GP15GLF</td></tr> </table>	LN846RP-LS		MA700ATA	MA29WATA	SVDS5688GT3	1SS291TA	P300DLF	GP15GLF	<table border="1"> <tr><td>MA4062MTA</td><td>MA4056MTA</td><td rowspan="7">  </td></tr> <tr><td>MA4068MTA</td><td>MA4030MTA</td></tr> <tr><td>MA4110MTA</td><td>MA4075HTA</td></tr> <tr><td>MA4360MTA</td><td>MA4043MTA</td></tr> <tr><td>MA4160LTA</td><td>MA4082MTA</td></tr> <tr><td>MA4120MTA</td><td></td></tr> <tr><td></td><td></td></tr> </table>	MA4062MTA	MA4056MTA		MA4068MTA	MA4030MTA	MA4110MTA	MA4075HTA	MA4360MTA	MA4043MTA	MA4160LTA	MA4082MTA	MA4120MTA				UN4115TA																																
2SA933SQRSTA			<table border="1"> <tr><td>2SA992EFTA</td><td rowspan="7">  </td></tr> <tr><td>2SC2785FETA</td></tr> <tr><td>2SC2787LTA</td></tr> <tr><td>2SD1450QRSTA</td></tr> <tr><td>2SC3327ABTP</td></tr> <tr><td>2SC3311AQSTA</td></tr> <tr><td>2SA1309AQSTA</td></tr> </table>	2SA992EFTA			2SC2785FETA	2SC2787LTA	2SD1450QRSTA	2SC3327ABTP	2SC3311AQSTA	2SA1309AQSTA																																																																														
2SA992EFTA																																																																																										
2SC2785FETA																																																																																										
2SC2787LTA																																																																																										
2SD1450QRSTA																																																																																										
2SC3327ABTP																																																																																										
2SC3311AQSTA																																																																																										
2SA1309AQSTA																																																																																										
2SJ40CDTA	<table border="1"> <tr><td>UN4113TA</td><td rowspan="2">  </td><td> <table border="1"> <tr><td>UN4211TA</td><td rowspan="3">  </td></tr> <tr><td>UN4111TA</td></tr> <tr><td>UN4214TA</td></tr> <tr><td>UN4213TA</td></tr> </table> </td></tr> <tr> <td>2SB1187DEF</td><td> <table border="1"> <tr><td>UN4215TA</td><td rowspan="2">  </td><td> <table border="1"> <tr><td>2SB1240PRTV6</td><td rowspan="2">  </td></tr> <tr><td>2SD1761DEF</td></tr> </table> </td></tr> <tr> <td> <table border="1"> <tr><td>MA165TA</td><td rowspan="7">  </td><td> <table border="1"> <tr><td>LN846RP-LS</td><td rowspan="7">  </td></tr> <tr><td>MA700ATA</td></tr> <tr><td>MA29WATA</td></tr> <tr><td>SVDS5688GT3</td></tr> <tr><td>1SS291TA</td></tr> <tr><td>P300DLF</td></tr> <tr><td>GP15GLF</td></tr> </table> </td></tr> <tr> <td> <table border="1"> <tr><td>MA4062MTA</td><td>MA4056MTA</td><td rowspan="7">  </td></tr> <tr><td>MA4068MTA</td><td>MA4030MTA</td></tr> <tr><td>MA4110MTA</td><td>MA4075HTA</td></tr> <tr><td>MA4360MTA</td><td>MA4043MTA</td></tr> <tr><td>MA4160LTA</td><td>MA4082MTA</td></tr> <tr><td>MA4120MTA</td><td></td></tr> <tr><td></td><td></td></tr> </table> </td> <td>UN4115TA</td> </tr> </table> </td></tr></table></td></tr></table>	UN4113TA		<table border="1"> <tr><td>UN4211TA</td><td rowspan="3">  </td></tr> <tr><td>UN4111TA</td></tr> <tr><td>UN4214TA</td></tr> <tr><td>UN4213TA</td></tr> </table>	UN4211TA		UN4111TA	UN4214TA	UN4213TA	2SB1187DEF	<table border="1"> <tr><td>UN4215TA</td><td rowspan="2">  </td><td> <table border="1"> <tr><td>2SB1240PRTV6</td><td rowspan="2">  </td></tr> <tr><td>2SD1761DEF</td></tr> </table> </td></tr> <tr> <td> <table border="1"> <tr><td>MA165TA</td><td rowspan="7">  </td><td> <table border="1"> <tr><td>LN846RP-LS</td><td rowspan="7">  </td></tr> <tr><td>MA700ATA</td></tr> <tr><td>MA29WATA</td></tr> <tr><td>SVDS5688GT3</td></tr> <tr><td>1SS291TA</td></tr> <tr><td>P300DLF</td></tr> <tr><td>GP15GLF</td></tr> </table> </td></tr> <tr> <td> <table border="1"> <tr><td>MA4062MTA</td><td>MA4056MTA</td><td rowspan="7">  </td></tr> <tr><td>MA4068MTA</td><td>MA4030MTA</td></tr> <tr><td>MA4110MTA</td><td>MA4075HTA</td></tr> <tr><td>MA4360MTA</td><td>MA4043MTA</td></tr> <tr><td>MA4160LTA</td><td>MA4082MTA</td></tr> <tr><td>MA4120MTA</td><td></td></tr> <tr><td></td><td></td></tr> </table> </td> <td>UN4115TA</td> </tr> </table> </td></tr></table>	UN4215TA		<table border="1"> <tr><td>2SB1240PRTV6</td><td rowspan="2">  </td></tr> <tr><td>2SD1761DEF</td></tr> </table>	2SB1240PRTV6		2SD1761DEF	<table border="1"> <tr><td>MA165TA</td><td rowspan="7">  </td><td> <table border="1"> <tr><td>LN846RP-LS</td><td rowspan="7">  </td></tr> <tr><td>MA700ATA</td></tr> <tr><td>MA29WATA</td></tr> <tr><td>SVDS5688GT3</td></tr> <tr><td>1SS291TA</td></tr> <tr><td>P300DLF</td></tr> <tr><td>GP15GLF</td></tr> </table> </td></tr> <tr> <td> <table border="1"> <tr><td>MA4062MTA</td><td>MA4056MTA</td><td rowspan="7">  </td></tr> <tr><td>MA4068MTA</td><td>MA4030MTA</td></tr> <tr><td>MA4110MTA</td><td>MA4075HTA</td></tr> <tr><td>MA4360MTA</td><td>MA4043MTA</td></tr> <tr><td>MA4160LTA</td><td>MA4082MTA</td></tr> <tr><td>MA4120MTA</td><td></td></tr> <tr><td></td><td></td></tr> </table> </td> <td>UN4115TA</td> </tr> </table>	MA165TA		<table border="1"> <tr><td>LN846RP-LS</td><td rowspan="7">  </td></tr> <tr><td>MA700ATA</td></tr> <tr><td>MA29WATA</td></tr> <tr><td>SVDS5688GT3</td></tr> <tr><td>1SS291TA</td></tr> <tr><td>P300DLF</td></tr> <tr><td>GP15GLF</td></tr> </table>	LN846RP-LS		MA700ATA	MA29WATA	SVDS5688GT3	1SS291TA	P300DLF	GP15GLF	<table border="1"> <tr><td>MA4062MTA</td><td>MA4056MTA</td><td rowspan="7">  </td></tr> <tr><td>MA4068MTA</td><td>MA4030MTA</td></tr> <tr><td>MA4110MTA</td><td>MA4075HTA</td></tr> <tr><td>MA4360MTA</td><td>MA4043MTA</td></tr> <tr><td>MA4160LTA</td><td>MA4082MTA</td></tr> <tr><td>MA4120MTA</td><td></td></tr> <tr><td></td><td></td></tr> </table>	MA4062MTA	MA4056MTA		MA4068MTA	MA4030MTA	MA4110MTA	MA4075HTA	MA4360MTA	MA4043MTA	MA4160LTA	MA4082MTA	MA4120MTA				UN4115TA																																												
UN4113TA		<table border="1"> <tr><td>UN4211TA</td><td rowspan="3">  </td></tr> <tr><td>UN4111TA</td></tr> <tr><td>UN4214TA</td></tr> <tr><td>UN4213TA</td></tr> </table>		UN4211TA			UN4111TA	UN4214TA	UN4213TA																																																																																	
UN4211TA																																																																																										
UN4111TA																																																																																										
UN4214TA																																																																																										
UN4213TA																																																																																										
2SB1187DEF	<table border="1"> <tr><td>UN4215TA</td><td rowspan="2">  </td><td> <table border="1"> <tr><td>2SB1240PRTV6</td><td rowspan="2">  </td></tr> <tr><td>2SD1761DEF</td></tr> </table> </td></tr> <tr> <td> <table border="1"> <tr><td>MA165TA</td><td rowspan="7">  </td><td> <table border="1"> <tr><td>LN846RP-LS</td><td rowspan="7">  </td></tr> <tr><td>MA700ATA</td></tr> <tr><td>MA29WATA</td></tr> <tr><td>SVDS5688GT3</td></tr> <tr><td>1SS291TA</td></tr> <tr><td>P300DLF</td></tr> <tr><td>GP15GLF</td></tr> </table> </td></tr> <tr> <td> <table border="1"> <tr><td>MA4062MTA</td><td>MA4056MTA</td><td rowspan="7">  </td></tr> <tr><td>MA4068MTA</td><td>MA4030MTA</td></tr> <tr><td>MA4110MTA</td><td>MA4075HTA</td></tr> <tr><td>MA4360MTA</td><td>MA4043MTA</td></tr> <tr><td>MA4160LTA</td><td>MA4082MTA</td></tr> <tr><td>MA4120MTA</td><td></td></tr> <tr><td></td><td></td></tr> </table> </td> <td>UN4115TA</td> </tr> </table> </td></tr></table>	UN4215TA		<table border="1"> <tr><td>2SB1240PRTV6</td><td rowspan="2">  </td></tr> <tr><td>2SD1761DEF</td></tr> </table>	2SB1240PRTV6		2SD1761DEF	<table border="1"> <tr><td>MA165TA</td><td rowspan="7">  </td><td> <table border="1"> <tr><td>LN846RP-LS</td><td rowspan="7">  </td></tr> <tr><td>MA700ATA</td></tr> <tr><td>MA29WATA</td></tr> <tr><td>SVDS5688GT3</td></tr> <tr><td>1SS291TA</td></tr> <tr><td>P300DLF</td></tr> <tr><td>GP15GLF</td></tr> </table> </td></tr> <tr> <td> <table border="1"> <tr><td>MA4062MTA</td><td>MA4056MTA</td><td rowspan="7">  </td></tr> <tr><td>MA4068MTA</td><td>MA4030MTA</td></tr> <tr><td>MA4110MTA</td><td>MA4075HTA</td></tr> <tr><td>MA4360MTA</td><td>MA4043MTA</td></tr> <tr><td>MA4160LTA</td><td>MA4082MTA</td></tr> <tr><td>MA4120MTA</td><td></td></tr> <tr><td></td><td></td></tr> </table> </td> <td>UN4115TA</td> </tr> </table>	MA165TA		<table border="1"> <tr><td>LN846RP-LS</td><td rowspan="7">  </td></tr> <tr><td>MA700ATA</td></tr> <tr><td>MA29WATA</td></tr> <tr><td>SVDS5688GT3</td></tr> <tr><td>1SS291TA</td></tr> <tr><td>P300DLF</td></tr> <tr><td>GP15GLF</td></tr> </table>	LN846RP-LS		MA700ATA	MA29WATA	SVDS5688GT3	1SS291TA	P300DLF	GP15GLF		<table border="1"> <tr><td>MA4062MTA</td><td>MA4056MTA</td><td rowspan="7">  </td></tr> <tr><td>MA4068MTA</td><td>MA4030MTA</td></tr> <tr><td>MA4110MTA</td><td>MA4075HTA</td></tr> <tr><td>MA4360MTA</td><td>MA4043MTA</td></tr> <tr><td>MA4160LTA</td><td>MA4082MTA</td></tr> <tr><td>MA4120MTA</td><td></td></tr> <tr><td></td><td></td></tr> </table>	MA4062MTA		MA4056MTA		MA4068MTA	MA4030MTA	MA4110MTA	MA4075HTA	MA4360MTA	MA4043MTA	MA4160LTA		MA4082MTA	MA4120MTA				UN4115TA																																																			
UN4215TA		<table border="1"> <tr><td>2SB1240PRTV6</td><td rowspan="2">  </td></tr> <tr><td>2SD1761DEF</td></tr> </table>		2SB1240PRTV6			2SD1761DEF																																																																																			
2SB1240PRTV6																																																																																										
2SD1761DEF																																																																																										
<table border="1"> <tr><td>MA165TA</td><td rowspan="7">  </td><td> <table border="1"> <tr><td>LN846RP-LS</td><td rowspan="7">  </td></tr> <tr><td>MA700ATA</td></tr> <tr><td>MA29WATA</td></tr> <tr><td>SVDS5688GT3</td></tr> <tr><td>1SS291TA</td></tr> <tr><td>P300DLF</td></tr> <tr><td>GP15GLF</td></tr> </table> </td></tr> <tr> <td> <table border="1"> <tr><td>MA4062MTA</td><td>MA4056MTA</td><td rowspan="7">  </td></tr> <tr><td>MA4068MTA</td><td>MA4030MTA</td></tr> <tr><td>MA4110MTA</td><td>MA4075HTA</td></tr> <tr><td>MA4360MTA</td><td>MA4043MTA</td></tr> <tr><td>MA4160LTA</td><td>MA4082MTA</td></tr> <tr><td>MA4120MTA</td><td></td></tr> <tr><td></td><td></td></tr> </table> </td> <td>UN4115TA</td> </tr> </table>	MA165TA		<table border="1"> <tr><td>LN846RP-LS</td><td rowspan="7">  </td></tr> <tr><td>MA700ATA</td></tr> <tr><td>MA29WATA</td></tr> <tr><td>SVDS5688GT3</td></tr> <tr><td>1SS291TA</td></tr> <tr><td>P300DLF</td></tr> <tr><td>GP15GLF</td></tr> </table>	LN846RP-LS		MA700ATA	MA29WATA	SVDS5688GT3	1SS291TA		P300DLF	GP15GLF		<table border="1"> <tr><td>MA4062MTA</td><td>MA4056MTA</td><td rowspan="7">  </td></tr> <tr><td>MA4068MTA</td><td>MA4030MTA</td></tr> <tr><td>MA4110MTA</td><td>MA4075HTA</td></tr> <tr><td>MA4360MTA</td><td>MA4043MTA</td></tr> <tr><td>MA4160LTA</td><td>MA4082MTA</td></tr> <tr><td>MA4120MTA</td><td></td></tr> <tr><td></td><td></td></tr> </table>	MA4062MTA	MA4056MTA		MA4068MTA	MA4030MTA	MA4110MTA	MA4075HTA	MA4360MTA	MA4043MTA	MA4160LTA		MA4082MTA	MA4120MTA				UN4115TA																																																											
MA165TA			<table border="1"> <tr><td>LN846RP-LS</td><td rowspan="7">  </td></tr> <tr><td>MA700ATA</td></tr> <tr><td>MA29WATA</td></tr> <tr><td>SVDS5688GT3</td></tr> <tr><td>1SS291TA</td></tr> <tr><td>P300DLF</td></tr> <tr><td>GP15GLF</td></tr> </table>	LN846RP-LS			MA700ATA	MA29WATA	SVDS5688GT3		1SS291TA	P300DLF		GP15GLF																																																																												
LN846RP-LS																																																																																										
MA700ATA																																																																																										
MA29WATA																																																																																										
SVDS5688GT3																																																																																										
1SS291TA																																																																																										
P300DLF																																																																																										
GP15GLF																																																																																										
<table border="1"> <tr><td>MA4062MTA</td><td>MA4056MTA</td><td rowspan="7">  </td></tr> <tr><td>MA4068MTA</td><td>MA4030MTA</td></tr> <tr><td>MA4110MTA</td><td>MA4075HTA</td></tr> <tr><td>MA4360MTA</td><td>MA4043MTA</td></tr> <tr><td>MA4160LTA</td><td>MA4082MTA</td></tr> <tr><td>MA4120MTA</td><td></td></tr> <tr><td></td><td></td></tr> </table>	MA4062MTA	MA4056MTA		MA4068MTA	MA4030MTA	MA4110MTA	MA4075HTA	MA4360MTA	MA4043MTA	MA4160LTA	MA4082MTA	MA4120MTA				UN4115TA																																																																										
MA4062MTA	MA4056MTA																																																																																									
MA4068MTA	MA4030MTA																																																																																									
MA4110MTA	MA4075HTA																																																																																									
MA4360MTA	MA4043MTA																																																																																									
MA4160LTA	MA4082MTA																																																																																									
MA4120MTA																																																																																										

INTERNAL CONNECTION OF FL

• Grid connection diagram

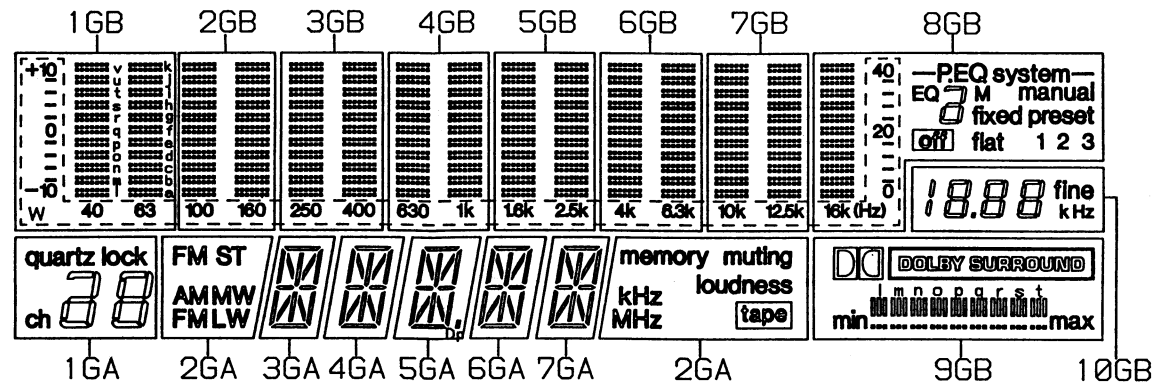

• Anode connection table (A)

	1GB	2GB	3GB	4GB	5GB	6GB	7GB	8GB	9GB	10GB
aB	3	DOLBY SURROUND	K,DP
bB	2	-	fine
cB	1	-	c
dB	manual	-	d
eB	flat	-	e
fB	fixed	-	f
gB	M	-	g
hB	off	-	h
iB	i	-	i
jB	j	-	j
kB	k	-	k
lB	l
mB	m
nB	n
oB	o
pB	p
qB	q
rB	r
sB	s
tB	t
uB	u
vB	min.....max	/
wB	40,63	100,160	250,400	600,1K	1.6K,2.5K	4K,6.3K	10K,12.5K	-P,EQ system - preset - 16K(Hz)	Hz
xB	-	-	-	-	-	-	-	x	-	-

• Anode connection table (B)

	1GA	2GA	3GA	4GA	5GA	6GA	7GA
aA	a	KHz	a	a	a	a	a
bA	b	LW	b	b	b	b	b
cA	c	-	c	c	c	c	c
dA	d	muting	d	d	d	d	d
eA	e	tape	e	e	e	e	e
fA	f	FM	f	f	f	f	f
gA	g	-	g	g	g	g	g
hA	h	AM	h	h	h	h	h
iA	i	MW	i	i	i	i	i
jA	j	MHz	j	j	j	j	j
kA	quartz lock	loudness	k	k	k	k	k
lA	-	memory	l	l	l	l	l
mA	ch	FM ST	-	-	DP	-	-

• Pin connection

62	61	60	59	58	57	56	55	54	53	52	51	50	49	48	47
F	F	N	N	k	d	l	c	e	g	b	f	i	h	j	a
2	2	P	P	A	A	A	A	A	A	A	A	A	A	A	A
46	45	44	43	42	41	40	39	38	37	36	35	34	33	32	31
1	2	3	4	5	6	7	8	9	10	11	12	13	14	15	16
G	G	G	G	G	G	G	m	G	G	G	G	G	G	G	G
A	A	A	A	A	A	A	A	B	B	B	B	B	B	B	B
30	29	28	27	26	25	24	23	22	21	20	19	18	17	16	
9	10	x	w	v	u	t	s	r	q	p	o	n	m	l	
G	G	B	B	B	B	B	B	B	B	B	B	B	B	B	
15	14	13	12	11	10	9	8	7	6	5	4	3	2	1	
k	j	i	h	g	f	e	d	c	b	a	N	N	F	F	
B	B	B	B	B	B	B	B	B	B	B	P	P	1	1	

SCHEMATIC DIAGRAM

(Parts list on pages 56~63.)

(This schematic diagram may be modified at any time with the development of new technology.)

Note 1:

- **S351** : Slope changeover switch [slope (Q)].
- **S355** : Fixed preset switch (fixed preset).
- **S356~358** : Equalization preset switches (manual preset).
[S356: 1, S357: 2, S358: 3]
- **S359** : Parametric EQ system memory switch (P. EQ system memory).
- **S360** : Display mode switch (display mode).
- **S361** : Parametric EQ system ON/OFF switch (parametric EQ system).
- **S362** : Fine mode select switch (fine on/off).
- **S363** : Dolby surround ON/OFF switch (Dolby Surround).
- **S364, 365** : Rear speaker volume control switches (rear level).
[S364: down, S365: up]
- **S601** : Speaker selectors switches (speakers).
[S601-1: A, S601-2: B]
- **S701** : Power "standby / on" switch (power).
- **S901~910** : Preset-tuning switches (24 channel random preset tuning).
[S901: 1, S902: 2, S903: 3, S904: 4,
S905: 5, S906: 6, S907: 7, S908: 8,
S909: 9, S910: 0]
- **S911** : Memory scan switch (memory scan).
- **S912** : FM mode selector switch (FM mode).
- **S913, 914** : Band selector switches.
[S913: FM, S914: AM]
- **S917** : Memory switch (memory).
- **S918** : Loudness switch (loudness).
- **S927~931** : Input selector switches.
[S927: phono, S928: tuner, S929: CD,
S930: VCR2, S931: VCR1]
- **S932** : Tape-monitor switch (tape monitor).
- **S933** : Tuning mode selector switch (tuning mode).

- Signal line**
- : FM OSC
 - ▨▨▨▨ : AM OSC
 - ▨▨▨▨ : Phono signal (Lch)
 - ▨▨▨▨ : Spectrum analyzer signal
 - ▨▨▨▨ : Dolby surround signal (Lch)
 - ▨▨▨▨ : P. Equalizer signal (Lch)
 - ▨▨▨▨ : Positive voltage lines
 - ▨▨▨▨ : Negative voltage lines
 - ▨▨▨▨ : FM signal
 - ▨▨▨▨ : AM signal
 - ▨▨▨▨ : AF signal (Lch)

- Important safety notice:**
Components identified by Δ mark have special characteristics important for safety. When replacing any of these components, use only manufacturer's specified parts. Indicated voltage values are standard values for the unit measured by the DC electronic circuit tester (high-impedance) with the chassis taken as standard. Therefore, there may exist some errors in the voltage values, depending on internal impedance of the DC circuit tester.
- All voltage values shown in circuitry are DC voltage in FM signal (Stereo signal) reception mode.
- *Figures in () Stand for DC-voltage in AM signal reception mode.

Caution!
IC and LSI are sensitive to static electricity. Secondary trouble can be prevented by taking care during repair.

- Cover the parts boxes made of plastics with aluminum foil.
- Ground the soldering iron.
- Put a conductive mat on the work table.
- Do not touch the legs of IC or LSI with the fingers directly.

Note2:
• Use of ceramic filters in pairs
The ceramic filters (CF201, CF202) for FM-IF circuit are available in three ranks. For this circuit, be sure to use the ceramics of the same rank in a pair. At repairing and replacement, pay close attention to the diodes (D914, D915) for use as different diodes must be used depending on each rank of the ceramic filters.

RANK (Color)	D914	D915	CENTER FREQUENCY
Blue	○	×	10.675MHz
Red	○	○	10.700MHz
Orange	×	○	10.725MHz

Color marking (Blue, Red or Orange)

SFE 10.7MHz

Note: ○ mark: Diode is used.
× mark: Diode is not used.

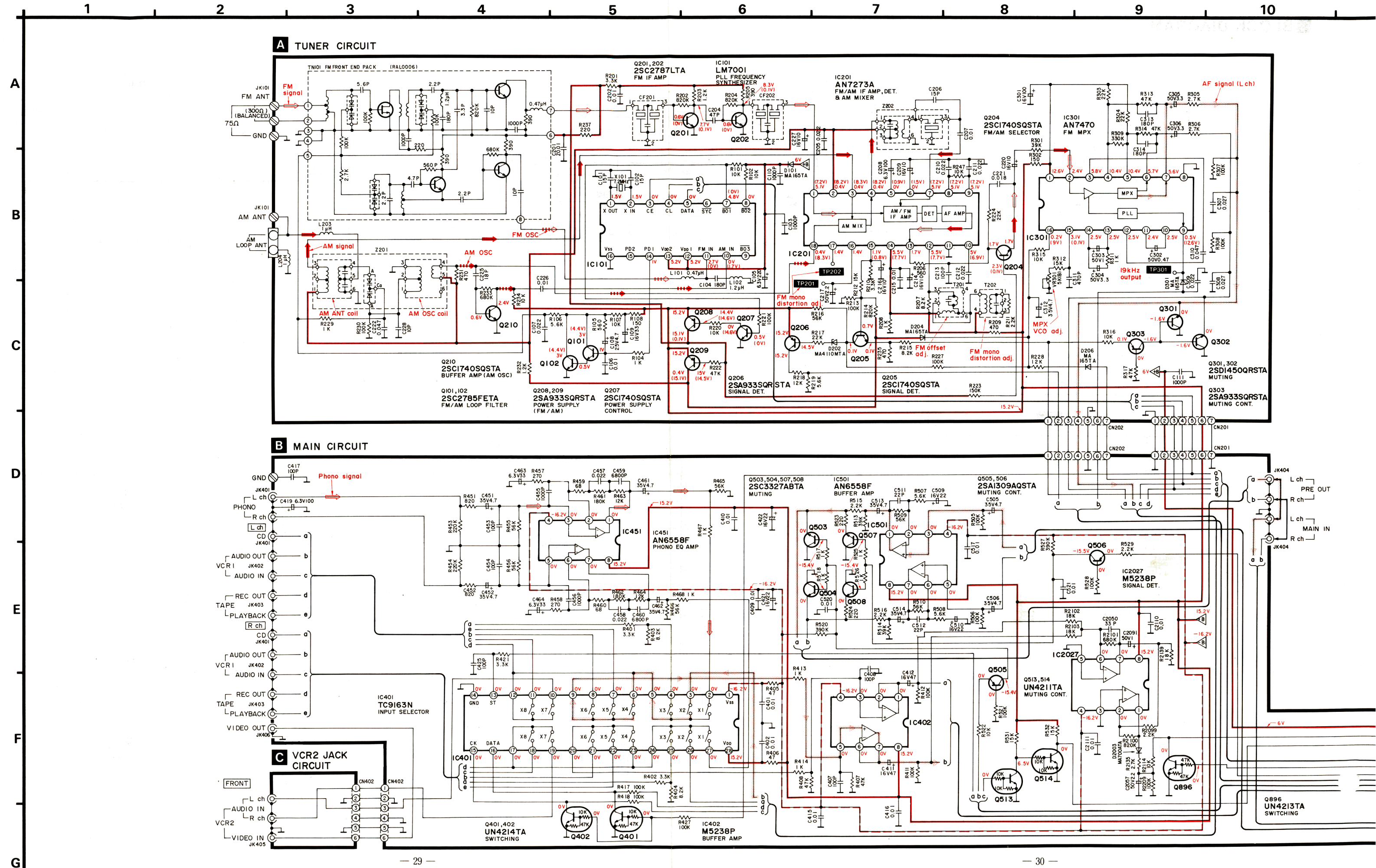

D FL DRIVE CIRCUIT

E OPERATION CIRCUIT

F REMOTE SENSOR CIRCUIT

G TONE CONTROL/REQ VR CIRCUIT

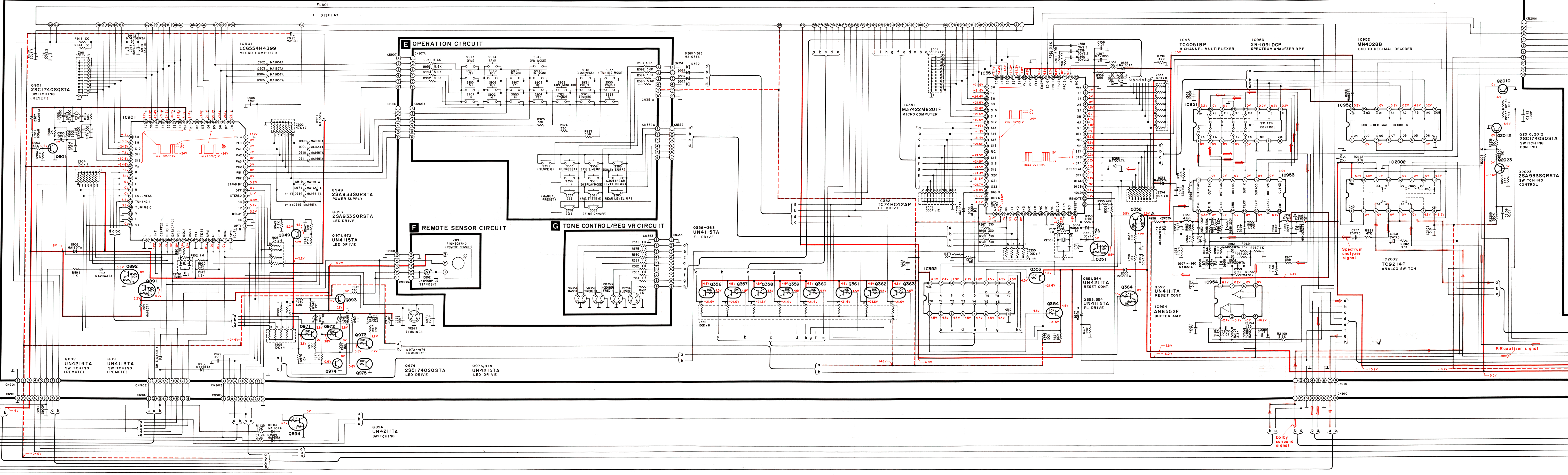

M SURROUND CIRCUIT

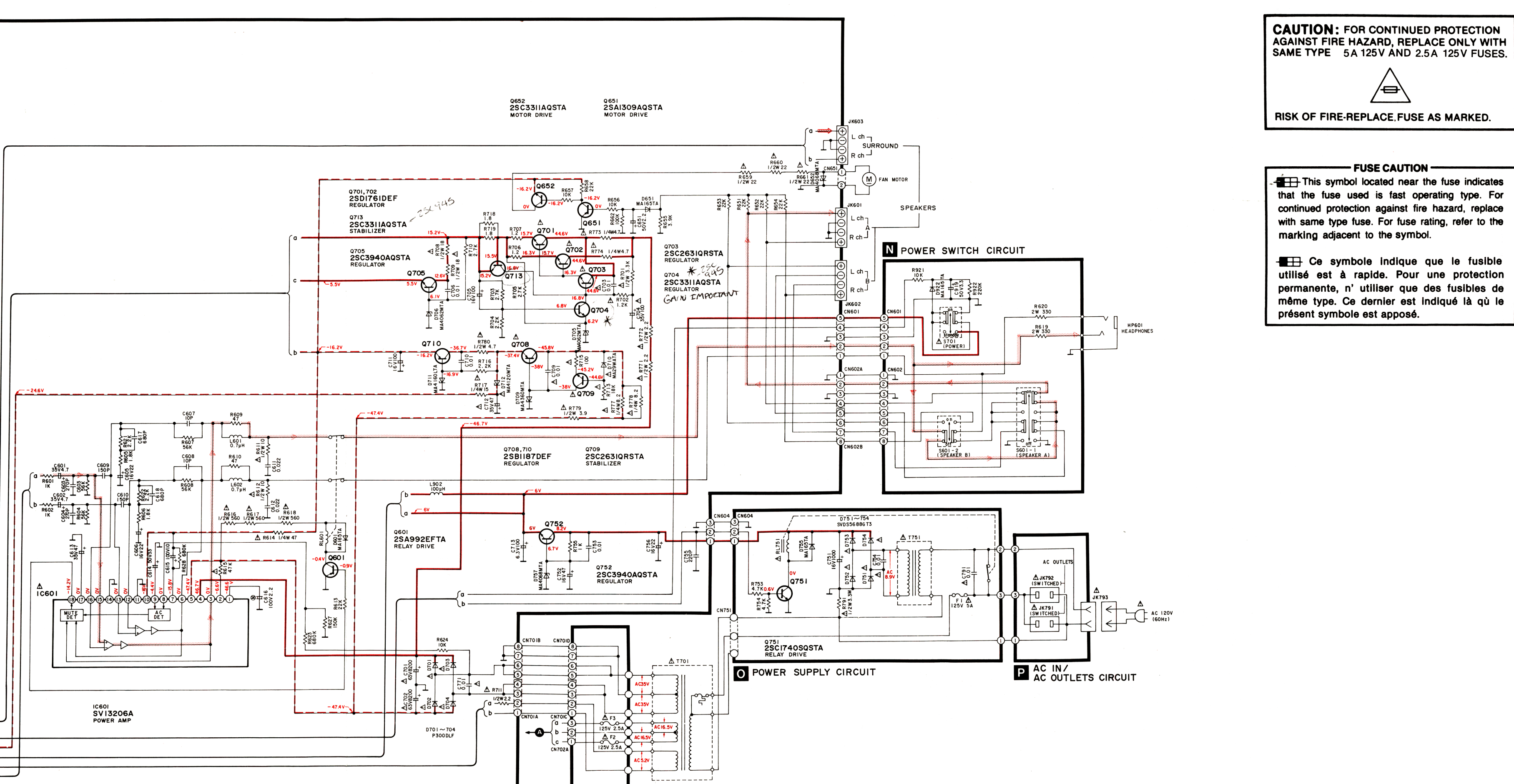
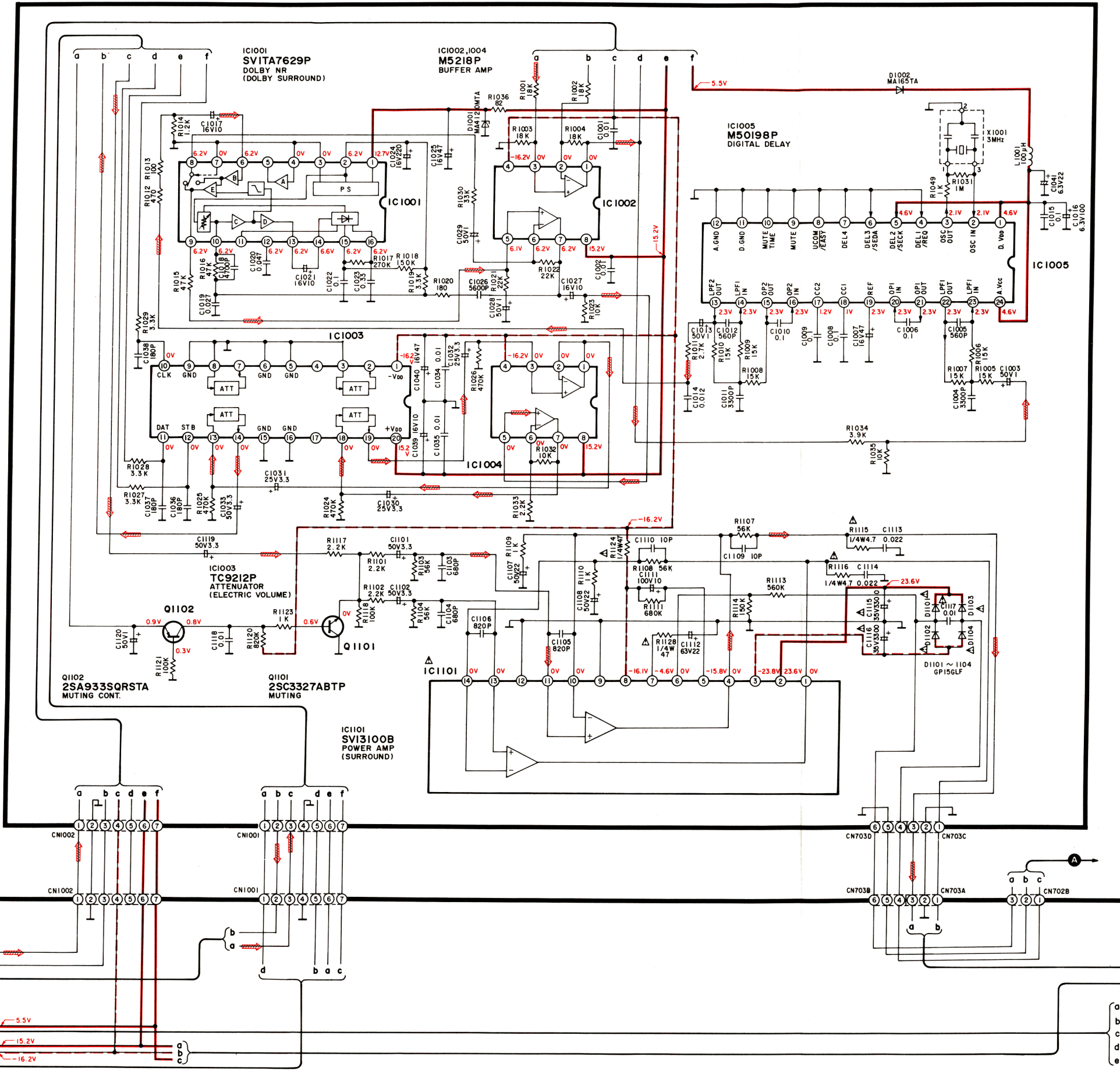

CAUTION: FOR CONTINUED PROTECTION AGAINST FIRE HAZARD, REPLACE ONLY WITH SAME TYPE 5A 125V AND 2.5A 125V FUSES.

RISK OF FIRE-REPLACE FUSE AS MARKED.

FUSE CAUTION

This symbol located near the fuse indicates that the fuse used is fast operating type. For continued protection against fire hazard, replace with same type fuse. For fuse rating, refer to the marking adjacent to the symbol.

Ce symbole indique que le fusible utilisé est à rapide. Pour une protection permanente, n'utiliser que des fusibles de même type. Ce dernier est indiqué là où le présent symbole est apposé.

E OPERATION P.C.B.

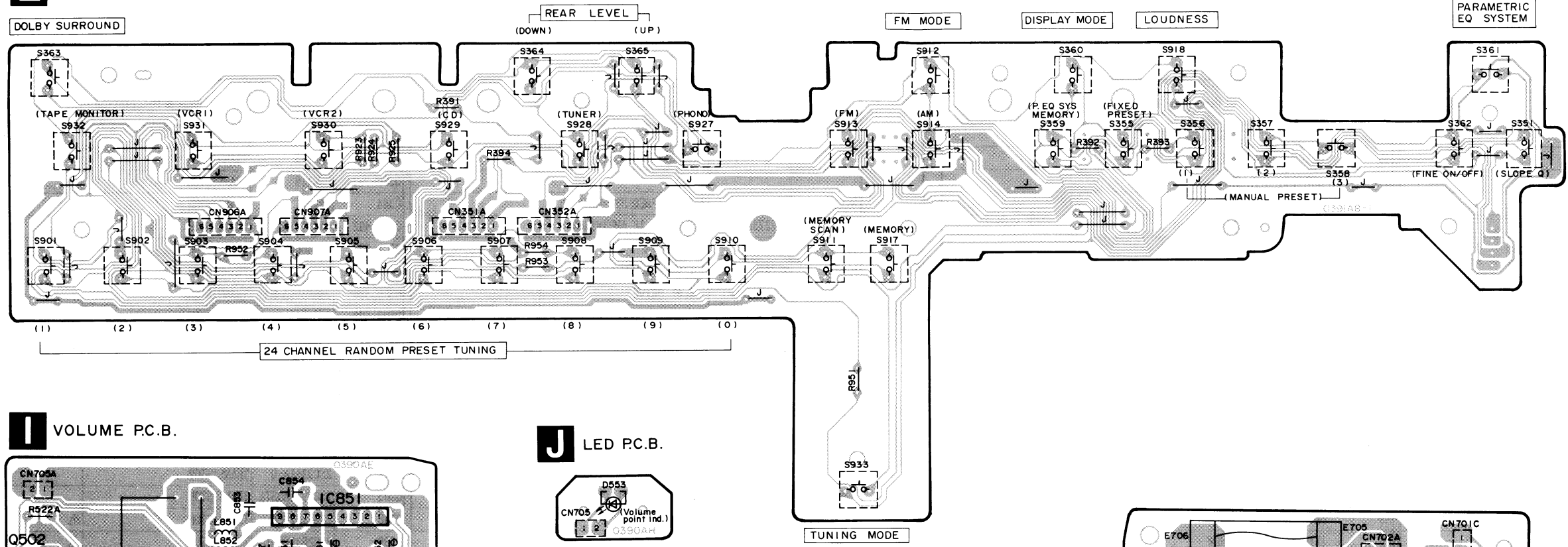

I VOLUME P.C.B.

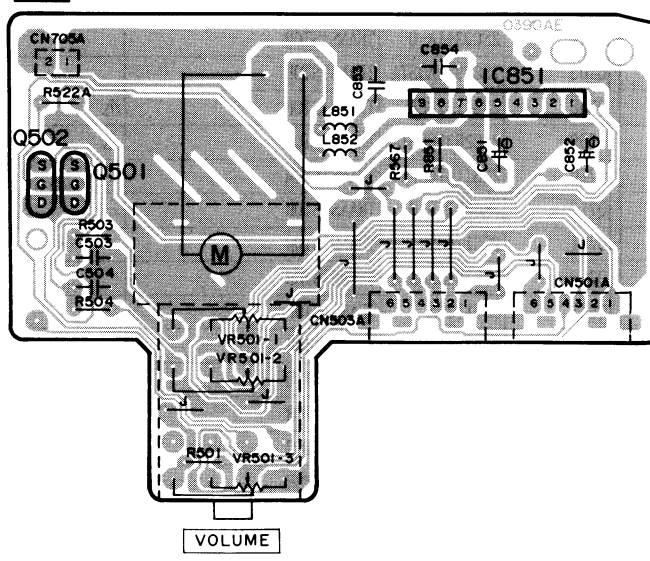

J LED P.C.B.

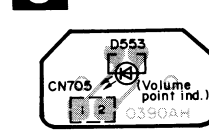

N POWER SWITCH P.C.B.

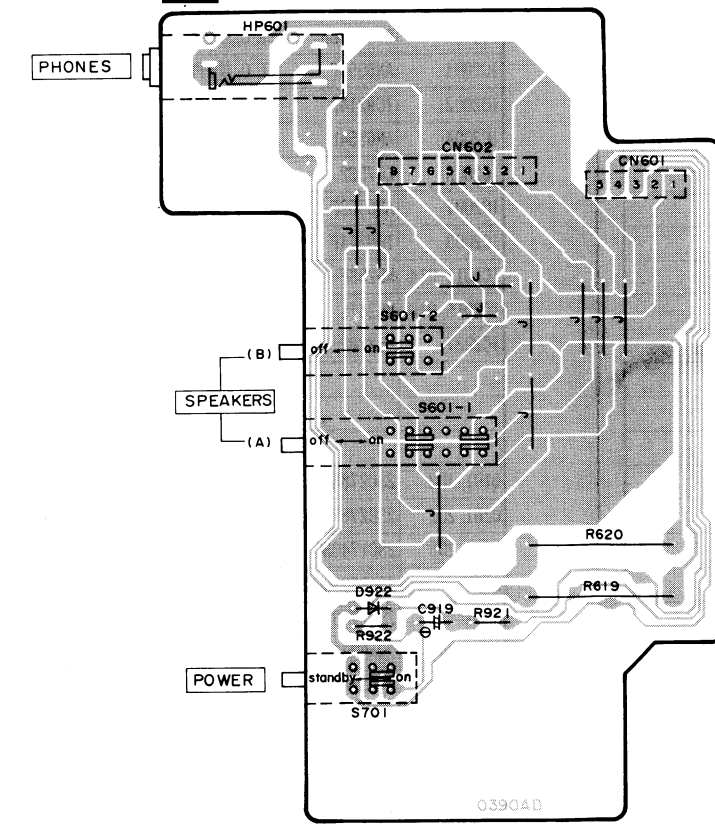

G TONE CONTROL / P.EQ VR P.C.B.

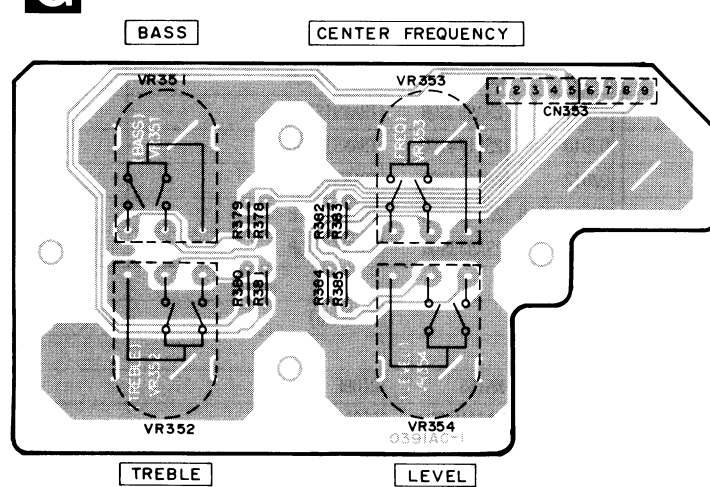

M SURROUND P.C.B.

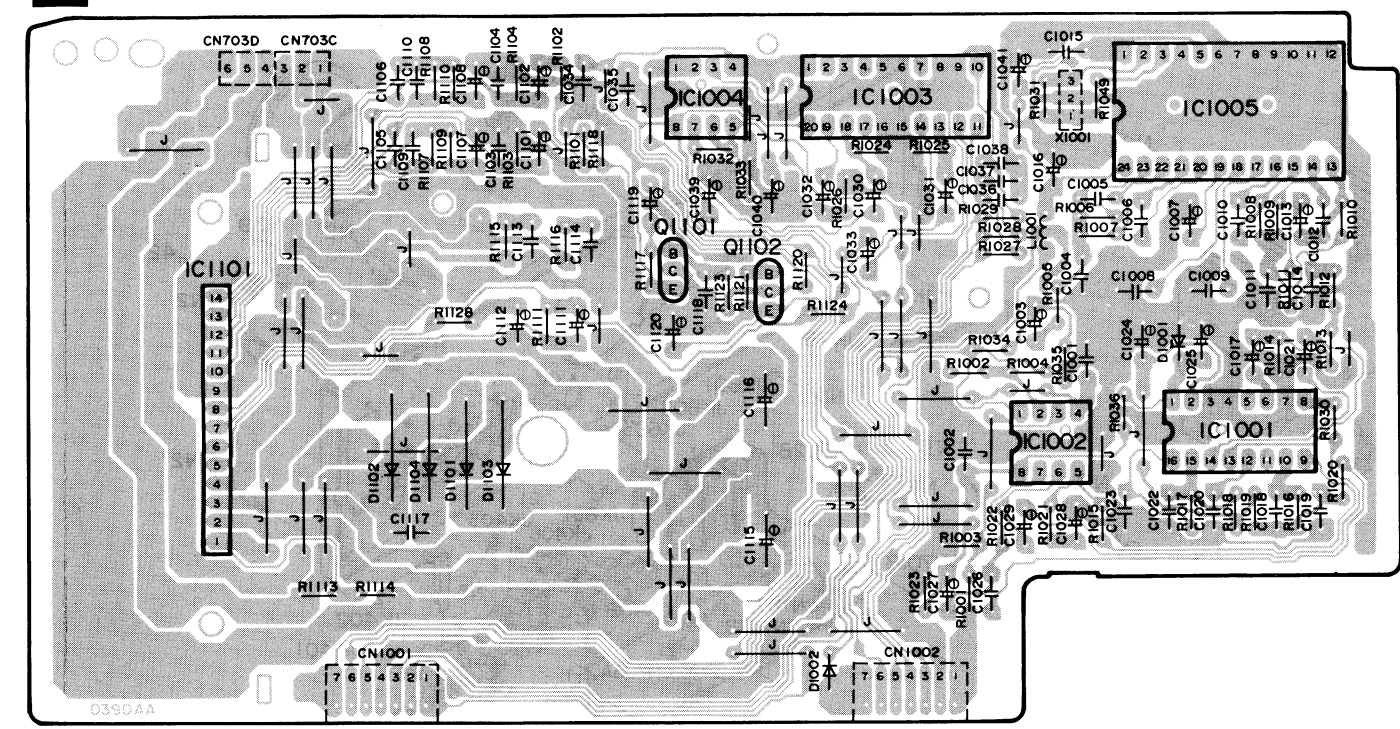

H PARAMETRIC EQ P.C.B.

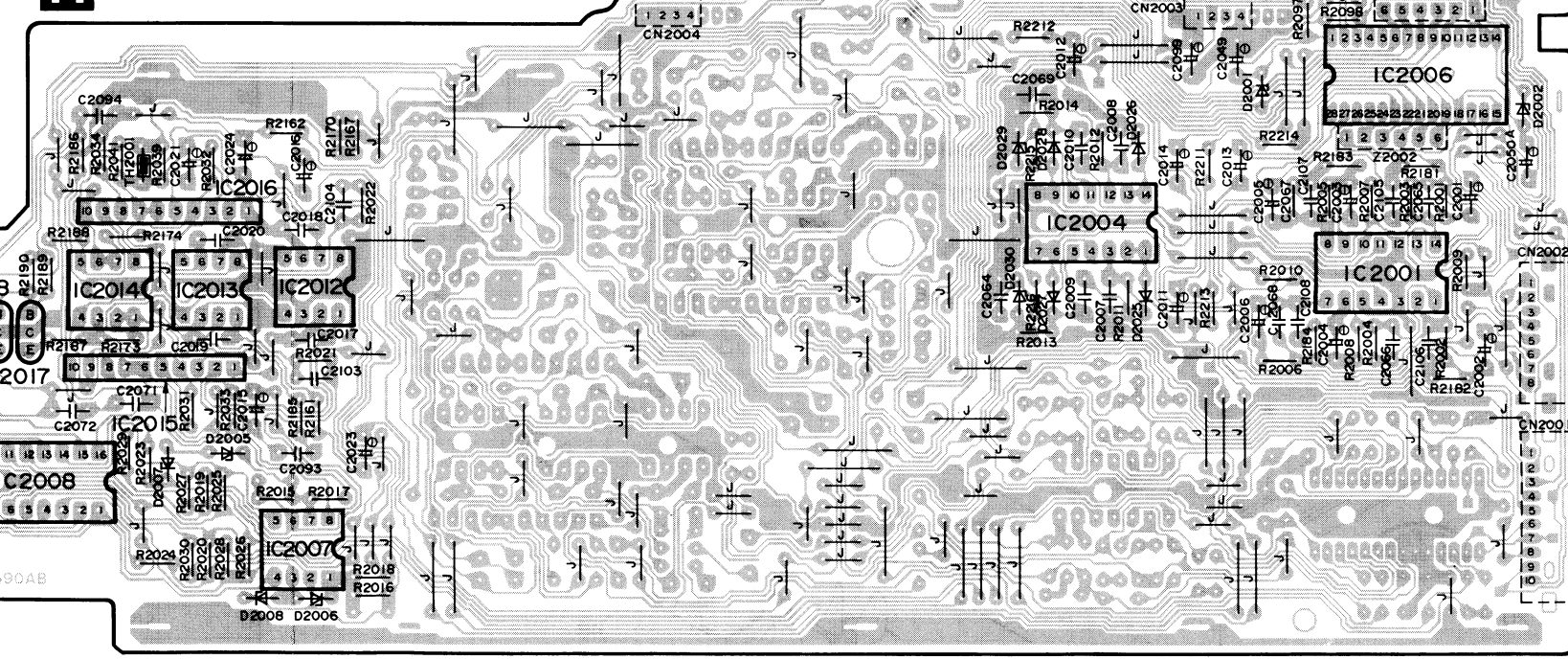

O POWER SUPPLY P.C.B.

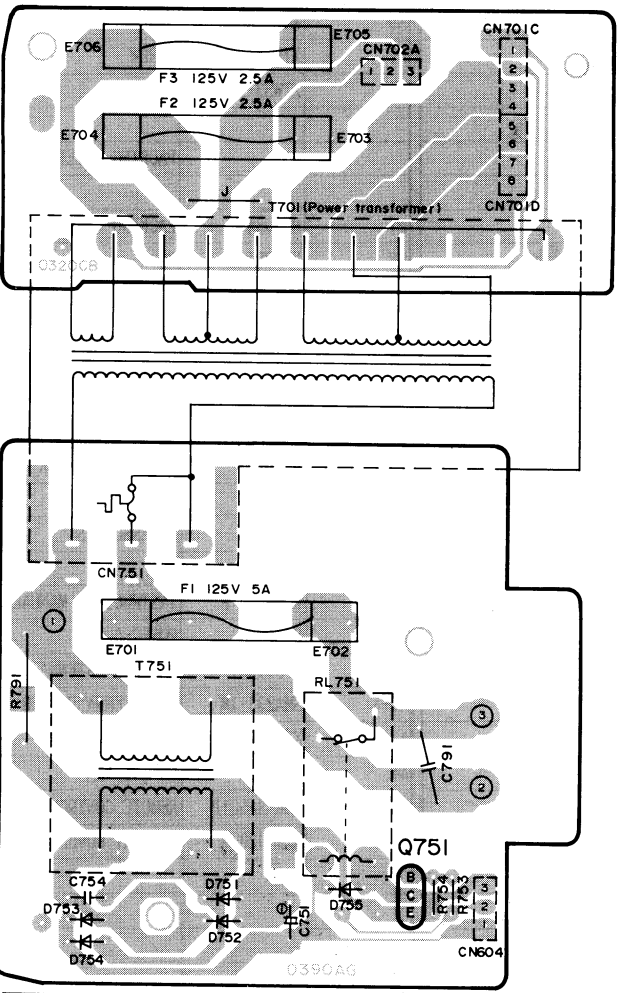

WIRING CONNECTION DIAGRAM

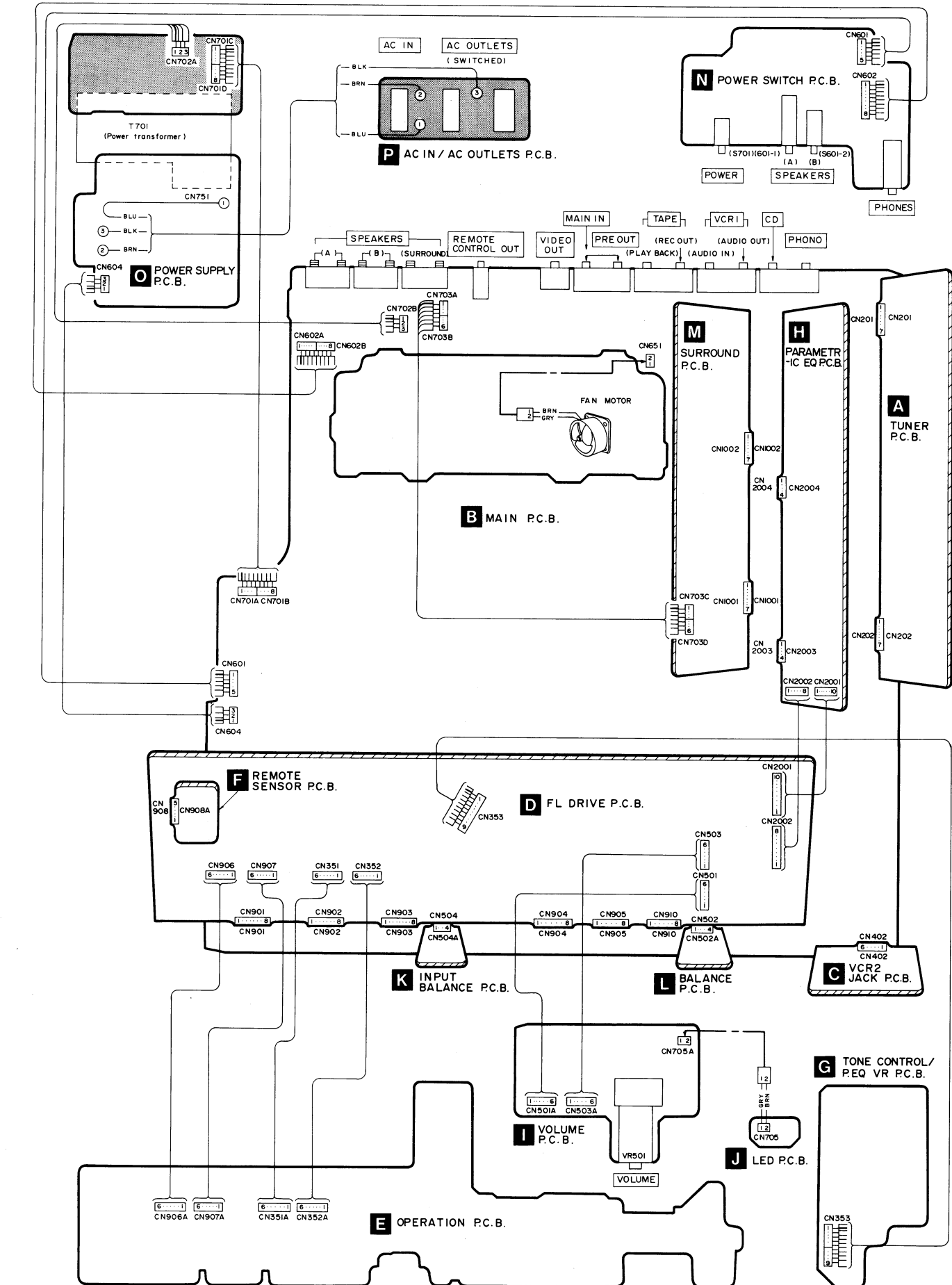

EXPLODED VIEW

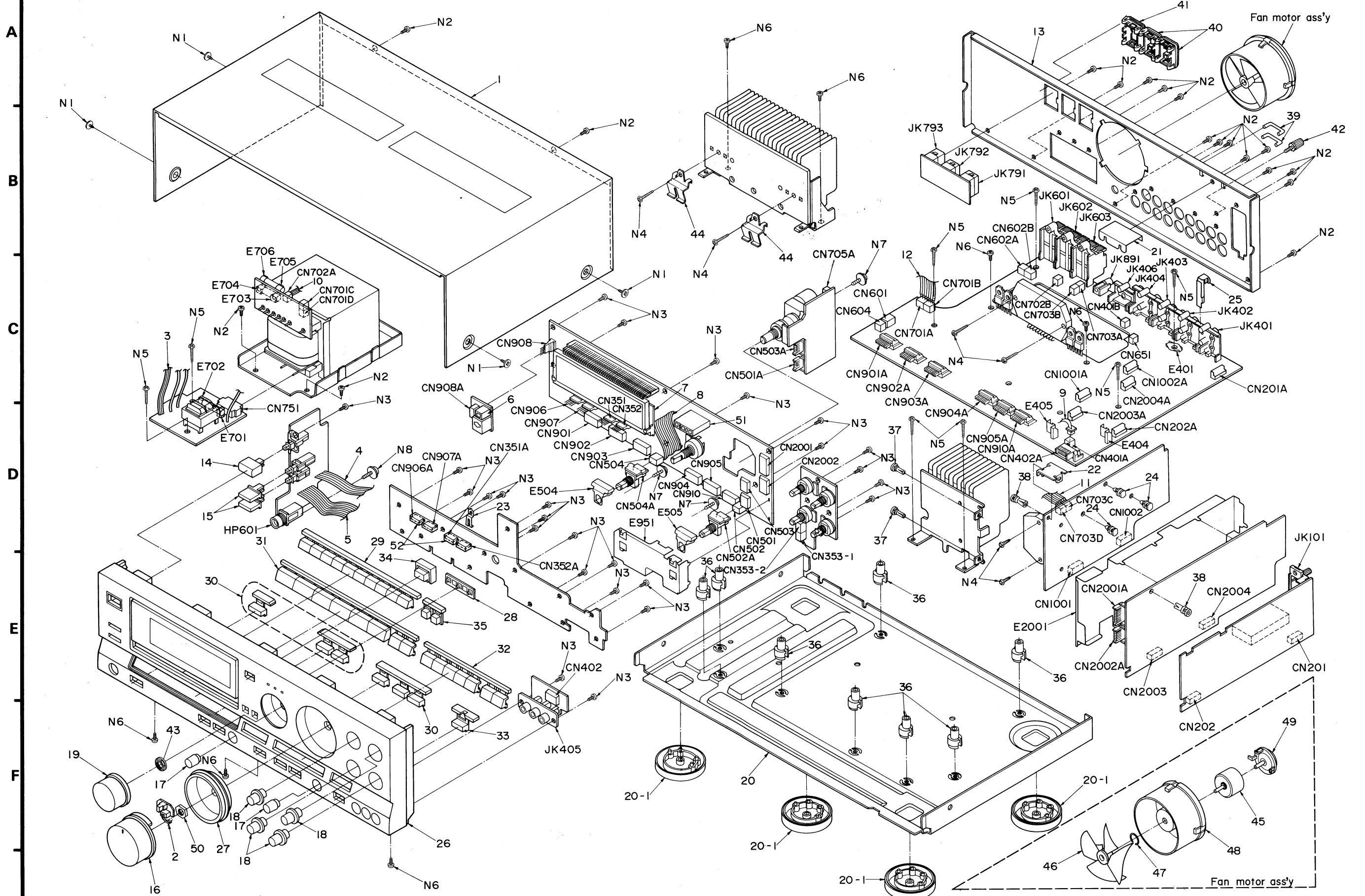

REPLACEMENT PARTS LIST

Notes : * Important safety notice:
 Components identified by Δ mark have special characteristics important for safety. When replacing any of these components use only manufacturer's specified parts.
 The parenthesized indications in the Remarks columns specify the areas. (Refer to the cover page for area.)
 Parts without these indications can be used for all areas.

Ref. No.	Part No.	Part Name & Description	Remarks
CABINET AND CHASSIS			
1	RQMD016A-K	CABINET	
2	REED023	CONNECTOR ASS'Y (2P) (CN705)	
3	FWJ1803120QK	FLAT CABLE (3P) (CN604)	
4	FWJ1805150QK	FLAT CABLE (5P) (CN601)	
5	FWJ180330QK	FLAT CABLE (8P) (CN602)	
6	FMND069	LED HOLDER	
7	FMND079	FL HOLDER	
8	FWJ1809200QK	FLAT CABLE (9P) (CN353)	
9	REL28H360X	CONNECTOR (2P)	
10	FWJ1803210QK	FLAT CABLE (3P) (CN702)	
11	FWJ1806470QK	FLAT CABLE (6P) (CN703)	
12	FWJ1808160QK	FLAT CABLE (8P) (CN701)	
13	RGRO080C-A	REAR PANEL	
14	RGU0030	BUTTON, POWER	
15	RGU0101	BUTTON, SPEAKER SELECTOR	
16	RGW0021	KNOB, MAIN VOLUME	
17	RGW0073	KNOB, BALANCE	
18	RGW0083	KNOB, P. EQ VOL	
19	RGW0085	KNOB, TUNING	
20	RFKJAGX500PP	CHASSIS ASS'Y	
20-1	RKAD009-1	FOOT	
21	RMA0295	P. C. B. SUPPORT ANGLE	
22	RMA0310	P. C. B. SUPPORT ANGLE	
23	RMCO082	EARTH ANGLE	
24	FMND086	SPACER	
25	RSC0105	SHIELD PLATE	
26	RFKJAGX500PP	FRONT PANEL ASS'Y	
27	RGK0266	VOLUME ORNAMENT	
28	RGL0087	PANEL LIGHT	
29	RGU0344A	BUTTON, PRESET	
30	RGU0348B	BUTTON, MODE	
31	RGU0394A	BUTTON, SELECTOR	
32	RGU0395A	BUTTON, P. OFF	
33	RGU0396	BUTTON, EQ ON/OFF	
34	RGU0397	BUTTON, TUNING	
35	RGU0399	BUTTON, MEMORY	
36	SHE187-2	P. C. B. SUPPORT	
37	SHR411	LATCH	
38	SHR415	LATCH	
39	SJP9205-2T	SHORT PIN	
40	SJS9233A	AC OUTLET COVER	
41	SJS9234A	AC INLET COVER	
42	SNE2123	GND TERMINAL	
43	SNE4021	NUT	
44	SUS894	ANGLE, TRANSISTOR	
45	MDN-4RB4MVA	MOTOR	
46	SHE222	FAN	
47	SUS271	SPRING	
48	SHE233	FAN CASE	
49	SHE234	CAP	
50	XNS75	NUT	
51	LN031527PH	LED HOLDER (D972-D974)	
52	SMC6466	SHIELD PLATE	
SCREWS			
N1	SNE2129-3	SCREW	
N2	XTBS3+8JFZ1	SCREW	
N3	XTBS26+8J	SCREW	
N4	XTB3+16JFZ	SCREW	
N5	XTB3+20JFZ	SCREW	
N6	XTB3+8JFZ	SCREW	
N7	XTWS3+8T	SCREW	
N8	XTWS3+10Q	SCREW	
PACKING MATERIAL			
P1	RPQ0543	PACKING CASE	
P2	RPND324A	PAD	
P3	RPND324B	PAD	
P4	RPND324C	PAD	
P5	RPND324D	PAD	
P6	XZB60X60A01	PROTECTION BAG (UNIT)	
P7	XZB24X33C04	PROTECTION BAG (F. B.)	
P8	SPSD152	ACCESSORIES BOX	
ACCESSORIES			
A1	RQT0554-P	INSTRUCTION MANUAL	
A2	SJA172	POWER CORD	Δ
A3	SPB1163T	AM LOOP ANTENNA	
A3-1	SMA233-1M	AN ANTENNA HOLDER	
A3-2	XTN3+10AFZ	SCREWS	
A4	SSA272M	FM ANTENNA	
A5	RAK-SA501P	REMOTE CONTROL TRANSMITTER	
A6	RKKD020-K	BATTERY COVER	

Notes : * Important safety notice:
 Components identified by Δ mark have special characteristics important for safety. When replacing any of these components use only manufacturer's specified parts.
 The parenthesized indications in the Remarks columns specify the areas. (Refer to the cover page for area.)
 Parts without these indications can be used for all areas.

Ref. No.	Part No.	Part Name & Description	Remarks
INTEGRATED CIRCUIT(S)			
IC101	LM7001	I. C. PLL FREQ. SYNTHESIZER	
IC201	AN7273A	I. C. FM/AM IF AMP&MIXER	
IC301	AN7470	I. C. FM MPX	
IC351	M37422M6201F	I. C. MICROCOMPUTER	
IC352	TC74HC42AP	I. C. FL. DRIVE	
IC401	TC9163N	I. C. INPUT SELECTOR	
IC402	MS238P-1	I. C. BUFFER AMP	
IC451	AN6558F	I. C. PHONO EQ. AMP	
IC501	AN6558F	I. C. BUFFER AMP	
IC601	SV13206A	I. C. POWER AMP	Δ
IC851	BA6218	I. C. MOTOR DRIVE	
IC901	LC6554H4399	I. C. MICROCOMPUTER	
IC951	TC4051BP	I. C. FREQUENCY SELECTOR	
IC952	MN4028B	I. C. BCD/DECIMAL DECODER	
IC953	XR-1091DCP	I. C. B. P. F.	
IC954	AN6552F	I. C. BUFFER AMP	
IC1001	SV17A7629P	I. C. DOLBY B NR	
IC1002	MS218P	I. C. MIXING AMP & FILTER AMP	
IC1003	TC9212P	I. C. ATT./VOLUME CONTROL	
IC1004	MS218P	I. C. BUFFER AMP	
IC1005	MS0198P	I. C. DIGITAL DELAY	
IC1101	SV13100B	I. C. SURROUND POWER AMP	Δ
IC2001	AN6554F	I. C. BUFFER AMP	
IC2002	TC9214P	I. C. ANALOG SWITCH	
IC2004	AN6554F	I. C. B. P. F.	
IC2006	LC7522	I. C. BAND LEVEL CONTROL	
IC2007	AN6552F	I. C. SIGNAL DET.	
IC2008	TC9214P	I. C. ANALOG SWITCH	
IC2012-014	MS238P-1	I. C. BUFFER AMP	
IC2015, 016	MS241L	I. C. ATT./VOLUME CONTROL	
IC2027	MS238P-1	I. C. MIXING & BUFFER AMP	
TRANSISTOR(S)			
Q101, 102	2SC2785FE	TRANSISTOR	
Q201, 202	2SC2787L	TRANSISTOR	
Q204, 205	2SC1740SQ	TRANSISTOR	
Q206	2SA933SQR	TRANSISTOR	
Q207	2SC1740SQ	TRANSISTOR	
Q208, 209	2SA933SQR	TRANSISTOR	
Q210	2SC1740SQ	TRANSISTOR	
Q301, 302	2SD1450QRSTA	TRANSISTOR	
Q303	2SA933SQR	TRANSISTOR	
Q351	UN4211	TRANSISTOR	
Q352	UN4111	TRANSISTOR	
Q353, 354	UN4115	TRANSISTOR	
Q356-363	UN4115	TRANSISTOR	
Q364	UN4211	TRANSISTOR	
Q401, 402	UN4214TA	TRANSISTOR	
Q501, 502	2SJ40CDA	TRANSISTOR	
Q503, 504	2SC3327-A	TRANSISTOR	
Q505, 506	2SA1309A-R	TRANSISTOR	
Q507, 508	2SC3327-A	TRANSISTOR	
Q513, 514	UN4211	TRANSISTOR	
Q601	2SA92EFTA	TRANSISTOR	
Q651	2SA1309A-R	TRANSISTOR	
Q652	2SC3311A-Q	TRANSISTOR	
Q701, 702	2SD176LDEF	TRANSISTOR	Δ
Q703	2SC2631QRSTA	TRANSISTOR	Δ
Q704	2SC3311A-Q	TRANSISTOR	
Q705	2SC3940AQSTA	TRANSISTOR	
Q708	2SB187DEF	TRANSISTOR	Δ
Q709	2SC2631QRSTA	TRANSISTOR	Δ
Q710	2SB187DEF	TRANSISTOR	
Q713	2SC3311A-Q	TRANSISTOR	
Q751	2SC1740SQ	TRANSISTOR	
Q752	2SC3940AQSTA	TRANSISTOR	
Q891	UN4113TA	TRANSISTOR	
Q892	UN4214TA	TRANSISTOR	
Q893	2SA933SQR	TRANSISTOR	
Q894	UN4211	TRANSISTOR	
Q895	2SB1240PRTV6	TRANSISTOR	
Q896	UN4213	TRANSISTOR	
Q901	2SC1740SQ	TRANSISTOR	
Q949	2SA933SQR	TRANSISTOR	
Q971, 972	UN4115	TRANSISTOR	
Q973	UN4215	TRANSISTOR	
Q974	2SC1740SQ	TRANSISTOR	
Q975	UN4215	TRANSISTOR	
Q1101	2SC3327-A	TRANSISTOR	
Q1102	2SA933SQR	TRANSISTOR	
Q2010	2SC1740SQ	TRANSISTOR	
Q2012	2SC1740SQ	TRANSISTOR	
Q2017, 2018	2SC3327-A	TRANSISTOR	
Q2023	2SA933SQR	TRANSISTOR	
DIODE(S)			
D101	MA165	DIODE	
D202	MA4110MTA	DIODE	
D204	MA165	DIODE	

Ref. No.	Part No.	Part Name & Description	Remarks	Ref. No.	Part No.	Part Name & Description	Remarks
D206	MA165	DIODE		VR502	EVJ01CF02G15	V. R. BALANCE	
D301	MA165	DIODE		VR971	EVQWQ102224B	V. R. TUNING	
D351, 352	MA165	DIODE		VR1001	EVJ01CF02G15	V. R. INPUT BALANCE	
D353	1SS291TA	DIODE				THERMISTOR (S)	
D354, 355	MA165	DIODE		TH2001	ERTD2ZHL103T	THERMISTOR	
D357-363	MA165	DIODE				COMPONENT COMBINATION (S)	
D366	MA700	DIODE		Z201	RLA2Z001-T	COIL	
D553	LN846RP	DIODE		Z202	SL17Z101-T	COMPONENT COMBINATION	
D601	MA165	DIODE		Z351, 352	EXFP12331MF	COMPONENT COMBINATION	
D651	MA165	DIODE		Z353	EXBF9E473J	COMPONENT COMBINATION	
D652	MA4068M	DIODE		Z354	EXBF9E103J	COMPONENT COMBINATION	
D701-704	P300DLF	DIODE	△	Z355	EXBF5E104J	COMPONENT COMBINATION	
D705, 706	MA4062MTA	DIODE		Z356	EXBF9E104J	COMPONENT COMBINATION	
D709	MA4360MTA	DIODE		Z891	A1QH3027HO	REMOTE CONT. SENSER	
D710	MA29WA	DIODE	△	Z901	EXFP12331MF	COMPONENT COMBINATION	
D711	MA4160-L	DIODE		Z902	EXBF8E473J	COMPONENT COMBINATION	
D712	MA4120	DIODE		Z903	EXBF5E103J	COMPONENT COMBINATION	
D751-754	SVDS5688GT3	DIODE	△	Z904	EXBF8E103J	COMPONENT COMBINATION	
D755	MA165	DIODE		Z905	EXBF5E103J	COMPONENT COMBINATION	
D757	MA4068M	DIODE		Z2002, 2003	EXBF6E824J	COMPONENT COMBINATION	
D891	MA165	DIODE				COIL (S)	
D892	LN846RP	DIODE		L101	RLQZPR47KT-Y	COIL	
D893	MA29WA	DIODE		L102	RLQZP1R2KT-Y	COIL	
D902-906	MA165	DIODE		L203, 204	ELEPK1ROMA	COIL	
D907	1SS291TA	DIODE		L351	ELEPK101KA	COIL	
D908-911	MA165	DIODE		L601, 602	SLQY07G-40	COIL	
D912	MA4056MTA	DIODE		L851, 852	RLQZP1R0KT-Y	COIL	
D914-917	MA165	DIODE		L901, 902	ELEPK101KA	COIL	
D919	MA165	DIODE		L951-953	RLQZP4R7KT-Y	COIL	
D921, 922	MA165	DIODE		L1001	ELEPK101KA	COIL	
D951, 952	MA4062MTA	DIODE				TRANSFORMER (S)	
D954	MA4030MTA	DIODE		T201	RLI4B002-Z	TRANSFORMER	
D955	MA165	DIODE		T202	RLI4B003-Z	TRANSFORMER	
D957-960	MA165	DIODE		T701	RTP1P5C007-V	POWER TRANSFORMER	△
D961	MA4056MTA	DIODE		T751	SLT5H2	TRANSFORMER	
D971	MA165	DIODE				FILTER (S)	
D972-974	LN031527PH	L. E. D. BLOCK		CF201, 202	RLFETNGM02LA	RED (10. 700MHz)	
D1001	MA4120	DIODE		CF201, 202	RLFETNGM02LB	BLUE (10. 675MHz)	
D1002-1005	MA165	DIODE		CF201, 202	RLFETNGM02LC	ORANGE (10. 725MHz)	
D1101-1104	GP15GLF	DIODE	△	CF351	EFOGC4004A4	CERAMIC FILTER	
D2001, 2002	MA4075HTA	DIODE		CF901	EFOGC4004A4	CERAMIC FILTER	
D2003	MA700	DIODE					
D2005, 2006	MA4030MTA	DIODE					
D2007, 2008	MA4043M	DIODE					
D2025-2028	MA165	DIODE					
D2029, 2030	MA4082MTA	DIODE					
		VARIABLE RESISTOR (S)					
VR301	EVNDXAA00B53	V. R. MPX VCO ADJ.					
VR351-354	EVQWQ2F1524B	V. R. P. EQ					
VR501	EUWMJCF25B15	V. R. MAIN VOLUME					

Ref. No.	Part No.	Part Name & Description	Remarks	Ref. No.	Part No.	Part Name & Description	Remarks
		OSCILLATOR(S)		S933	EVQ21405R	SW, TUNING MODE	
X101	SVQ49U722-S	OSCILLATOR				CONNECTOR(S) & SOCKET(S)	
X1001	EF0GC3004T4	OSCILLATOR					
		DISPLAY TUBE		CN201	RJT057W007	CONNECTOR(7P)	
FL901	RSL0055-F	DISPLAY TUBE		CN201A	RJU057W007	SOCKET(7P)	
		FUSE(S)		CN202	RJT057W007	CONNECTOR(7P)	
F1	XBA1F50NU14	FUSE	△	CN202A	RJU057W007	SOCKET(7P)	
F2, 3	XBA1F25NU14	FUSE	△	CN351, 352	SJT30648BB1	CONNECTOR(6P)	
		SWITCH(ES)		CN402	RJT003K006M1	CONNECTOR(6P)	
S351	EVQ21405R	SW, SLOPE(Q)		CN402A	RJU003K006M1	SOCKET(6P)	
S355	EVQ21405R	SW, FIXED PRESET		CN501	RJT003K006M1	CONNECTOR(6P)	
S356	EVQ21405R	SW, MANUAL PRESET 1		CN502	RJT057W004	CONNECTOR(4P)	
S357	EVQ21405R	SW, MANUAL PRESET 2		CN503	RJT003K006M1	CONNECTOR(6P)	
S358	EVQ21405R	SW, MANUAL PRESET 3		CN504	RJT057W004	CONNECTOR(4P)	
S359	EVQ21405R	SW, P. EQ MEMORY		CN601	RJS1A1705	CONNECTOR(5P)	
S360	EVQ21405R	SW, DISPLAY MODE		CN604	RJS1A1703	CONNECTOR(3P)	
S361	EVQ21405R	SW, P. EQ ON/OFF		CN651	SJT3213	CONNECTOR(2P)	
S362	EVQ21405R	SW, FINE ON/OFF		CN751	SJS305-1	CONNECTOR(3P)	
S363	EVQ21405R	SW, DOLBY ON/OFF		CN901	RJT003K008M1	CONNECTOR(8P)	
S364	EVQ21405R	SW, REAR LEVEL DOWN		CN901A	RJU003K008M1	SOCKET(8P)	
S365	EVQ21405R	SW, REAR LEVEL UP		CN902	RJT003K008M1	CONNECTOR(8P)	
S601	SSH2137	SW, SPEAKERS		CN902A	RJU003K008M1	SOCKET(8P)	
S701	SSH1238	SW, POWER	△	CN903	RJT003K008M1	CONNECTOR(8P)	
S901	EVQ21405R	SW, PRESET TUNING 1		CN903A	RJU003K008M1	SOCKET(8P)	
S902	EVQ21405R	SW, PRESET TUNING 2		CN904	RJT003K008M1	CONNECTOR(8P)	
S903	EVQ21405R	SW, PRESET TUNING 3		CN904A	RJU003K008M1	SOCKET(8P)	
S904	EVQ21405R	SW, PRESET TUNING 4		CN905	RJT003K008M1	CONNECTOR(8P)	
S905	EVQ21405R	SW, PRESET TUNING 5		CN905A	RJU003K008M1	SOCKET(8P)	
S906	EVQ21405R	SW, PRESET TUNING 6		CN906, 907	SJT30648BB1	CONNECTOR(6P)	
S907	EVQ21405R	SW, PRESET TUNING 7		CN908	SJT30549BB1	CONNECTOR(5P)	
S908	EVQ21405R	SW, PRESET TUNING 8		CN910	RJT003K008M1	CONNECTOR(8P)	
S909	EVQ21405R	SW, PRESET TUNING 9		CN910A	RJU003K008M1	SOCKET(8P)	
S910	EVQ21405R	SW, PRESET TUNING 0		CN1001	RJT057W007	CONNECTOR(7P)	
S911	EVQ21405R	SW, MEMORY SCAN		CN1001A	RJU057W007	SOCKET(7P)	
S912	EVQ21405R	SW, FM MODE		CN1002	RJT057W007	CONNECTOR(7P)	
S913	EVQ21405R	SW, FM		CN1002A	RJU057W007	SOCKET(7P)	
S914	EVQ21405R	SW, AM		CN2001	RJT003K010M1	CONNECTOR(10P)	
S917	EVQ21405R	SW, MEMORY		CN2001A	RJU003K010M1	SOCKET(10P)	
S918	EVQ21405R	SW, LOUDNESS		CN2002	RJT003K008M1	CONNECTOR(8P)	
S927	EVQ21405R	SW, PHONO		CN2002A	RJU003K008M1	SOCKET(8P)	
S928	EVQ21405R	SW, TUNER		CN2003	RJT057W004	CONNECTOR(4P)	
S929	EVQ21405R	SW, CD		CN2003A	RJU057W004	SOCKET(4P)	
S930	EVQ21405R	SW, VCR2		CN2004	RJT057W004	CONNECTOR(4P)	
S931	EVQ21405R	SW, VCR1		CN2004A	RJU057W004	SOCKET(4P)	
S932	EVQ21405R	SW, TAPE		CN353-1	RJS1A1704	SOCKET(4P)	
				CN353-2	RJS1A1705	SOCKET(5P)	
				CN351A	SJS50681BB	SOCKET(6P)	
				CN352A	SJS50681BB	SOCKET(6P)	
				CN401A	SJT3213	SOCKET(2P)	
				CN501A	RJU003K006M1	SOCKET(6P)	
				CN502A	RJU057W004	SOCKET(4P)	

Ref. No.	Part No.	Part Name & Description	Remarks	Ref. No.	Part No.	Part Name & Description	Remarks
CN503A	RJU003K006M1	SOCKET (6P)					
CN504A	RJU057W004	SOCKET (4P)					
CN602A	RJS1A1704	SOCKET (4P)					
CN701A	RJS1A1704	SOCKET (4P)					
CN702A	RJS1A1703	CONNECTOR (3P)					
CN703A	RJS1A1703	CONNECTOR (3P)					
CN705A	SJT3213	SOCKET (2P)					
CN906A	SJS50681BB	SOCKET (6P)					
CN907A	SJS50681BB	SOCKET (6P)					
CN908A	SJS50581BB	SOCKET (5P)					
CN401B	SJT3213	SOCKET (2P)					
CN602B	RJS1A1704	SOCKET (4P)					
CN701B	RJS1A1704	SOCKET (4P)					
CN702B	RJS1A1703	CONNECTOR (3P)					
CN703B	RJS1A1703	CONNECTOR (3P)					
CN701C	RJS1A1704	SOCKET (4P)					
CN703C	RJS1A1703	CONNECTOR (3P)					
CN701D	RJS1A1704	SOCKET (4P)					
CN703D	RJS1A1703	CONNECTOR (3P)					
		SHIELD PART (S)					
E401	SNE1004-1	GND PLATE					
E404, 405	SME103-6	P. C. B. HOLDER					
E504, 505	RSC0125	SHIELD PLATE					
E701-706	RJR0011	FUSE HOLDER					
E951	RSC0126	SHIELD PLATE					
E2001	RSC0127	SHIELD PLATE					
		RELAY (S)					
RL601	SSY134	RELAY					
RL751	RSY0005-1C	RELAY	△				
		FRONT END PACK ASS'Y					
TN101	RAL0006	FM FRONT END					
		JACK (S)					
JK101	RJH4405	JACK, ANTENNA					
JK401	SJF3069N	JACK, PHONO/CD					
JK402	SJF3069N	JACK, VCR1					
JK403	SJF3069N	JACK, TAPE					
JK404	SJF3069N	JACK, PRE OUT /MAIN IN					
JK405	SJFK5-1	JACK, VCR2 INPUT					
JK406	SJFD7-4	JACK, VIDEO OUT					
JK601-603	RJR0054	JACK, SPEAKERS					
JK791, 792	SJS9233B	JACK, AC OUTLET	△				
JK793	SJS9234B	JACK, AC INLET	△				
JK891	RJJ33TR01	JACK, REMOTE CONTROL OUT					
HP601	SJJ146B	JACK, HEADPHONES					

RESISTORS & CAPACITORS

Notes : * Capacity value are in microfarads (μF) unless specified otherwise, P=Pico-farads (pF) F=Farads (F)
 * Resistance values are in ohms, unless specified otherwise, 1K=1,000(OHM) , 1M=1,000k(OHM)

Ref. No.	Part No.	Values & Remarks	Ref. No.	Part No.	Values & Remarks	Ref. No.	Part No.	Values & Remarks
		RESISTORS	R309	ERDS2TJ334	1/4W 330K	R521	ERDS2TJ104	1/4W 100K
			R311	ERDS2TJ102	1/4W 1K	R522	ERDS2TJ103	1/4W 10K
			R312	ERDS2TJ153	1/4W 15K	R522A	ERDS2TJ153	1/4W 15K
R101, 102	ERDS2TJ103	1/4W 10K	R313, 314	ERDS2TJ473	1/4W 47K	R523, 524	ERDS2TJ221	1/4W 220
R104	ERDS2TJ102	1/4W 1K	R315, 316	ERDS2TJ103	1/4W 10K	R525, 526	ERDS2TJ102	1/4W 1K
R105	ERDS2TJ561	1/4W 560	R317	ERDS2TJ473	1/4W 47K	R527	ERDS2TJ394	1/4W 390K
R106	ERDS2TJ562	1/4W 5.6K	R351	ERDS2TJ272T	1/4W 2.7K	R528	ERDS2TJ104	1/4W 100K
R107	ERDS2TJ103	1/4W 10K	R352	ERDS2TJ105T	1/4W 1M	R529	ERDS2TJ222	1/4W 2.2K
R108	ERDS2TJ151	1/4W 150	R353	ERDS2TJ104	1/4W 100K	R531, 532	ERDS2TJ153	1/4W 15K
R201	ERDS2TJ332	1/4W 3.3K	R354	ERDS2TJ103	1/4W 10K	R567	ERDS2TJ391	1/4W 390
R202	ERDS2TJ824	1/4W 820K	R355	ERDS2TJ473	1/4W 47K	R601, 602	ERDS2TJ102	1/4W 1K
R203	ERDS2TJ122	1/4W 1.2K	R356	ERDS2TJ102	1/4W 1K	R603, 604	ERDS2TJ563	1/4W 56K
R204	ERDS2TJ824	1/4W 820K	R357, 358	ERDS2TJ103	1/4W 10K	R605, 606	ERDS2TJ182	1/4W 1.8K
R205	ERDS2TJ391	1/4W 390	R359	ERDS2TJ681	1/4W 680	R607, 608	ERDS2TJ563	1/4W 56K
R206	ERDS2TJ561	1/4W 560	R360-362	ERDS2TJ332	1/4W 3.3K	R609, 610	ERDS2TJ470	1/4W 47
R207	ERDS2TJ822	1/4W 8.2K	R367-370	ERDS2TJ331	1/4W 330	R611, 612	ERDS1FVJ100T	1/2W 10 Δ
R208	ERDS2TJ102	1/4W 1K	R371-375	ERDS2TJ104	1/4W 100K	R613	ERDS2TJ223	1/4W 22K
R209	ERDS2TJ471	1/4W 470	R378-385	ERDS2TJ102	1/4W 1K	R614	ERD25FJ470	1/4W 47 Δ
R210	ERDS2TJ332	1/4W 3.3K	R391-394	ERDS2TJ562	1/4W 5.6K	R615	ERDS2TJ473	1/4W 47K Δ
R211	ERDS2TJ222	1/4W 2.2K	R396	ERDS2TJ473	1/4W 47K	R616-618	ERDS1FVJ561T	1/2W 560 Δ
R212	ERDS2TJ153	1/4W 15K	R401, 402	ERDS2TJ332	1/4W 3.3K	R619, 620	ERG2ANJP331S	2W 330
R213	ERDS2TJ104	1/4W 100K	R403, 404	ERDS2TJ822	1/4W 8.2K	R621, 622	ERDS2TJ222	1/4W 2.2K
R214	ERDS2TJ824	1/4W 820K	R405, 406	ERDS2TJ470	1/4W 47	R623	ERDS2TJ684	1/4W 680K
R215	ERDS2TJ822	1/4W 8.2K	R407, 408	ERDS2TJ473	1/4W 47K	R624	ERDS2TJ103	1/4W 10K
R216	ERDS2TJ563	1/4W 56K	R411, 412	ERDS2TJ104	1/4W 100K	R627	ERDS2TJ154	1/4W 150K
R217	ERDS2TJ223	1/4W 22K	R413, 414	ERDS2TJ102	1/4W 1K	R628	ERDS2TJ684	1/4W 680K
R218	ERDS2TJ123	1/4W 12K	R417, 418	ERDS2TJ104	1/4W 100K	R651-654	ERDS2TJ223	1/4W 22K
R219	ERDS2TJ562	1/4W 5.6K	R419, 420	ERDS2TJ222	1/4W 2.2K	R655	ERDS2TJ392T	1/4W 3.9K
R220	ERDS2TJ103	1/4W 10K	R421	ERDS2TJ332	1/4W 3.3K	R656, 657	ERDS2TJ103	1/4W 10K
R221	ERDS2TJ104	1/4W 100K	R427	ERDS2TJ104	1/4W 100K	R658	ERDS2TJ223	1/4W 22K
R222	ERDS2TJ473	1/4W 47K	R451, 452	ERDS2TJ821	1/4W 820	R659-661	ERDS1FVJ220T	1/2W 22 Δ
R223	ERDS2TJ154	1/4W 150K	R453, 454	ERDS2TJ224T	1/4W 220K	R662	ERDS2TJ104	1/4W 100K
R224	ERDS2TJ223	1/4W 22K	R455, 456	ERDS2TJ563	1/4W 56K	R701	ERDS1FVJ332T	1/2W 3.3K Δ
R227	ERDS2TJ104	1/4W 100K	R457, 458	ERDS2TJ271	1/4W 270	R702	ERDS2TJ122	1/4W 1.2K Δ
R228	ERDS2TJ123	1/4W 12K	R459, 460	ERDS2TJ680T	1/4W 68	R703	ERDS2TJ272T	1/4W 2.7K
R229	ERDS2TJ102	1/4W 1K	R461, 462	ERDS2TJ184T	1/4W 180K	R704	ERDS2TJ222	1/4W 2.2K
R230	ERDS2TJ104	1/4W 100K	R463, 464	ERDS2TJ123	1/4W 12K	R705	ERDS2TJ272T	1/4W 2.7K
R231	ERDS2TJ471	1/4W 470	R465, 466	ERDS2TJ563	1/4W 56K	R706, 707	ERDS2TJ1R2	1/4W 1.2
R232	ERDS2TJ122	1/4W 1.2K	R467, 468	ERDS2TJ102	1/4W 1K	R708, 709	ERDS1FVJ180T	1/2W 18 Δ
R233	ERDS2TJ684	1/4W 680K	R501, 502	ERDS2TJ222	1/4W 2.2K	R710	ERDS2TJ272T	1/4W 2.7K
R234	ERDS2TJ103	1/4W 10K	R503, 504	ERDS2TJ103	1/4W 10K	R711	ERDS1FVJ2R2T	1/2W 2.2 Δ
R235	ERDS2TJ471	1/4W 470	R505, 506	ERDS2TJ104	1/4W 100K	R713	ERDS2TJ183T	1/4W 18K Δ
R237	ERDS2TJ221	1/4W 220	R507, 508	ERDS2TJ562	1/4W 5.6K	R715	ERDS2TJ101	1/4W 100 Δ
R247	ERDS2TJ103	1/4W 10K	R509, 510	ERDS2TJ563	1/4W 56K	R716	ERDS2TJ222	1/4W 2.2K
R301	ERDS2TJ393	1/4W 39K	R511	ERDS2TJ103	1/4W 10K	R717	ERD25FVJ150T	1/4W 15 Δ
R302	ERDS2TJ151	1/4W 150	R513, 514	ERDS2TJ393	1/4W 39K	R718, 719	ERDS2TJ1R8T	1/4W 1.8
R303, 304	ERDS2TJ223	1/4W 22K	R515, 516	ERDS2TJ222	1/4W 2.2K	R753, 754	ERDS2TJ472	1/4W 4.7K
R305, 306	ERDS2TJ272T	1/4W 2.7K	R517, 518	ERDS2TJ102	1/4W 1K	R755	ERDS2TJ102	1/4W 1K
R307, 308	ERDS2TJ104	1/4W 100K	R520	ERDS2TJ394	1/4W 390K	R771, 772	ERDS1FVJ2R2T	1/2W 2.2 Δ

Ref. No.	Part No.	Values & Remarks	Ref. No.	Part No.	Values & Remarks	Ref. No.	Part No.	Values & Remarks
R773, 774	ERD2FCVJ4R7T	1/4W 4.7 Δ	R1013	ERDS2TJ101	1/4W 100	R2033, 2034	ERDS2TJ123	1/4W 12K
R777, 778	ERD2FCVJ8R2T	1/4W 8.2 Δ	R1014	ERDS2TJ122	1/4W 1.2K	R2039	ERDS2TJ332	1/4W 3.3K
R779	ERDS1FVJ3R9T	1/2W 3.9 Δ	R1015, 1016	ERDS2TJ473	1/4W 47K	R2041	ERDS2TJ122	1/4W 1.2K
R780	ERDS1FVJ4R7T	1/2W 4.7 Δ	R1017	ERDS2TJ274	1/4W 270K	R2097, 2098	ERDS2TJ561	1/4W 560
R791	ERC12ZGK335	1/2W 3.3M Δ	R1018	ERDS2TJ154	1/4W 150K	R2099	ERDS2TJ222	1/4W 2.2K
R851	ERDS1FVJ2R2T	1/2W 2.2 Δ	R1019	ERDS2TJ332	1/4W 3.3K	R2100	ERDS2TJ824	1/4W 820K
R891	ERDS2TJ102	1/4W 1K	R1020	ERDS2TJ181T	1/4W 180	R2101	ERDS2TJ684	1/4W 680K
R894	ERDS2TJ102	1/4W 1K	R1021, 1022	ERDS2TJ223	1/4W 22K	R2102, 2103	ERDS2TJ183T	1/4W 18K
R895	ERDS2TJ103	1/4W 10K	R1023	ERDS2TJ103	1/4W 10K	R2107	ERDS2TJ392T	1/4W 3.9K
R901	ERDS2TJ152	1/4W 1.5K	R1024-1026	ERDS2TJ474	1/4W 470K	R2108, 2109	ERDS2TJ332	1/4W 3.3K
R902	ERDS2TJ105T	1/4W 1M	R1027-1029	ERDS2TJ332	1/4W 3.3K	R2112	ERDS2TJ473	1/4W 47K
R903	ERDS2TJ563	1/4W 56K	R1030	ERDS2TJ333	1/4W 33K	R2114	ERDS2TJ103	1/4W 10K
R904	ERDS2TJ123	1/4W 12K	R1031	ERDS2TJ105T	1/4W 1M	R2135	ERDS2TJ272T	1/4W 2.7K
R905	ERDS2TJ103	1/4W 10K	R1032	ERDS2TJ103	1/4W 10K	R2136	ERDS2TJ103	1/4W 10K
R906	ERDS2TJ334	1/4W 330K	R1033	ERDS2TJ222	1/4W 2.2K	R2137	ERDS2TJ392T	1/4W 3.9K
R907	ERDS2TJ681	1/4W 680	R1034	ERDS2TJ392T	1/4W 3.9K	R2138	ERDS2TJ104	1/4W 100K
R910	ERDS2TJ122	1/4W 1.2K	R1035	ERDS2TJ103	1/4W 10K	R2139	ERDS2TJ183T	1/4W 18K
R913, 914	ERDS2TJ101	1/4W 100	R1036	ERDS2EJ820	1/4W 82	R2154	ERDS2TJ273	1/4W 27K
R915	ERDS2TJ331	1/4W 330	R1049	ERDS2TJ102	1/4W 1K	R2155	ERDS2TJ824	1/4W 820K
R919, 920	ERDS2TJ122	1/4W 1.2K	R1101, 1102	ERDS2TJ222	1/4W 2.2K	R2161, 2162	ERDS2TJ821	1/4W 820
R921	ERDS2TJ103	1/4W 10K	R1103, 1104	ERDS2TJ563	1/4W 56K	R2167	ERDS2TJ823T	1/4W 82K
R922	ERDS2TJ224T	1/4W 220K	R1107, 1108	ERDS2TJ563	1/4W 56K	R2170	ERDS2TJ153	1/4W 15K
R923-925	ERDS2TJ331	1/4W 330	R1109, 1110	ERDS2TJ102	1/4W 1K	R2173, 2174	ERDS2TJ394	1/4W 390K
R946	ERDS2TJ222	1/4W 2.2K	R1111	ERDS2TJ684	1/4W 680K	R2179	ERDS2TJ4R7T	1/4W 4.7
R947	ERDS2TJ103	1/4W 10K	R1113	ERDS2TJ564	1/4W 560K	R2181-2184	ERDS2TJ272T	1/4W 2.7K
R948	ERDS2TJ221	1/4W 220	R1114	ERDS2TJ154	1/4W 150K	R2185, 2186	ERDS2TJ332	1/4W 3.3K
R949	ERDS2TJ472	1/4W 4.7K	R1115, 1116	ERD25FVJ4R7T	1/4W 4.7 Δ	R2187, 2188	ERDS2TJ471	1/4W 470
R951-954	ERDS2TJ562	1/4W 5.6K	R1117	ERDS2TJ222	1/4W 2.2K	R2189, 2190	ERDS2TJ102	1/4W 1K
R955	ERDS2TJ152	1/4W 1.5K	R1118	ERDS2TJ104	1/4W 100K	R2203	ERDS2TJ103	1/4W 10K
R956	ERDS2TJ474	1/4W 470K	R1120	ERDS2TJ824	1/4W 820K	R2204	ERDS2TJ473	1/4W 47K
R957	ERDS2TJ683	1/4W 68K	R1121	ERDS2TJ104	1/4W 100K	R2205	ERDS2TJ394	1/4W 390K
R958, 959	ERDS1FVJ331T	1/2W 330 Δ	R1122	ERDS2TJ102	1/4W 1K	R2208	ERDS2TJ102	1/4W 1K
R960	ERDS2TJ152	1/4W 1.5K	R1123	ERD25FJ470	1/4W 47 Δ	R2209	ERDS2TJ104	1/4W 100K
R964	ERDS2TJ224T	1/4W 220K	R1124	ERDS2TJ103	1/4W 10K	R2211-2214	ERDS2TJ221	1/4W 220
R965	ERDS2TJ104	1/4W 100K	R1125	ERDS2TJ222	1/4W 2.2K	R2215, 2216	ERDS2TJ391	1/4W 390
R966	ERDS2TJ332	1/4W 3.3K	R1126	ERDS2TJ103	1/4W 10K			
R967	ERDS2TJ102	1/4W 1K	R1127	ERD25FJ470	1/4W 47 Δ			JUMPER RESISTOR
R968	ERDS2TJ273	1/4W 27K	R1128	ERD25FJ470	1/4W 47 Δ			
R969	ERDS2TJ103	1/4W 10K	R2001, 2002	ERDS2TJ122	1/4W 1.2K	RJ1	ERJ6GEYOR00V	CHIP JUMPER
R971	ERDS2TJ331	1/4W 330	R2003, 2004	ERDS2TJ562	1/4W 5.6K			CAPACITORS
R972, 973	ERDS2TJ151	1/4W 150	R2005, 2006	ERDS2TJ122	1/4W 1.2K			
R976, 977	ERDS2TJ103	1/4W 10K	R2007, 2008	ERDS2TJ562	1/4W 5.6K			
R978-980	ERDS2TJ102	1/4W 1K	R2009, 2010	ERDS2TJ104	1/4W 100K			
R981, 982	ERDS2TJ473	1/4W 47K	R2011, 2012	ERDS2TJ273	1/4W 27K	C101, 102	ECBT1H150JC5	50V 15P
R983, 984	ERDS2TJ562	1/4W 5.6K	R2013, 2014	ERDS2TJ473	1/4W 47K	C103	ECBT1H102KB5	50V 1000P
R985, 986	ERDS2TJ824	1/4W 820K	R2015, 2016	ERDS2TJ223	1/4W 22K	C104	ECBT1H181KB5	50V 180P
R987, 988	ERDS2TJ224T	1/4W 220K	R2017, 2018	ERDS2TJ123	1/4W 12K	C105	ECEAJU221	6.3V 220U
R991	ERDS2TJ104	1/4W 100K	R2019, 2020	ERDS2TJ563	1/4W 56K	C106	ECKR1H103ZF5	50V 0.01U
R1001-1004	ERDS2TJ183T	1/4W 18K	R2021-2024	ERDS2TJ223	1/4W 22K	C107	ECKT1H223ZF	50V 0.022U
R1005-1010	ERDS2TJ153	1/4W 15K	R2025, 2026	ERDS2TJ103	1/4W 10K	C108	ECEA25M4R7R	25V 4.7U
R1011	ERDS2TJ272T	1/4W 2.7K	R2027, 2028	ERDS2TJ683	1/4W 68K	C109	ECEA1CU330	16V 33U
R1012	ERDS2TJ471	1/4W 470	R2029, 2030	ERDS2TJ333	1/4W 33K	C110, 111	ECBT1H102KB5	50V 1000P
			R2031, 2032	ERDS2TJ821	1/4W 820	C201, 202	ECKR1H103ZF5	50V 0.01U

Ref. No.	Part No.	Values & Remarks	Ref. No.	Part No.	Values & Remarks	Ref. No.	Part No.	Values & Remarks
C204	ECBT1H470J5	50V 47P	C459, 460	ECFR1E682KR	25V 6800P	C919	ECEA1HK3R3	50V 3.3U
C205	ECKT1H223ZF	50V 0.022U	C461, 462	ECEA1VPS4R7	35V 4.7U	C922	ECKR1H331KB5	50V 330P
C206	ECBT1H150JC5	50V 15P	C463, 464	ECEA0JPS330	6.3V 33U	C924	ECKR1H103ZF5	50V 0.01U
C207	ECBT1C103MS5	16V 0.01U	C503, 504	ECFR1E333KR	25V 0.033U	C951	ECEA1CU470	16V 47U
C208	ECEA0JU101B	6.3V 100U	C505, 506	ECEA1VPS4R7	35V 4.7U	C952	ECBT1H102KB5	50V 1000P
C209	ECEA1CK100B	16V 10U	C509, 510	ECEA1CPS220	16V 22U	C953	ECQP1102JZ3	100V 1000P
C210-212	ECKT1H223ZF	50V 0.022U	C511, 512	ECBT1H220JC5	50V 22P	C954	ECBT1H102KB5	50V 1000P
C213	ECBT1H101KB5	50V 100P	C513, 514	ECEA1VPS4R7	35V 4.7U	C955	ECEA1CU470	16V 47U
C214	ECEA1CK100B	16V 10U	C517	ECKR1H103ZF5	50V 0.01U	C956	ECBT1H102KB5	50V 1000P
C215	ECKR1H103ZF5	50V 0.01U	C520, 521	ECKR1H103ZF5	50V 0.01U	C957	ECEA1EK3R3B	25V 3.3U
C216	ECEA1CK100B	16V 10U	C601, 602	ECEA1VPS4R7	35V 4.7U	C958	ECEA1CK100B	16V 10U
C217	ECEA1HK2R2B	50V 2.2U	C603, 604	ECQP1271JZ	50V 270P	C959	ECBT1H8R2JC5	50V 8.2P
C220	ECEA1CK100B	16V 10U	C605, 606	ECEA1CPS220	16V 22U	C960	ECEA1EK3R3B	25V 3.3U
C221	ECFR1E183KR	25V 0.018U	C607, 608	ECCR1H100K5	50V 10P	C971, 972	ECBT1H101KB5	50V 100P
C222	ECQM1H473JZ	50V 0.047U	C609, 610	ECCD1H151K	50V 150P	C973	ECBT1H331KB5	50V 330P
C225	ECBT1H180JC5	50V 18P	C611, 612	ECKT1H223ZF	50V 0.022U	C1001, 1002	ECKR1H103ZF5	50V 0.01U
C226	ECKR1H103ZF5	50V 0.01U	C613	ECEA1VU470	35V 47U	C1003	ECEA1HU010	50V 1U
C227	ECEA1CK100B	16V 10U	C614	ECEA1HU330	50V 33U	C1004	ECQM1H332KV3	50V 3300P
C228	ECBT1H100JC5	50V 10P	C615	ECEA2AU100	100V 10U	C1005	ECBT1H561KB5	50V 560P
C301	ECEA1CU101	16V 100U	C616	ECEA2AN2R2SB	100V 2.2U	C1006	ECQM1H104JZ	50V 0.1U
C302	ECEA1HKR47	50V 0.47U	C617, 618	ECQM1H681KF3	50V 680P	C1007	ECEA1CU470	16V 47U
C303	ECEA1HK010B	50V 1U	C651	ECEA1HK2R2B	50V 2.2U	C1008, 1009	ECFR1E104KR	25V 0.1U
C304-306	ECEA1HK3R3	50V 3.3U	C701, 702	ECES1JV822UZ	63V 8200U Δ	C1010	ECQM1H104JZ	50V 0.1U
C307, 308	ECFR1E273KR	25V 0.027U	C703	ECKR1H103ZF5	50V 0.01U Δ	C1011	ECQM1H332KV3	50V 3300P
C309	ECKT1H223ZF	50V 0.022U	C704	ECEA1VU101B	35V 100U Δ	C1012	ECBT1H561KB5	50V 560P
C310	ECFR1E473KR	25V 0.047U	C705	ECEA1CU101	16V 100U	C1013	ECEA1HU010	50V 1U
C311	ECQP1471JZ	50V 470P	C706	ECKR1H103ZF5	50V 0.01U	C1014	ECQM1H123JZ	50V 0.012U
C312	ECEA1VK4R7	35V 4.7U	C709	ECKR1H103ZF5	50V 0.01U Δ	C1015	ECFR1E104KR	25V 0.1U
C313, 314	ECBT1H181KB5	50V 180P	C710	ECKR1H103ZF5	50V 0.01U	C1016	ECEA0JU101B	6.3V 100U
C351	ECKR1H103ZF5	50V 0.01U	C711	ECEA1CU101	16V 100U	C1017	ECEA1CU100	16V 10U
C352	ECEA1HK010B	50V 1U	C712	ECEA1VU470	35V 47U Δ	C1018	ECQM1H472JZ	50V 4700P
C353	ECEA1HK3R3	50V 3.3U	C713	ECEA0JU101B	6.3V 100U	C1019	ECQM1H273KV3	50V 0.027U
C354, 355	ECEA0JU102	6.3V 1000U	C751	ECEA1CU102	16V 1000U	C1020	ECQM1H473JZ	50V 0.047U
C356	ECKR1H103ZF5	50V 0.01U	C752	ECEA1CU470	16V 47U	C1021	ECEA1CU100	16V 10U
C357	ECEA0JU102	6.3V 1000U	C753	ECKR1H103ZF5	50V 0.01U	C1022	ECQM1H104JZ	50V 0.1U
C358-360	ECEA1HK2R2B	50V 2.2U	C754	ECKR1H103ZF5	50V 0.01U Δ	C1023	ECQV1H334JZ3	50V 0.33U
C361	ECBT1H101KB5	50V 100P	C755	ECBT1H221KB5	50V 220P	C1024	ECEA1CU221	16V 220U
C362	ECEA0JU101B	6.3V 100U	C756	ECEA1CPS220	16V 22U	C1025	ECEA1CU470	16V 47U
C363	ECBT1E103ZF	25V 0.01U	C771	ECKR2H103ZU	500V 0.01U Δ	C1026	ECQM1H562JZ	50V 5600P
C401, 402	ECKR1H103ZF5	50V 0.01U	C791	ECKWNS103ZV	500V 0.01U Δ	C1027	ECEA1CU100	16V 10U
C407, 408	ECBT1H101KB5	50V 100P	C851, 852	ECEA0JU101B	6.3V 100U	C1028, 1029	ECEA1HU010	50V 1U
C409, 410	ECKR1H103ZF5	50V 0.01U	C853, 854	ECFR1E104KR	25V 0.1U	C1030-1032	ECEA1EU3R3	25V 3.3U
C411, 412	ECEA1CU470	16V 47U	C891	ECFR1E392KR	25V 3900P	C1033	ECEA1HU3R3	50V 3.3U
C415, 416	ECKR1H103ZF5	50V 0.01U	C901, 902	ECEA0JU102	6.3V 1000U	C1034, 1035	ECKR1H103ZF5	50V 0.01U
C417	ECBT1H101KB5	50V 100P	C903	ECEA1HK010B	50V 1U	C1036-1038	ECBT1H181KB5	50V 180P
C419	ECEA0JU101B	6.3V 100U	C905	ECKR1H331KB5	50V 330P	C1039	ECEA1CU100	16V 10U
C421, 422	ECEA1CPS220	16V 22U	C906	ECEA0JU102	6.3V 1000U	C1040	ECEA1CU470	16V 47U
C425	ECBT1H101KB5	50V 100P	C910	ECBT1E103ZF	25V 0.01U	C1041	ECEA0JU220B	6.3V 22U
C451, 452	ECEA1VPS4R7	35V 4.7U	C911-913	ECEA1HK3R3	50V 3.3U	C1101, 1102	ECEA1HU3R3	50V 3.3U
C453, 454	ECBT1H101KB5	50V 100P	C914	ECEA1VK100B	35V 10U	C1103, 1104	ECBA1H681KB5	50V 680P
C455, 456	ECBT1H102KB5	50V 1000P	C915	ECEA1VU101B	35V 100U	C1105, 1106	ECBT1H821KB5	50V 820P
C457, 458	ECFR1E223KR	25V 0.022U	C916	ECEA0JU102	6.3V 1000U	C1107, 1108	ECEA1HU220	50V 22U

■ PACKING

