

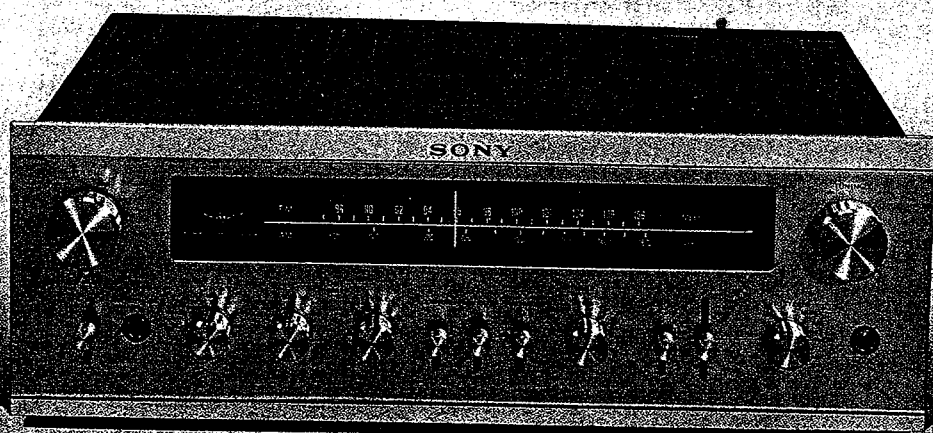

Set using ISO screws

STR-6065



SONY
SERVICE MANUAL

TABLE OF CONTENTS

	<i>Page</i>
SECTION 1	TECHNICAL DESCRIPTION
1-1.	Technical Specifications 1~2
1-2.	Detailed Circuit Analysis 2~12
1-3.	Level Diagram 10
1-4.	Block Diagram - Tuner Section - 11
1-5.	Block Diagram - Audio Section - 12
SECTION 2	DISASSEMBLY AND REPLACEMENT PROCEDURES
2-1.	Tools Required 13
2-2.	Hardware Identification Guide 13
2-3.	Top Cover and Bottom Plate Removal 13
2-4.	Front Panel Removal 13~14
2-5.	Dial-Cord Restringing 14~16
2-6.	Mechanical Dial Calibration 16
2-7.	Dial Scale Replacement 16
2-8.	Pilot-Lamp Replacement 16~17
2-9.	Tuning Meter Replacement 17
2-10.	Control and Switch Replacement 17~18
2-11.	Rear Panel Removal 18
2-12.	Replacement of Components Secured to the Rear Panel by Rivets 18~19
2-13.	Power Transistor Replacement 19
2-14.	Chassis Layout 20
SECTION 3	ALIGNMENT AND ADJUSTMENT PROCEDURES
3-1.	Fm I-f Strip Alignment 21~22
3-2.	Fm Discriminator Alignment 22~23
3-3.	Muting Adjustment 23
3-4.	Fm Frequency Coverage Alignment 23~24
3-5.	Fm Stereo Separation Adjustment 24~26
3-6.	A-m I-f Strip Alignment 27
3-7.	A-m Frequency Coverage and Tracking Adjustment 28~30
3-8.	Power-Amplifier Adjustment 30~31
SECTION 4	REPACKING 32
SECTION 5	DIAGRAMS
	Mounting Diagrams
	- Loudness Control Board - 33
	- Equalizer Board - 34
	- Fm Front End - 35
	- Fm I-f Board - 36~37
	- MPX Board - 38~39
	- A-m I-f Board - 40~41
	- Power Amplifier Board - 42~43
	- Power Supply Board - 44~45
	- Tone Control Board - 46
	Schematic Diagrams
	- Tuner Section - 47~48
	- Audio Section - 49~50
SECTION 6	EXPLODED VIEW 51~54
SECTION 7	ELECTRICAL PARTS LIST 55~60

SECTION 1

TECHNICAL DESCRIPTION

1-1. TECHNICAL SPECIFICATIONS

Technical specifications for the STR-6065 are given in Table 1-1.

TABLE 1-1. TECHNICAL SPECIFICATIONS

Fm Tuner Section		Audio Amplifier Section	
Antenna:	300 ohms balanced	IHF Dynamic power:	255 watts (4 Ω), both channels operating (constant power supply method) 220 watts (8 Ω), both channels operating (constant power supply method)
Tuning range:	87.5 to 108 MHz	Rated output: (RMS Power)	80 watts (4 Ω) per channel, both channels operating 70 watts (8 Ω) per channel, both channels operating 110 watts (4 Ω), each channel 80 watts (8 Ω), each channel
Sensitivity:	2.2 μ V (IHF usable sensitivity) 1.8 μ V (S/N 30 dB) 1.4 μ V (S/N 20 dB)	20 Hz ~ 20 kHz power:	50 watts (8 Ω) both channels operating
S/N ratio:	70 dB	Power band width:	15 Hz to 30 kHz, IHF
Capture ratio:	1.5 dB	Harmonic distortion:	less than 0.2% at 1 kHz at rated output less than 0.05% at 1W output
Selectivity:	80 dB	Frequency response:	PHONO : RIAA curve TAPE : 10 Hz to 60 kHz REC/PB : 10 Hz to 60 kHz
Image rejection:	75 dB	Input sensitivity * and impedance:	PHONO-1, -2 : 1.8 mV 47 k AUX-1, -2 : 140 mV 100 k TAPE : 140 mV 100 k REC/PB : 140 mV 100 k
I-f rejection:	90 dB	Signal output and output impedance:	REC OUT : 250 mV 10 k REC/PB : 30 mV 80 k CENTER CHANNEL OUT: 5V 1k
Spurious rejection:	100 dB	S/N ratio:	PHONO-1, -2 : greater than 70 dB (weighting network "B") TAPE AUX-1, -2 : greater than 90 dB (weighting network "A") REC/PB : greater than 90 dB (weighting network "A")
A-m suppression:	65 dB	Tone controls:	BASS : 10 dB at 100 Hz TREBLE : 10 dB at 100 Hz
Frequency response:	20 Hz to 15 kHz \pm 0.5 dB	Filter:	HIGH : 6 dB/oct. above 5 kHz
Separation:	38 dB at 400 Hz	Loudness:	50 Hz, +10 dB 10 kHz, +4 dB (with 30 dB attenuation)
Harmonic distortion:	Mono: 0.2%, IHF (400 Hz 100% Mod) Stereo: 0.5%, IHF (400 Hz 100% Mod)		
19 kHz, 38 kHz suppression:	60 dB		
Muting level:	less than 5 μ V		
A-m Tuner Section			
Antenna:	Built-in ferrite bar antenna with external antenna terminal		
Tuning range:	530 to 1,605 kHz		
Sensitivity:	48 dB/m, built-in antenna (S/N: 20 dB) 20 μ V, external antenna		
I-f rejection:	46 dB at 1,000 kHz		
Harmonic distortion:	0.8%		

	General	<i>Stage/Control</i>	<i>Function</i>
Power consumption:	Approx. 120 watts (USA) Approx. 240 watts (CSA) Approx. 250 watts (General Export Model)	AFC circuit D101, D102 C120	L104. An automatic frequency control circuit is incorporated in the oscillator circuit to eliminate frequency drift and precise tuning difficulty. The principle of afc operation is as follows: When the tuner is correctly tuned, the intermediate frequency is 10.7 MHz and no dc correction voltage is produced by the ratio detector as shown in the "S" curve response of Fig. 1-1. Thus the voltage applied to diode D101 is determined solely by the positive fixed reverse bias voltage supplied by zener diode D102.
Power requirement:	100, 117, 220, 240 volts ac (General Export Model) 117V only (USA, CANADA Model)		Now assume that the local oscillator frequency changes by $+\Delta f$. This means that the new intermediate frequency is $10.7 + \Delta f$. See Fig. 1-1. As the result a positive dc component is fed back to the anode of D101, decreasing the reverse voltage to it, and making D101's barrier capacitance increase. This decreases the local oscillator's frequency, since the series circuit composed of C120 and D101 is connected in parallel with the tank circuit of the local oscillator. Conversely, if the local oscillator frequency decreases a negative dc voltage is fed back to D101 increasing the local oscillator frequency.
Dimensions:	440 mm (width) \times 148 mm (height) \times 354.5 mm (depth) 17 ⁵ / ₁₆ " (width) \times 5 ¹³ / ₁₆ " (height) \times 13 ¹⁵ / ₁₆ " (depth)		
Net weight:	13.5 kg (29 lb 12 oz)		
Shipping weight:	17.5 kg (38 lb 9 oz)		

1-2. DETAILED CIRCUIT ANALYSIS

The following describes the function or operation of all stages and controls. The text sequence follows signal paths. Stages are listed by transistor reference designation at the left margin; major components are also listed in a similar manner. Refer to the block diagram on page 11 to 12 and the schematic diagram on page 47 to 50.

<i>Stage/Control</i>	<i>Function</i>	
Fm Front End		
Balun B901	This transformer matches 300-ohm twin lead to the fm front-end's input stage and thereby couples the receiver signal to the front-end.	C120
Passive rf circuit	A triple-tuned circuit is employed between the antenna and mixer transistor. This passive coupling circuit contains no active amplifiers, so it is perfectly linear and cannot produce distortion and overload components. Thus, the factors that contribute to spurious responses are eliminated ahead of the mixer.	Mixer Q101
Local oscillator Q102	Supplies heterodyning voltage to the mixer via L104. The circuit is a modified Hartley type with feedback applied to the emitter from the tap on	IFT101

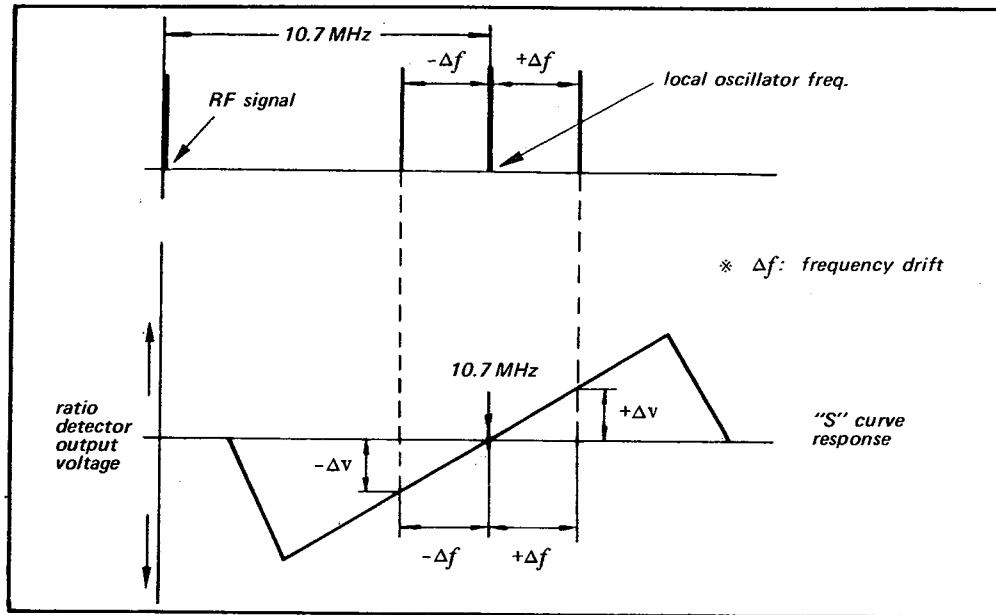

Fig. 1-1. Local oscillator's frequency drift and afc voltage relationship

Stage/Control	Function	Stage/Control	Function
I-f preamplifier Q103	The i-f signal coupled to the base of i-f preamplifier Q103 by the secondary winding of IFT101 is amplified to achieve a favorable signal-to-noise ratio before application to the filters in the i-f strip.	Diode limiters D201 to D206 D209, D210	Limiting is accomplished by diode pairs, connected in parallel and poled in opposite directions. The diodes conduct when the signal across them exceeds the barrier potential of about 0.6 volts in the forward direction. Thus the signal is limited in both directions to 1.2 volts peak-to-peak. The diodes provide symmetrical limiting.
I-f Amplifier		Ratio detector D207, D208	T201 and diodes D207 and D208 form a balanced ratio detector that transforms the frequency-modulated signal into an audio signal. Output appears across C216.
I-f amplifiers Q201 to Q205 CF201 to CF206	These i-f stages are basically RC coupled amplifiers (except Q205) that provide essentially flat response. The selectivity of this section is determined by three pairs of filters CF201, CF202, CF203, CF204, CF205 and CF206 in the interstage coupling path. Each of these filters is a two-section ceramic filter that operates in the "trapped-energy" mode. The filters provide extremely-sharp skirt selectivity and flat response inside the passband. Thus, these filters largely determine overall tuner selectivity.	Muting circuit Q207, Q208, Q209, Q210 D211 to D213	The i-f signal is extracted from limiter diodes D203 and D204 to drive the muting circuit. The extracted i-f signal is amplified by Q208 (FET) enough to drive voltage doubler D212 and D211 through tuned transformer T202.
I-f output Q206	Signal at the base of Q206 has had all amplitude variations removed by the preceding lim-		iters, and only selected signals have been passed by ceramic filters. Q206 provides power to drive the ratio detector.

*Stage/Control**Function*

D213 provides positive fixed bias for Q209 through D212 and D211. T202 determines the bandwidth necessary to control the muting circuit without generating interstation or detuning noise. The output of the voltage doubler is a positive dc voltage proportional to the carrier levels of weak rf signals. Q209 and Q210 form a switching circuit which is driven by the voltage doubler. Q209 is normally cut off, thus forcing Q210 into conduction.

The collector of Q210 is connected to the gate of FET Q207 through MUTING switch S7. FET Q207 acts as an electronic switch which is inserted between the ratio detector and MPX decoder, and is controlled by the gate voltage applied.

With the MUTING switch ON, fm signals of average strength keep Q209 saturated, thus cutting off Q210. This causes Q207 to conduct and maintain normal operation.

Weak stations and interstation noise can not produce sufficient dc voltage at the base of Q209 to keep it conducting. As a result, Q209 cuts off.

This saturates Q210 and cuts off Q207, accordingly, the audio output is muted. With the MUTING switch OFF, Q207 is kept conducting regardless of the strength of the fm signal by a positive bias voltage on its gate. RV201 adjusts the muting level.

Stereo-mono
automatic-
switching circuit
Q210, D409

The collector of Q210 is also connected to the output terminal of the MPX decoder's frequency doubler through diode D409.

This prevents noisy stereo reception by automatically switching the MPX decoder's operation into the monaural mode. This is needed because in fm stereo

*Stage/Control**Function*

broadcasting, the S/N ratio of a demodulated stereo signal degrades much more rapidly than that of a mono signal when the input signal strength decreases. As Q210 is forced into conduction by weak stations, the frequency doubler's output is effectively grounded, stopping the operation of the stereo demodulator. Thus, automatic switching of stereo to mono according to the input rf signal level is achieved.

TUNING meter
M901

Center-zero meter assures correct tuning by utilizing the ratio detector's characteristic.

As indicated in Fig. 1-1 no dc voltage is produced across connection of R243 and R244 and ground when the tuner is correctly tuned. Deflection on the meter indicates the amount of deviation from the carrier frequency received.

Note that the meter will indicate zero-reading when the tuner is not receiving any off-the-air signal.

R243, R244

SCA trap
L203, C220

The composite signal containing monaural information from 0 to 15 kHz, the 19 kHz pilot carrier, and the fm stereo signal at 38 kHz is fed to Q207 through trap L203-C220. This trap removes the unwanted SCA signal to the base of Q401 (the 19 kHz amplifier) through Q207.

MPX Decoder

19 kHz amplifier
Q401

This stage serves two functions. It extracts the 19 kHz pilot signal by means of a tuned circuit at its drain, and provides a low-impedance source of composite stereo signal (without pilot carrier) at its source. By using an FET, harmonics of the 19 kHz and 38 kHz components are reduced to a low level thereby causing less carrier leak or beat interference.

<i>Stage/Control</i>	<i>Function</i>	<i>Stage/Control</i>	<i>Function</i>
Frequency doubler D401, D402	Signals developed at the drain of Q401 are transformer coupled to a fullwave rectifier consisting of D401 and D402. The output of this rectifier is not filtered, resulting in two positive pulses for each input cycle. Thus, the 19 kHz pilot-carrier frequency is effectively doubled by D401 and D402. However, the wave form is not sinusoidal at the base of Q402.		operated in the stereo mode. In the monaural mode, diodes D405 and D408 are forward biased by supply voltage through R405, the stereo indicator lamp, R412, R414, and R413, so these diodes merely act as small resistances. Under this condition, the monaural signal is applied to both "L" and "R" audio amplifiers.
38 kHz amplifier Q402	The 38 kHz pulses produced by D401 and D402 are amplified by Q402. The tank circuit at the collector of Q402 is tuned to 38 kHz to restore these pulses to a sinusoidal waveform. This signal is transformer coupled to the bridge-type demodulator to supply sampling drive for the demodulator.	De-emphasis capacitors C902, C903 C422, C423	These capacitors provide the roll off at high audio frequencies necessary to compensate for pre-emphasis at the transmitter. S10 should be set to the proper time constant. Specified de-emphasis time constant is 75 micro-seconds in USA and CANADA, 50 micro-seconds in Europe.
STEREO lamp circuit Q403	The STEREO indicator lights when the FUNCTION switch is set to the FM-AUTO STEREO position and an fm stereo signal is received. The emitter of Q402 is connected to the base of Q403 (which is normally cut off). The circuit operates as follows: When a composite stereo signal is applied to the multiplex decoder, the 38 kHz pulses produced at the output of the frequency doubler yield a higher average current flow through Q402. This forces Q403 into conduction, lighting STEREO indicator lamp PL904.	Audio preamplifier Q404, Q405 Q406, Q407	Demodulated L and R signals are amplified by these stages to the level required at the input of the following low pass filter.
		Separation control RV401	The network that connects the emitters of Q404 and Q405 provides a form of negative feedback between left and right channels. Any residual "L" signal in the "R" channel (which is about 180° out of phase) is cancelled out by the "L" signal from the "L" channel. The same is true of residual "R" signal in the "L" channel. RV401 is therefore set for maximum separation.
		LPF401	Filters out the unwanted higher-order harmonics of 19 kHz and 38 kHz leakage to obtain clear audio.
Multiplex demodulator D405, D406, D407, D408	The demodulator circuit employs four diodes in a balanced-bridge arrangement. This system has the advantage of cancelling residual rf components (38 kHz signal, some 19 kHz signal, and higher-order harmonics of these frequencies.) "L" and "R" components are developed at each side of the bridge as the result of demodulation, when the receiver is	A-m Tuner Local oscillator Q305	This stage supplies injection voltage to the mixer via L904. In this oscillator circuit feedback is applied to the emitter of Q305 from low-impedance winding on oscillator coil L304.

<i>Stage/Control</i>	<i>Function</i>	<i>Stage/Control</i>	<i>Function</i>
Mixer Q301	Incoming rf signals and local-oscillator voltage are heterodyned in the base-emitter junction of Q301 to produce the 455-kHz output. FET Q302 couples the output of the mixer to IFT-301. This stage functions as the gain control element of the AGC system as will be explained later. IFT301 is a transformer tuned to 455 kHz. It develops the i-f signal, and provides a path to ground through bypass capacitor C307 for the other heterodyne products. The low-impedance output winding of IFT301 provides link coupling to i-f amplifier Q303.		to control its gain. The time constants of the agc filter components remove audio variations from the agc voltage.
I-f amplifier Q303	This stage is basically an RC-coupled amplifier. The selectivity of the stage is determined by a double ceramic filter (CF301) in the interstage-coupling path. This filter provides extremely sharp skirt selectivity inside the passband.	Preamplifier Section	
CF301		Equalizer amplifier Q501, Q502, Q503	This direct-coupled three stage amplifier amplifies the small signal provided by the phono cartridge to the level required at the input of the following tone-control amplifier.
I-f amplifier Q304	This circuit provides the power to drive diode detector D302.	Bias circuit R503, R510	Dc bias voltage for Q501 is extracted from R510 in the emitter circuit of Q503 and fed back to the base of Q501 through R503 and R504. This dc negative feedback technique provides stable operation during temperature changes.
Detector D302	The i-f signal from the secondary of IFT302 is rectified by diode D302. The i-f components of the output signal are filtered by C317, C318, and R320. The output appearing across R322, R323 is therefore clean audio.	Equalization circuit R512, R513, R514, R506, C506, C507	RIAA equalization is achieved by the negative-feedback loop containing R512, R513, R514, R506, C506 and C507. Be sure to use replacement components with the exact same values.
TUNING METER	The a-m i-f signal is extracted from secondary winding of IFT302 to drive TUNING METER M901. The extracted i-f signal is rectified by D303. The negative dc component at the anode of D303 is filtered by C313, R336, and fed to the TUNING METER.	Equalization circuit R515 (R565)	R515 (R565) in the output circuit prevents interaction between left and right channel-equalization when the MODE switch is set to L+R.
Agc circuit	The negative dc component at the anode of diode D302 is filtered by R325, C336, C335, R335, C322, R326, C323 and fed back to the gate of Q302	MODE switch S4	In the STEREO position of S4, left and right input signals are routed to their respective amplifiers. In the L+R position, the left and right signals are added and the sum is then fed to both amplifier channels. A rotary switch having two sections is used to obtain L+R signal even if the MONITOR switch is set to the TAPE position.
		VOLUME control RV601 (RV651)	The equalized phono signals and signals applied to the other input terminals are fed to the VOLUME control through the MONITOR and MODE switches. The level of the signal applied

<i>Stage/Control</i>	<i>Function</i>	<i>Stage/Control</i>	<i>Function</i>
	to the following tone-control amplifier is determined by the setting of RV601.		put is extracted from the collector circuit of Q701. This circuit has a various advantages in direct coupling system. One is high stability despite temperature variations and another is high input impedance without reducing the amplifier's gain. The ac output appears across load resistor R707 (R757) in the collector circuit. An emitter decoupling circuit is formed by the emitter-base resistance of Q702, C702 and R710 in the base circuit of Q702. This circuit forms a frequency-selective ac bypass circuit to reduce the amplifier's gain at very low frequencies. Common emitter-resistor R709 keeps the dc current flow constant in the Q701 and Q702, thus increasing dc stability.
LOUDNESS switch S5	This switch and R601, R602, C601, C602 compensate for the characteristics of the human ear which vary according to the loudness of the sound being heard. When this switch is set to ON and the VOLUME control is set for 30 dB attenuation, the overall frequency response is increased 10 dB at 50 Hz and 4 dB at 10 kHz with reference to the level at 1 kHz.		
Tone-control amplifier Q601, Q602 (Q651, Q652)	This direct-coupled two-stage amplifier has basically flat response, but it operates as a negative-feedback type tone-control circuit. The output generated at the collector circuit of Q602 is fed back to the emitter circuit of Q601 through the treble and bass tone-control network.	Bias power supply D701, D702	These diodes are forward biased by positive and negative power supply voltage through RV701 and RV751. They provide a stabilized voltage to bias transistor Q701 that is used to make the output terminal balance at zero dc through RV701.
TREBLE control RV603 (RV653)	Increases or decreases the amount of negative feedback voltage determined by the setting of RV603. It has a range of 10 dB at 10 kHz.	Ac balance adj. RV701 (RV751)	
BASS control RV604 (RV654)	Similar to the treble control except for filter components and frequency characteristics, however in this circuit the negative feedback voltage is determined by the setting of RV604. This has a range of 10 dB at 100 Hz.	Thermal compensation and noise suppressor D703	As all the stages are directly coupled, dc stability is required. The negative temperature coefficient of D703 provides thermal compensation for the following driver stage. It also acts as a noise suppressor to reduce the popping noise due to unbalanced current flow in the following stages when the power switch is turned off.
HIGH FILTER S6	The high-cutoff filter (R616 and C613) eliminates unwanted high-frequency components (5 kHz and higher) from the input signal when this switch is ON.	Driver Q703	Though this stage is a conventional flat amplifier, it determines the output voltage swings because the following stages are basically in the emitter-follower configuration. The ac load resistor for this stage is R716.
Power Amplifier Section			
Preamplifier Q701, Q702	Q701 and Q702 form a para-phase amplifier but signal out-		

<i>Stage/Control</i>	<i>Function</i>
Dc bias adj. (idling current) Q704, RV702	Q704 is forced to conduct and operates as a small resistance providing the necessary forward bias on the two cascaded emitter-followers. RV702 controls the base bias of Q704, determining the impedance between the emitter and collector of Q704, and thereby controls the dc bias voltage for the following complementary circuit.
Thermal compensator for dc bias D901	The negative temperature coefficient of D901 provides thermal compensation for the complementary and power transistor circuits. D901 is attached to the power transistor's heat sink to detect temperature increases in the power transistors.
Complementary circuit Q708, Q709	These transistors operate as emitter-followers to provide the current swings demanded of the output stages and also provide the necessary phase inversion. Phase inversion is performed by using PNP and NPN type transistors.
Power transistor Q901, Q902	The output transistors (Q901 and Q902) are connected directly to a power supply of about $\pm 50V$. Q902 supplies power to the load during the positive half cycle and Q901 operates during the negative half cycle. As all the stages are directly coupled and designed to obtain zero potential at the output terminal, the large coupling capacitor at the output (which may cause power loss or distortion at low frequencies) is eliminated.
Protection circuit	To protect overloaded power transistors from destruction, a new protection circuit is employed. In the event of a short circuit at the output terminals, the protection circuit holds the current in the power transistor low enough not to make it

Stage/Control *Function*

overheat and also limit the input drive signals.
Fig. 1-2 shows a partial schematic diagram detailing the protection circuit. With reference to this diagram, the protection circuit operates as follows:
Since the protection circuit is identical for positive going half cycles and negative going half cycles, only the positive going half cycle operation is described here. Q705 limits the positive-going half cycle of the drive voltage applied to the base of Q708 when power consumption at the Q902 collector exceeds the safety margin. Since power dissipation at the collector can be considered a function of collector voltage and current, the trigger signal for Q705 is taken from the collector and emitter. Base voltage is partly determined by the ratio of resistance of R722 and series resistance of R729, R738 and RL (load). Base voltage is also determined by the current flow in the R738 and the collector voltage of Q902. During normal operation, Q705 is cut off.

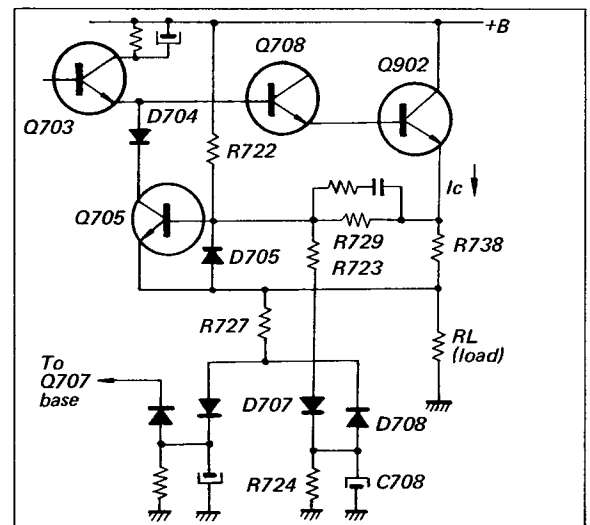

Fig. 1-2. Simplified protection circuit

Stage/Control

Function

When excessive current flows in the power transistor or power dissipation at the collector of power transistor exceeds the specified value, Q705 turns on and limits the input drive voltage to the power transistor. Limiting operation is also actuated by the condition of the load. The base voltage of Q705 is determined by the resistances R738, R729, R723, R724 and RL (load). D707 is employed to stop reverse voltage from applied being during the negative going-half cycle. Q705 turns on limiting the input drive voltage to the power transistor when the load resistance decreases to some extent. Under reactive load conditions in class B amplifiers maximum current will flow when the voltage across the power transistor is maximum and this is the worst case for secondary breakdown. See Fig. 1-3. As all speakers have reactive properties, a protection circuit which covers the reactive region is required.

Fig. 1-3 shows the operating load lines for one half of a class B output stage under con-

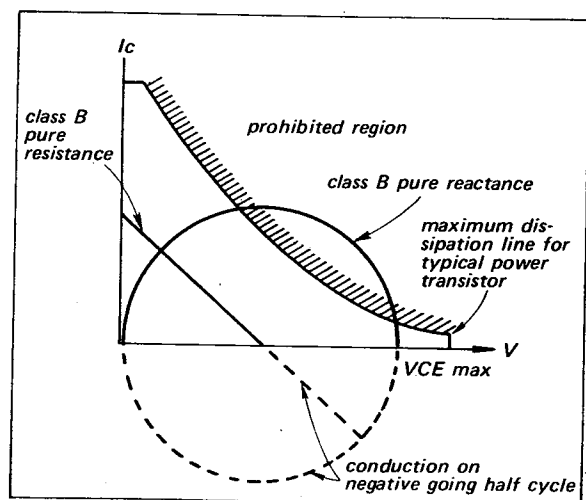

Fig. 1-3. Resistive and reactive load lines for class B output stage showing breakdown risk in purely resistive load

Stage/Control

Function

ditions of equal load impedance; in one case the load is purely resistive and in the other case purely reactive. It is apparent that the reactive load case could result in transistor failure. D708, C708 and R727 form a charging circuit charging the base voltage according to the reactive voltage induced in the load to obtain proper protection operation. C708 and R724 form a discharging circuit to detect reactive dc voltage. D705 protects Q705 from breakdown between base and emitter due to detected reactive voltage across C708. D704 protects Q705 from the breakdown between collector and emitter during the negative-going half cycle.

Q706

Q706 is inserted in the collector circuit of Q707 to increase protection sensitivity of negative going half-cycle.

Power supply
rectifier
D801

A full-wave bridge rectifier provides a positive and a negative dc power supply for the power amplifier.

Rectifier
D802, D803

A half-wave rectifier D802 (D803) and ripple filter (C808, R801) supply well-filtered dc power to the complementary stage.

Ripple filter
Q801
R804, R806
C810
Q802
R803, R805
C809

These components reduce the ripple voltage in the dc power supply for the pre-driver and driver stages of the power amplifier section to an extremely-low value. Q801 and Q802 serve as an electronic filter to supply well filtered dc of about $\pm 54V$ to each stage.

Muting circuit
for tone-
amplifier and
ripple filter
Q803, Q804, Q805
R813, C814

This muting circuit prevents a loud "pop" (due to initial current flow to the tone amplifier) that might damage a delicate high-fidelity speaker system. R813 and C814 comprise an RC network with a long time

Stage/Control

Function

constant. This eliminates popping because Q805 (ripple filter) is brought into conduction gradually.

The base of Q805 is connected to the collector circuit of Q804 through R817, while the base of Q804 is directly coupled to the collector of Q803. At the instant of turning on the power switch S8, Q803 is off due to the long time constant of bias circuit, while Q804 is forward biased by R814 shorting the Q805's base to the ground. Thus, Q805 does not deliver power to the tone amplifier. As Q803 is gradually turned on due to its long time constant circuit Q804 is gradually cut off,

Stage/Control

Function

turning on the Q805. As the result, Q805 is brought into conduction gradually.

Ripple filter
Q805
R816, R817
C815, C816

Reduces the ripple voltages in the dc power supply for the tone amplifier stages to an extremely low value.

Power supply
for tuner section
D804
Q806
D805, D806

Dc output from the rectifier D804 is filtered by C819 and applied to series regulator Q806. Since the voltage at the base of Q806 is kept constant by means of zener diodes D805 and D806, the emitter voltage remains constant regardless of load or line-voltage variations. The regulated and well filtered output of 15V is supplied to the tuner section.

1-3. LEVEL DIAGRAM

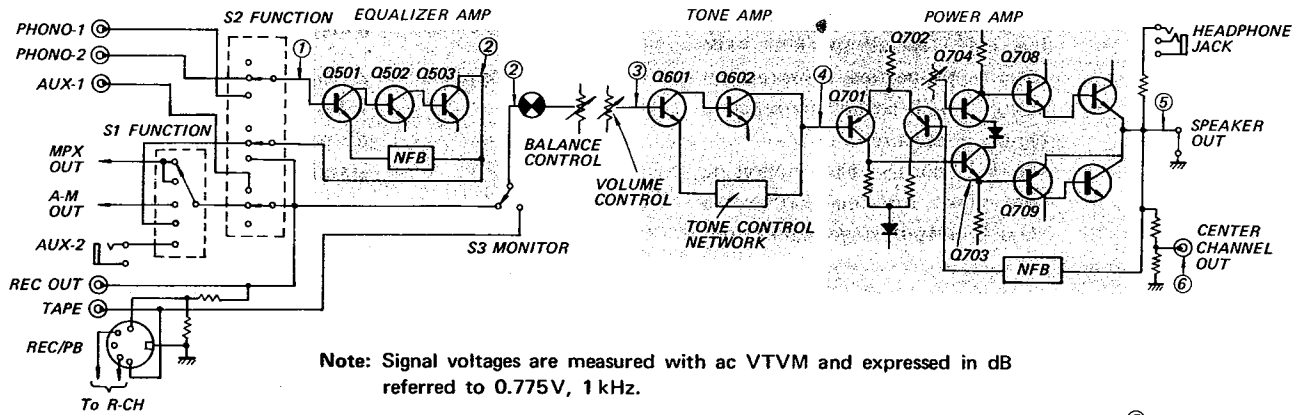

Note: Signal voltages are measured with ac VTVM and expressed in dB referred to 0.775V, 1 kHz.

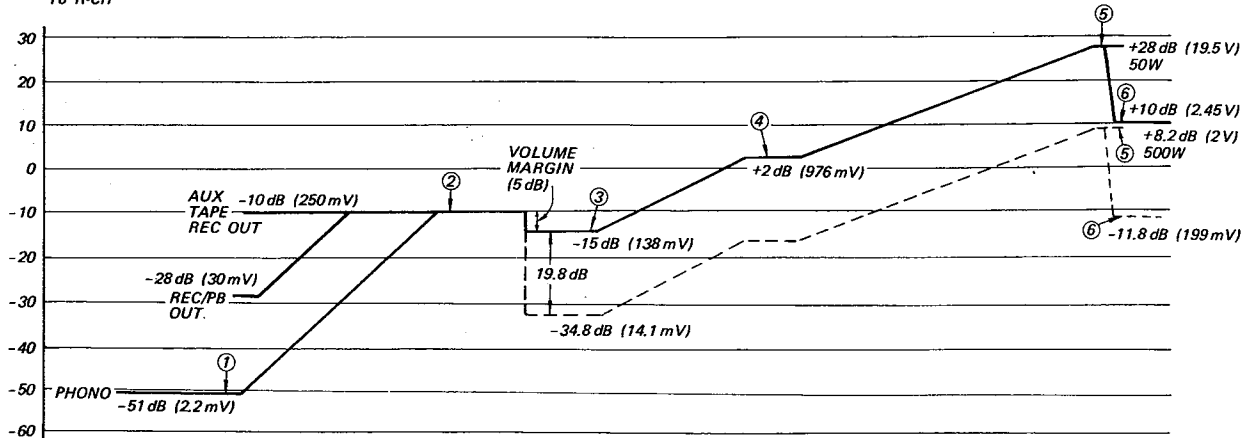

Stage/Control

Function

Stage/Control

Function

Speaker protection circuit

In a direct-coupled power amplifier, some faults in the prior transistor appears as a large unbalanced dc voltage across output terminal. This might damage a delicate speaker system. Therefore, the STR-6065 incorporates speaker protection circuit which operates as follows (refer to Fig. 1-4):

The output signal is extracted from the output terminal through a low-pass filter (R822 or R823, C823 and C824) and fed to the bridge rectifier (D807 ~ D810). Because of

this filter, the voltage applied to the bridge rectifier is only the very-low frequency or dc component caused by transistor faults. When the rectified dc voltage becomes large enough, it starts the Hartley oscillator (Q807 and T801).

The oscillator's output is rectified by D811 and thus provides trigger voltage for SCR D813. When the trigger voltage is applied to the gate of SCR, the SCR turns on and shorts the base voltage of Q708 to ground through R720, D814, the SCR,

1-4. BLOCK DIAGRAM – Tuner Section –

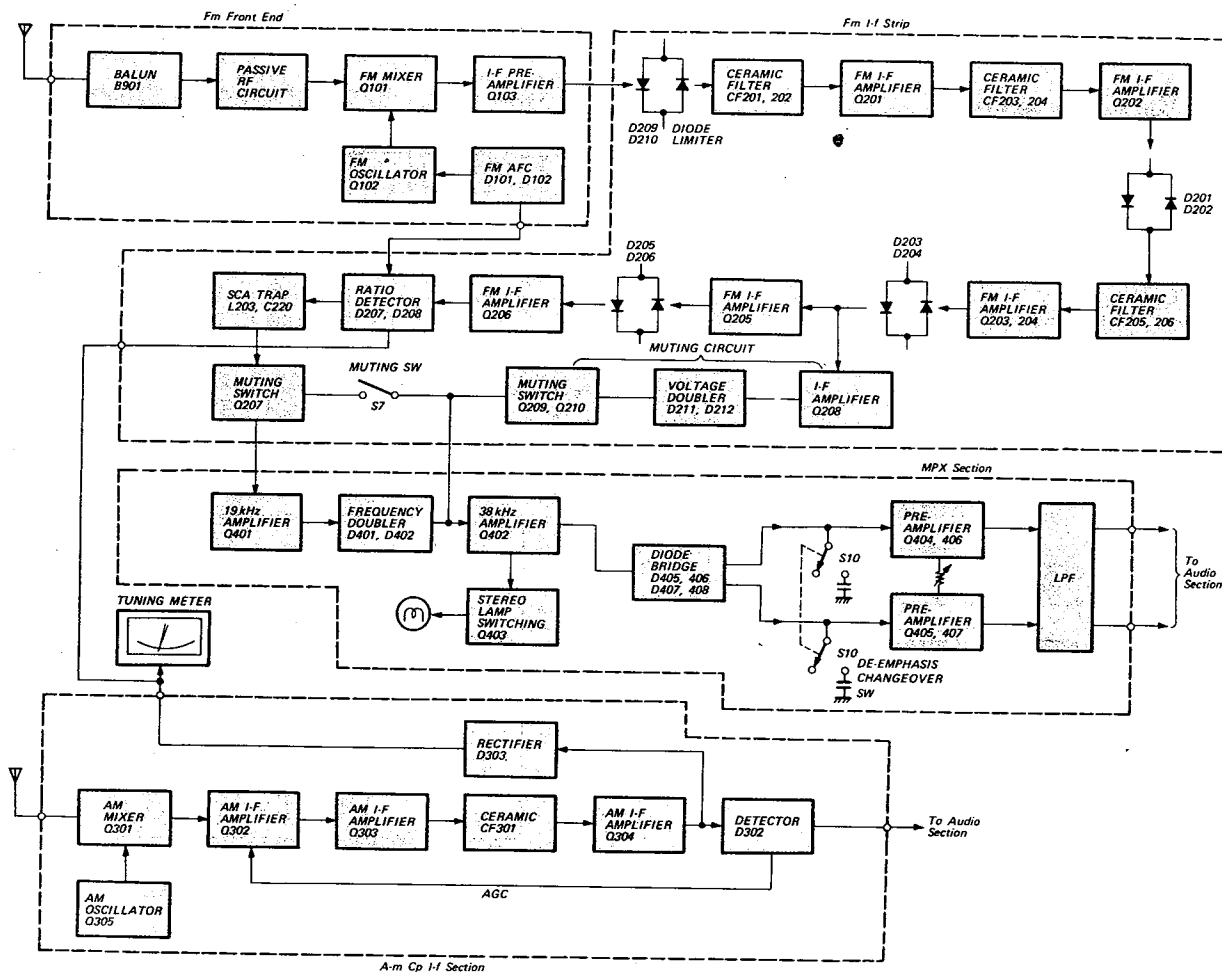

Stage/Control

Function

and D815. The base voltage of Q709 is also shorted to ground through R719, D812, the SCR, and D816, stopping any current flow in the output stage and thus protecting the speaker system. Note that the direction of diodes D812, SCR D813 and D814 which also ensure the speaker protection operation even if one of the power transistors is damaged by accident, forcing the other power transistor into secondary break down.

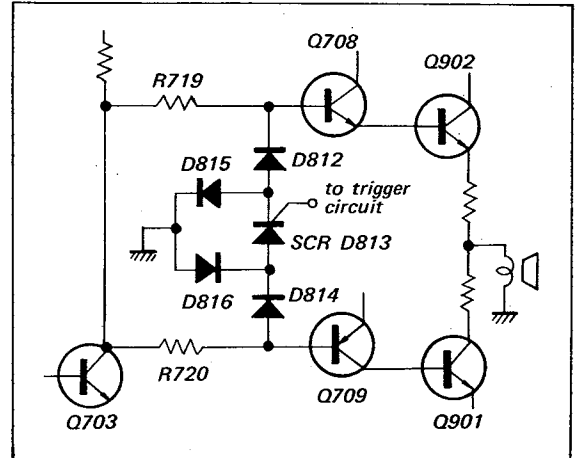
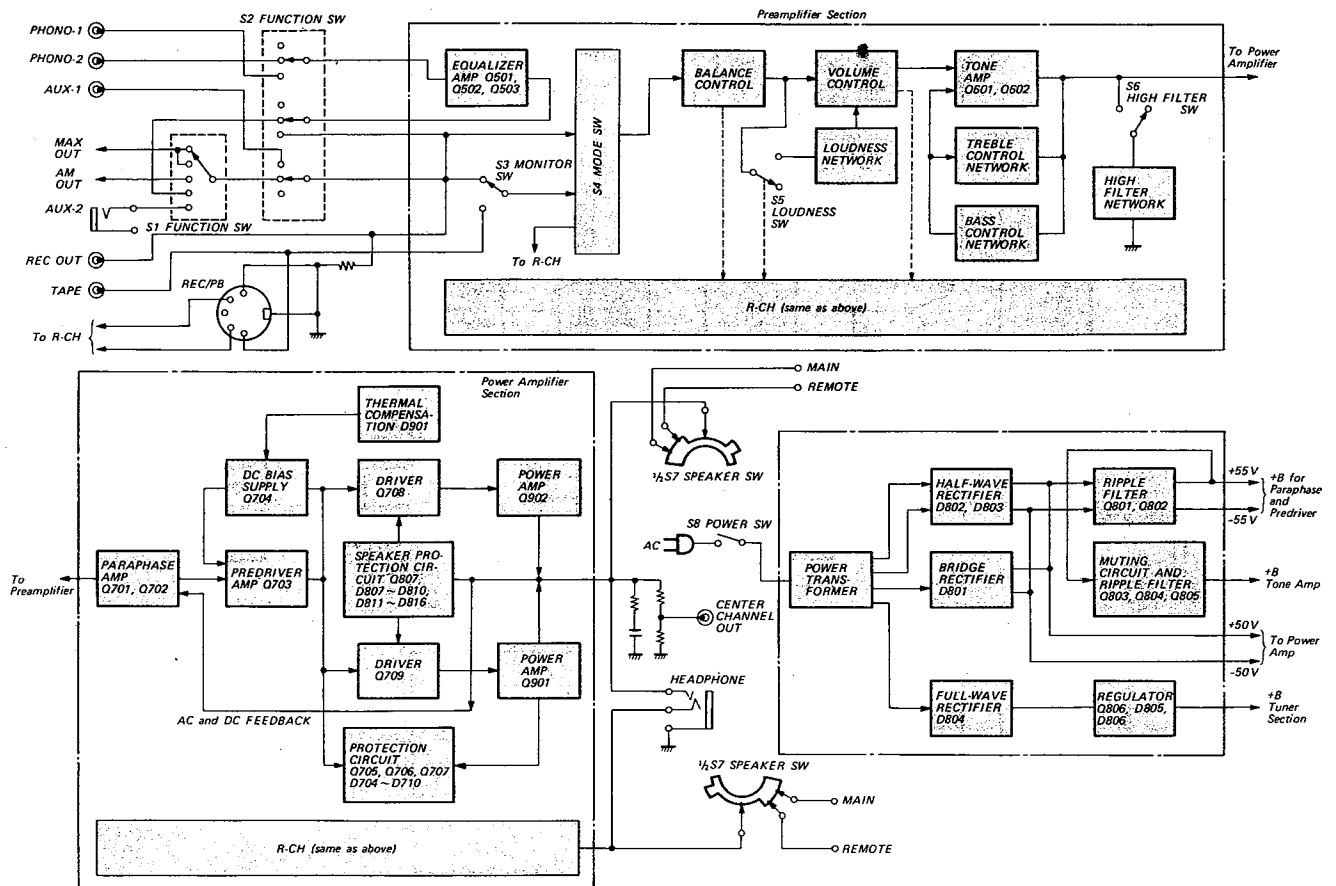

Fig. 1-4 Speaker protection circuit

1-5. BLOCK DIAGRAM – Audio Section –



SECTION 2

DISASSEMBLY AND REPLACEMENT PROCEDURES

WARNING

Unplug the ac power cord before starting any disassembly or replacement procedures.

2-1. TOOLS REQUIRED

The following tools are required to perform disassembly and replacement procedures on the STR-6065.

1. Screwdriver, Phillips-head
2. Screwdriver, 1/8" blade (3 mm)
3. Pliers, long-nose
4. Diagonal cutters
5. Wrench, adjustable
6. Tweezers
7. Electric drill
8. Drill bits
9. Prick punch
10. Hammer, ball-peen
11. Soldering iron, 40 ~ 150 watts
12. Solder, rosin core
13. Cement solvent
14. Cement, contact
15. Thermal compound or silicone grease

2-2. HARDWARE IDENTIFICATION GUIDE

The following chart will help you to decipher the hardware codes given in this service manual.

Note: All screws in the STR-6065 are manufactured to the specifications of the International Organization for Standardization (ISO). This means that the new and old screws are not interchangeable because ISO screws have a different number of threads per mm compared to the old ones. The ISO screws have an identification mark on their heads as shown in Fig. 2-1.

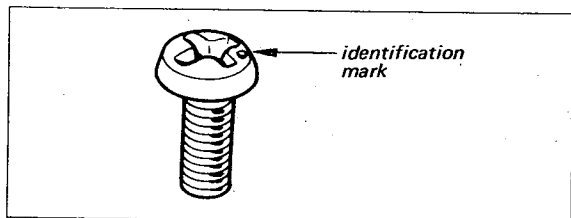

Fig. 2-1. ISO screw

Hardware Nomenclature

P	- Pan Head Screw	⊕	
PS	- Pan Head Screw with Spring Washer	⊕	
K	- Flat Countersunk Head Screw	⊕	
B	- Binding Head Screw	⊕	
RK	- Oval Countersunk Head Screw	⊕	
T	- Truss Head Screw	⊕	
R	- Round Head Screw	⊕	
F	- Flat Fillister Head Screw	⊕	
SC	- Set Screw	⊕	
E	- Retaining Ring (E Washer)	⊕	
	W	- Washer	
	SW	- Spring Washer	
	LW	- Lock Washer	
	N	- Nut	

- Example -

⊕ P 3x10

Length in mm (L)

Diameter in mm (D)

Type of Head

The diagram shows a screw with a diameter of 3 mm and a length of 10 mm. It also shows two different head types, labeled with diameter 'D'.

2-3. TOP COVER AND BOTTOM PLATE REMOVAL

1. Remove the two machine screws at each side of the receiver, and lift off the top cover.
2. Remove the ten self-tapping screws (⊕B 3x6) at the bottom of the receiver as shown in Fig. 2-2. This frees the bottom plate.

2-4. FRONT PANEL REMOVAL

1. Remove the top cover as described in Procedure 2-3.
2. Pull all the knobs off.

3. Remove the two self-tapping screws ($\text{\textcircled{B}}\text{ 3}\times\text{6}$) and two hex-nuts securing the front panel to the front sub-chassis as shown in Fig. 2-3. Place a piece of cardboard or cloth between the wrench and front panel to avoid marring the panel as shown in Fig. 2-4. Now the front panel is free for servicing.

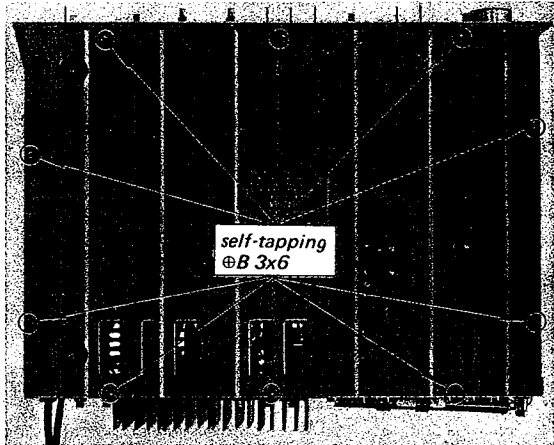

Fig. 2-2. Bottom plate removal

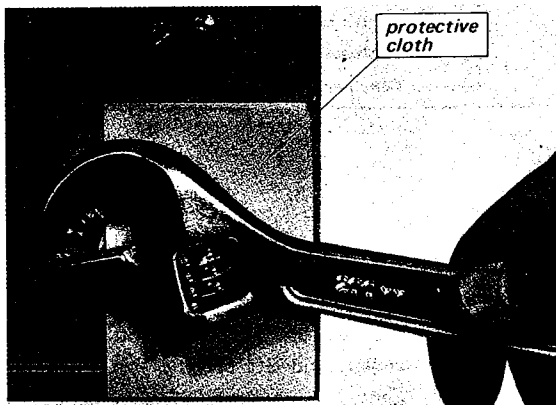

Fig. 2-4. Hex nut removal

2-5. DIAL-CORD RESTRINGING

Preparation

1. Remove the top cover as described in Procedure 2-3.
2. Cut a 1,500 mm (59") length of dial cord.
3. Tie the end of the cord to a spring as shown in Fig. 2-5.
4. Rotate the tuning-capacitor drive drum fully clockwise (minimum capacitance position).

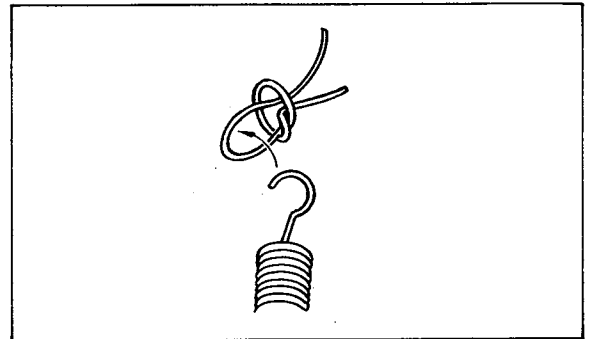

Fig. 2-5. Tying square knot to the coil spring

Procedure

While referring to Fig. 2-6, proceed as follows:

1. Hook the spring to one hole of the drive drum as shown in Fig. 2-7.
2. Run the cord through the slot in the rim of the drum and wrap a half clockwise turn in the inner groove.
3. Run the cord over pulley "A" and, then wrap two counterclockwise turns around the tuning shaft.

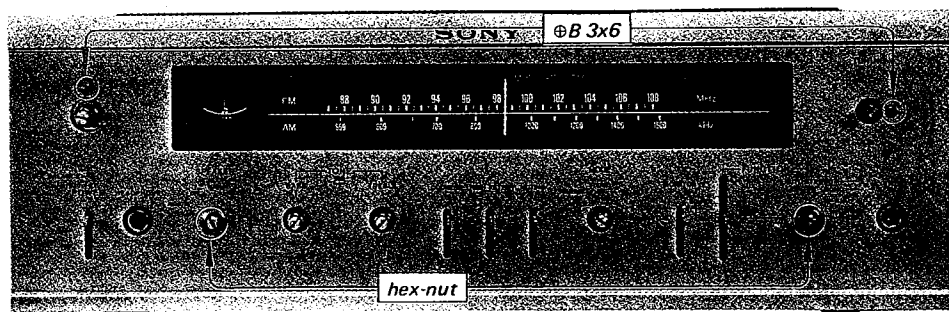

Fig. 2-3. Front panel removal

4. Run the cord over pulleys "B", "C" and "D", then wrap two clockwise turns around the drum from outer groove to inner groove as shown in Fig. 2-8.
5. Pass the doubled end of the cord through the eyelet, then hook it to the spring as shown in Fig. 2-9.

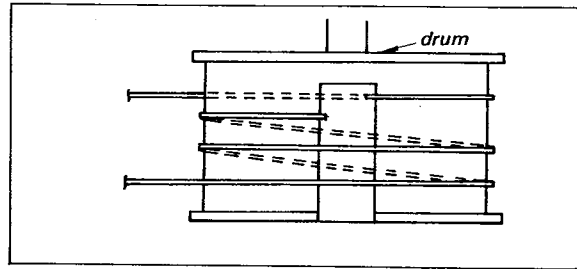

Fig. 2-8. Wrapping the dial cord

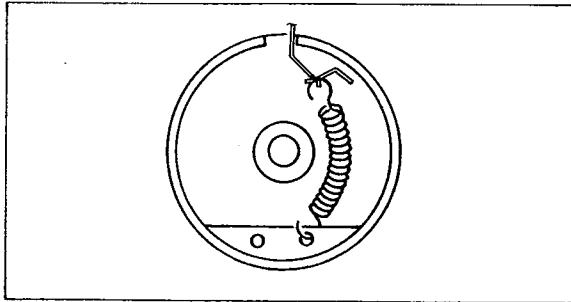

Fig. 2-7. Coil spring installation

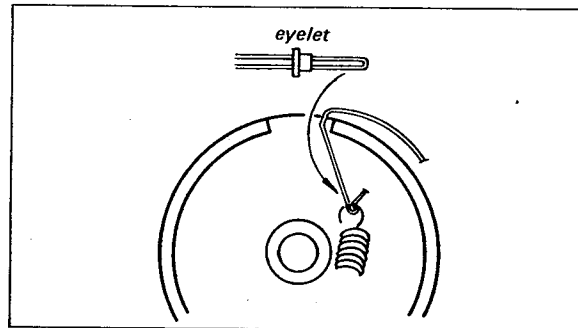

Fig. 2-9. Finishing dial cord stringing

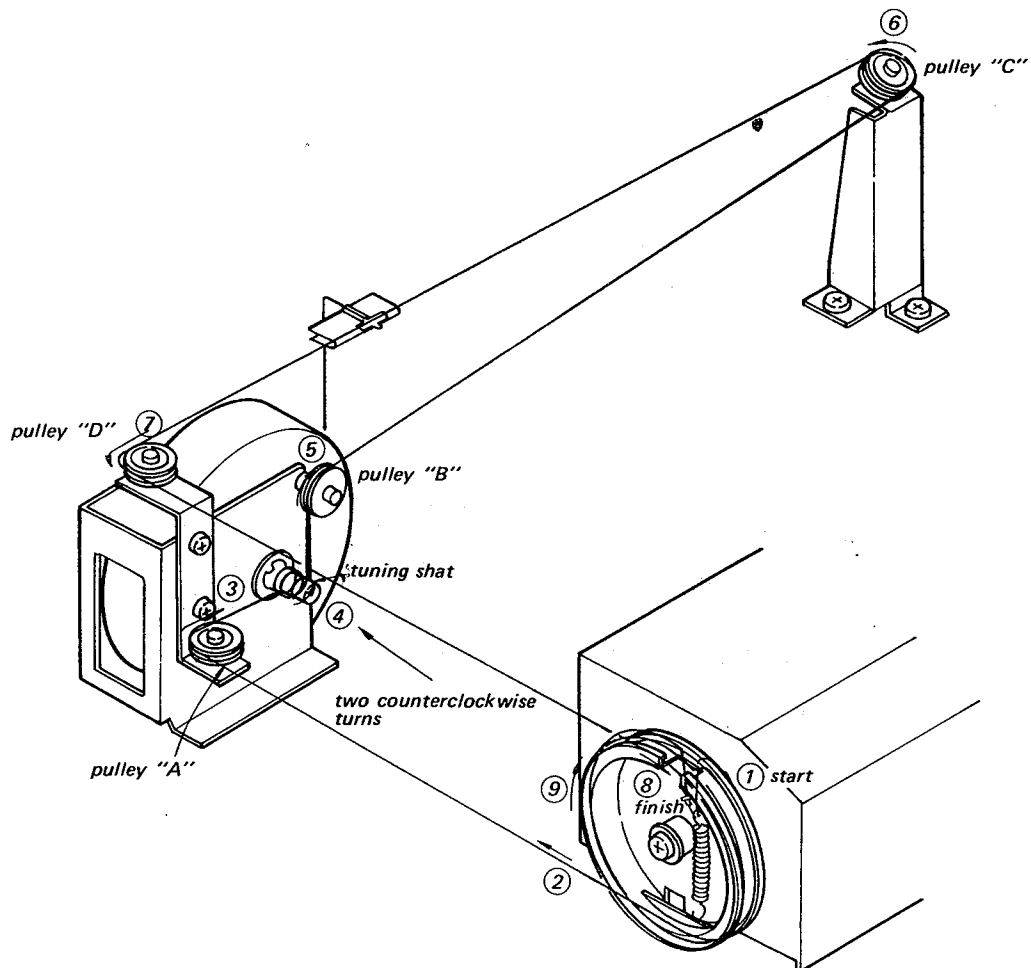

Fig. 2-6. Dial cord stringing

6. Tighten the cord, then squeeze the eyelet so that the spring is under tension. Make a knot in the cord end to keep it from slipping out of the eyelet.
7. After completing the dial-cord stringing, make sure that the tuning system works properly. Apply a drop of contact cement to the finish point.

2-6. MECHANICAL DIAL CALIBRATION

Note: This is required after replacing the dial cord, dial scale or front-end assembly.

1. Put the dial pointer on the cord as shown in Fig. 2-10 and move it to a position where the pointer coincides with the left gap on the dial scale as shown in Fig. 2-11, when the tuning capacitor is set to the maximum capacitance.
2. Apply a drop of contact cement to the tab of the dial pointer.

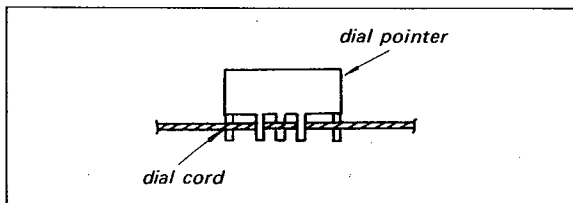

Fig. 2-10. Dial pointer installation

2-7. DIAL SCALE REPLACEMENT

1. Remove the top cover as described in Procedure 2-3.

2. Remove the front panel as described in Procedure 2-4.
3. Remove the two self-tapping screws ($\text{Ø} B 3 \times 6$) securing the dial-scale holder to the front sub-chassis as shown in Fig. 2-12.
4. Remove the defective dial scale and then install the replacement scale.

2-8. PILOT-LAMP REPLACEMENT

Prepare for replacement any of the pilot lamps by removing the top cover as described in Procedure 2-3.

Meter Lamp

1. Straighten the tab of the meter-lamp holder to permit the removal of the meter-lamp socket.
2. Pull out the meter-lamp socket, and then unscrew the lamp from the socket and install the new lamp.

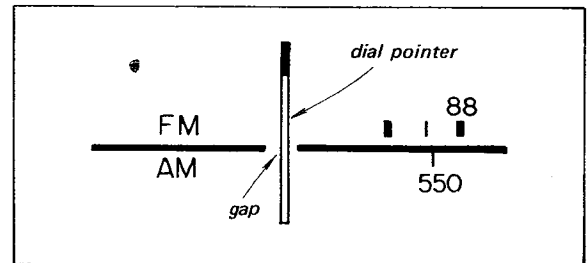

Fig. 2-11. Mechanical dial calibration

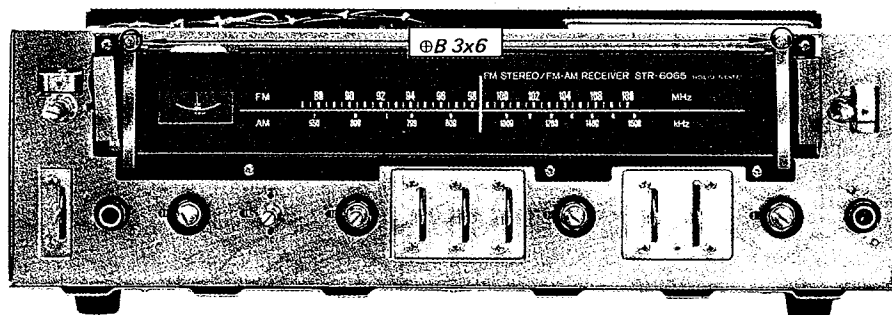

Fig. 2-12. Dial scale removal

Stereo Lamp

1. Pull the lamp and rubber grommet from its holder with tweezers as shown in Fig. 2-13.
2. Cut the lamp leads and solder the lead wires to the new lamp as shown in Fig. 2-14.
3. Wrap the soldered connections with electrical tape.
4. Install the new lamp in its holder.

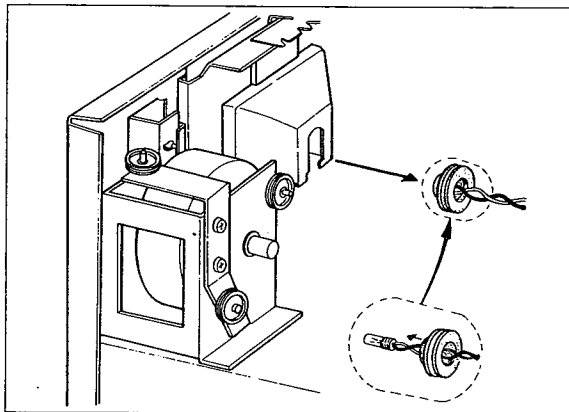

Fig. 2-13. Stereo lamp removal

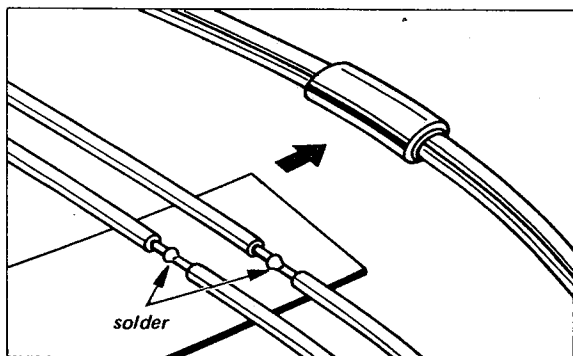

Fig. 2-14. Stereo lamp replacement

Dial Lamp

1. Remove the front panel as described in Procedure 2-4.
2. Pry out the fiber lamp shade, and then remove the lamp.

2-9. TUNING METER REPLACEMENT

1. Remove the top cover as described in Procedure 2-3.
2. Unsolder the leads from the defective meter.

3. Remove the two self-tapping screws ($\text{B } 3 \times 6$) securing the meter holder to the chassis as shown in Fig. 2-15.
4. Remove the meter, and install the new one.

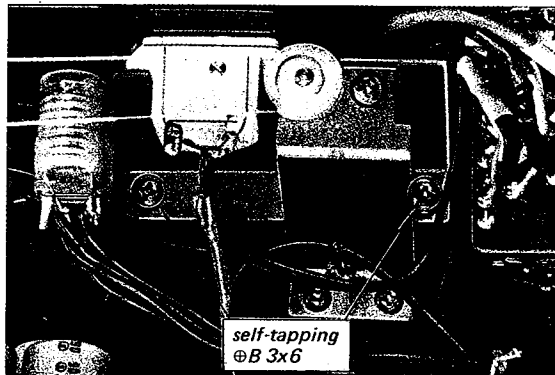

Fig. 2-15. Meter holder replacement

2-10. CONTROL AND SWITCH REPLACEMENT

Prepare for replacing any of the controls or switches by removing the wooden case as described in Procedures 2-3 and 2-4. Refer to Fig. 2-16.

TONE Controls

1. Apply a drop of cement solvent to the ring spacer on the TREBLE control. Wait a few seconds for the cement to dissolve, and pry out the spacer with a screw driver.
2. Remove the hex nuts that secure the BASS and TREBLE controls to the front-subchassis.
3. Carefully remove them along with the tone-control circuit board.
4. Cut each lug of the defective control on the board to remove the part.
5. Unsolder and remove the cipped lugs, and clean out the holes of the circuit board.
6. Install the replacement control.

POWER, HIGH FILTER, MUTING, MONITOR, FUNCTION (2), LOUDNESS Switches

1. Remove the two screws ($\text{PS } 3 \times 6$) securing switches to the front subchassis as shown in Fig. 2-16.
2. Unsolder the lead wires from the defective switch, and then install the replacement switch.

SPEAKER, MODE, FUNCTION (1) Switches

1. Apply a drop of cement solvent to the ring spacer on the switches. Wait a few seconds for the cement to dissolve, and pry out the spacer with a screw driver.
2. Remove the hex nuts that secure the switches to the front-subchassis as shown in Fig. 2-16.
3. Unsolder the lead wires from the defective switch, and then install the replacement switch.

2-11. REAR PANEL REMOVAL

1. Remove the top cover and bottom plate as described in Procedure 2-3.
2. Unsolder the lead wire connecting between ground terminal and chassis.
3. Unsolder the coaxial cable from fm antenna terminal.
4. Remove the six self-tapping screws (⊕B 3x6),

two of them secure the bar antenna holder to the chassis along with rear panel and others secure the rear panel to the chassis as shown in Fig. 2-17. This frees the rear panel.

2-12. REPLACEMENT OF COMPONENTS SECURED TO THE REAR PANEL BY RIVETS

1. Remove the rear panel as described in Procedure 2-11.
2. Bore out the rivets using a drill bit slightly larger in diameter than the rivet. See Fig. 2-18.
3. Punch out the remainder of the rivet with a nail set or prick punch.
4. Remove the defective component, and install the new one.
5. Secure the new component with a suitable screw and nut, or a repair rivet screw (Part No. 3-701-402).

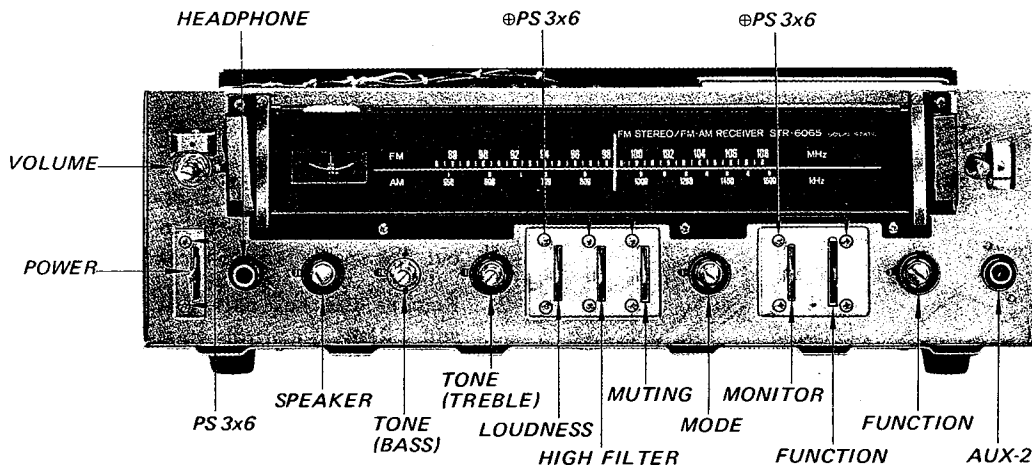

Fig. 2-16. Control and switch replacement

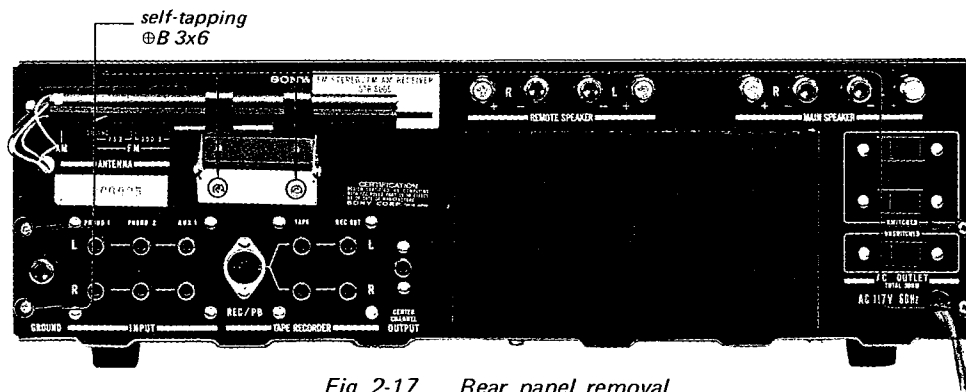

Fig. 2-17. Rear panel removal

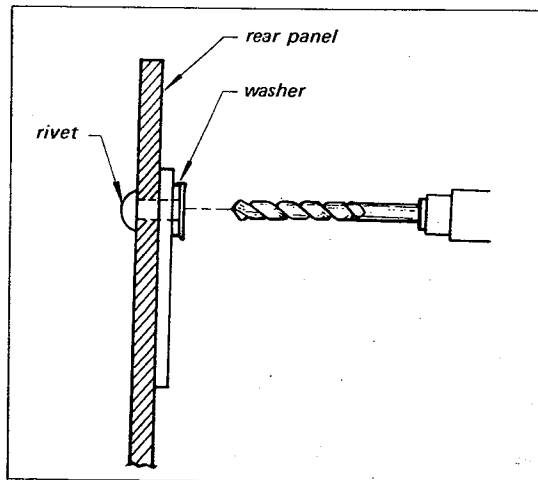

Fig. 2-18. Rivet replacement

2-13. POWER TRANSISTOR REPLACEMENT

1. Remove the top cover and bottom plate as described in Procedure 2-3.
2. Remove the eight self-tapping screws ($\oplus B 3 \times 8$), ($\oplus P 3 \times 8$) securing the heat sink to the chassis as shown in Fig. 2-19, and then remove the four self-tapping screws ($\oplus B 3 \times 8$) securing the heat sink support to the top of the heat sinks.
3. Cut the emitter and base leads of the defective power transistor with a diagonal cutter. This prevents damage to the mica washer when remove the defective power transistor.
4. Carefully draw back the heat sink, and then remove the two screws ($\oplus B 3 \times 14$) and nuts securing the power transistor to the heat sink.
5. When replacing the power transistor, apply a coating of a thermal compound or a heat-transferring grease to both sides of the insulating mica washer. Any excess compound or grease squeezed out when the mounting bolts are tightened should be wiped off with a clean cloth. This prevents accumulation of conductive dust particles that might eventually cause a short.

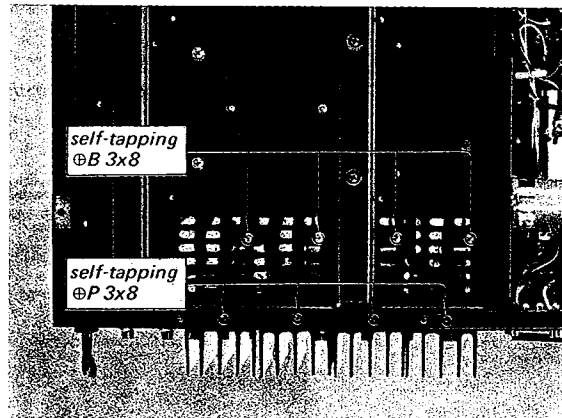
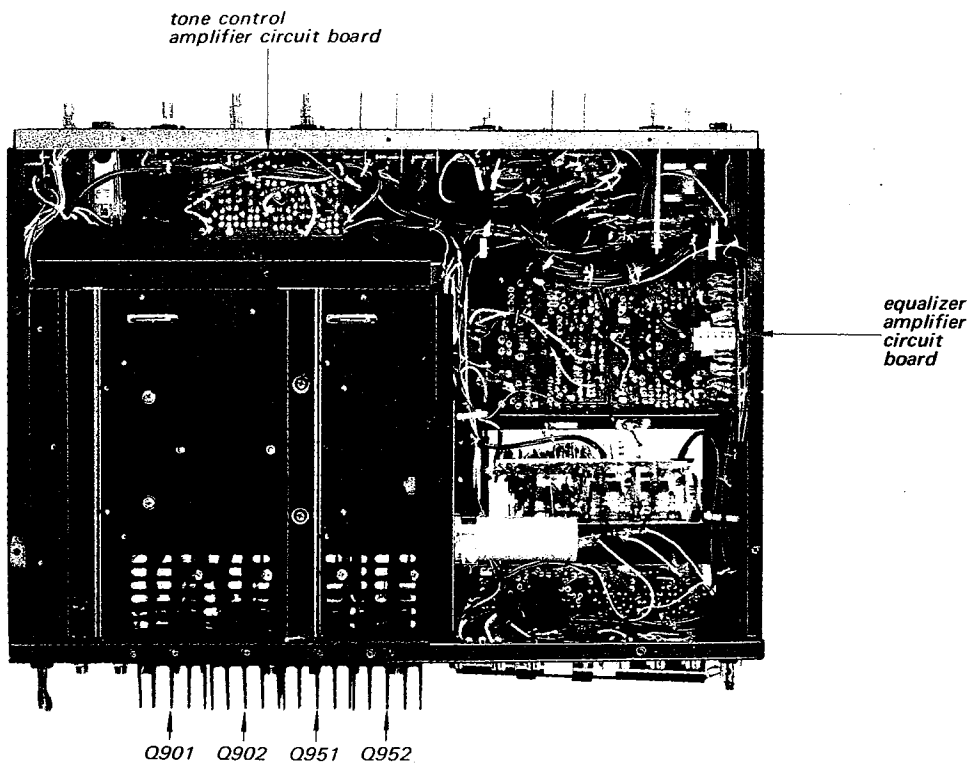
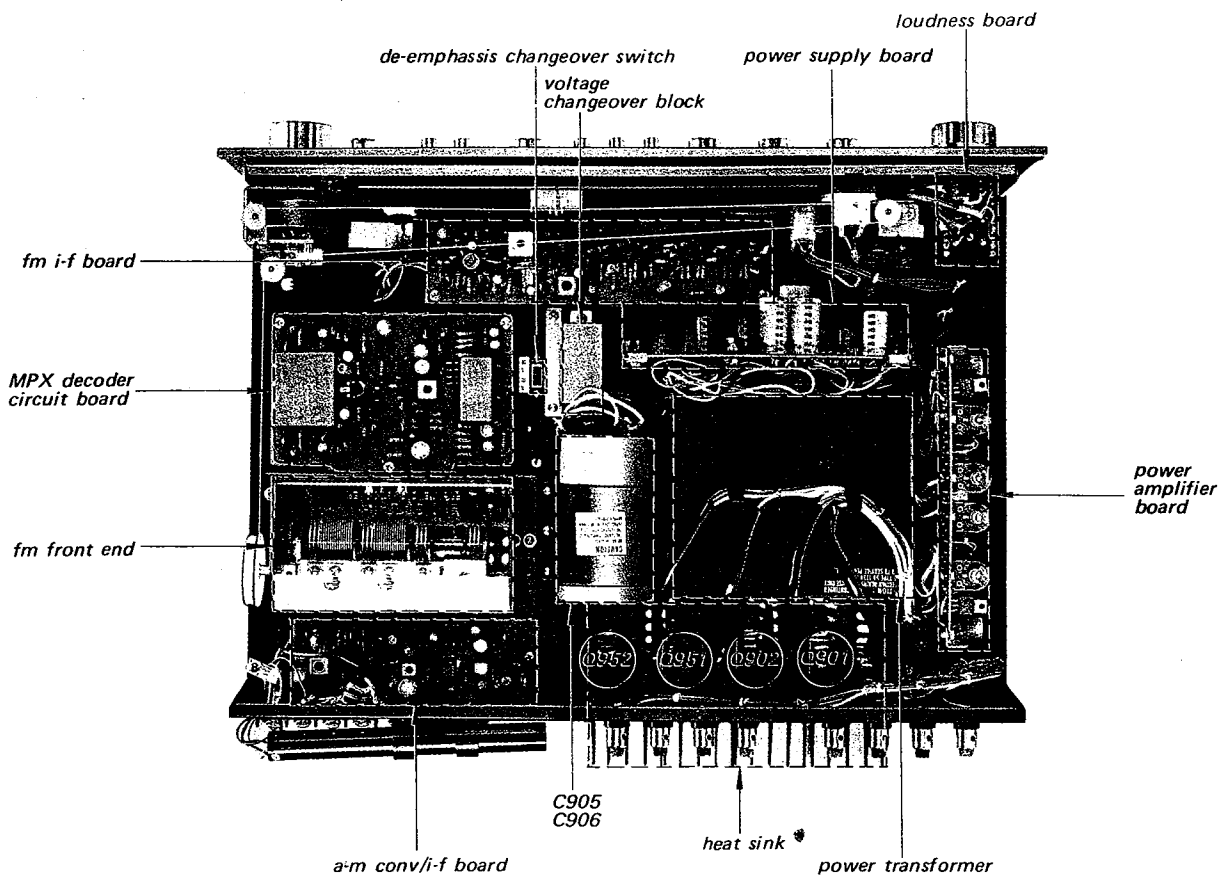

Fig. 2-19. Heat sink removal

2-14. CHASSIS LAYOUT



SECTION 3 ALIGNMENT AND ADJUSTMENT PROCEDURES

3-1. FM I-F STRIP ALIGNMENT

CAUTION

The ceramic filters in the fm i-f circuit are selected according to their specified center frequencies and color coded as shown in Fig. 3-1 and listed in Table 3-1. Check the color code of the filters to identify the same center frequency when replacing any of these filters.

TABLE 3-1.

FM I-F CERAMIC FILTERS

Part No.	Color	Specified Center Freq.
1-403-562-11	red	10.70 MHz
1-403-562-21	black	10.66 MHz
1-403-562-31	white	10.74 MHz
1-403-562-41	green	10.62 MHz
1-403-562-51	yellow	10.78 MHz

Test Equipment Required

1. Standard fm signal generator
2. Ac VTVM
3. Oscilloscope
4. Alignment tools

Note: This alignment is needed only after IFT101 in the front end or T201 (discriminator transformer) has been replaced.

Preparation

1. Remove the top cover as described in Procedure 2-3.
2. Remove the front-end cover by loosening the two screws securing it to the chassis.
3. Connect the input cable of the ac VTVM to the REC OUT terminal (J105).

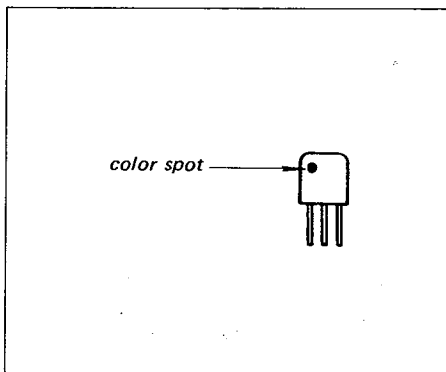

Fig. 3-1. Fm i-f ceramic filter

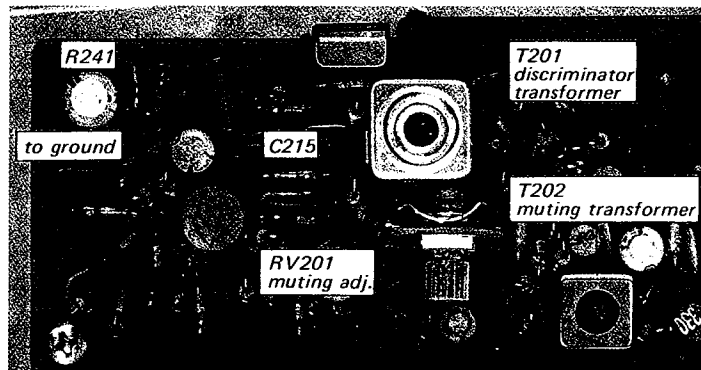

Fig. 3-2. Interruption of afc circuit and parts location

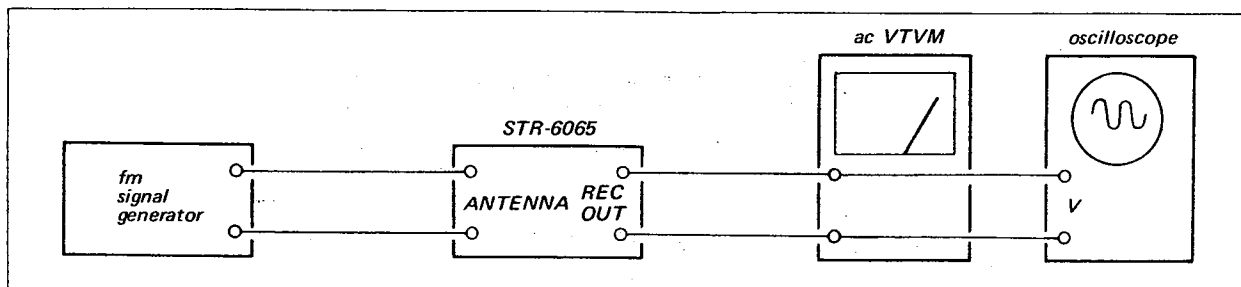

Fig. 3-3. Fm i-f, muting and front end alignment test setup

4. Connect the signal-generator's output to the fm antenna terminal.
5. Short the connection point of R242 and C215 (AFC circuit) to ground as shown in Fig. 3-2.

Procedure

1. With the equipment connected as shown in Fig. 3-3, set the signal-generator's controls as follows:
 Carrier frequency 98 MHz
 Modulation Fm, 400 Hz, 100%
 Output level 30 μ V (30 dB)
2. Set the receiver's controls as follows:
 FUNCTION switch FM MONO
 MODE switch STEREO
 VOLUME control Minimum
3. Turn the core of transformer IFT101 or T201 (bottom core) (See Fig. 3-2 or Fig. 3-4) with the alignment tool to obtain maximum output.

3-2. FM DISCRIMINATOR ALIGNMENT

Note: Before starting this alignment, the fm i-f alignment should be performed. There are two or three methods of discriminator alignment, but only the simplified method using the tuner's TUNING meter is described here.

Test Equipment Required

1. Oscilloscope
2. Alignment tools

Preparation

1. Remove the top cover as described in Procedure 2-3.
2. Connect the input cable of the oscilloscope to REC OUT (J105) terminal.
3. Short the connection point of R242 and C215 (AFC circuit) to ground as shown in Fig. 3-2.

Procedure

1. With the equipment connected as shown in Fig. 3-5, set the receiver's control as follows:
 FUNCTION switch FM MONO
 MODE switch STEREO
 No signal should be received.
2. Adjust the controls of the oscilloscope to provide a visible indication of noise. Always watch the oscilloscope to confirm that the tuner is not receiving any off-the-air signals.
3. Turn the top core (secondary side) of discriminator transformer T201 (see Fig. 3-2) with a hex-head alignment tool to obtain a null-point reading on the tuning meter. If the discriminator transformer (T201) is not aligned correctly, some deviation on the tuning meter will be observed.

Note: Turn the core carefully and slowly. At both extreme positions of the top core, a null point will be observed. The real null point should be obtained in the middle of the core's thread length.

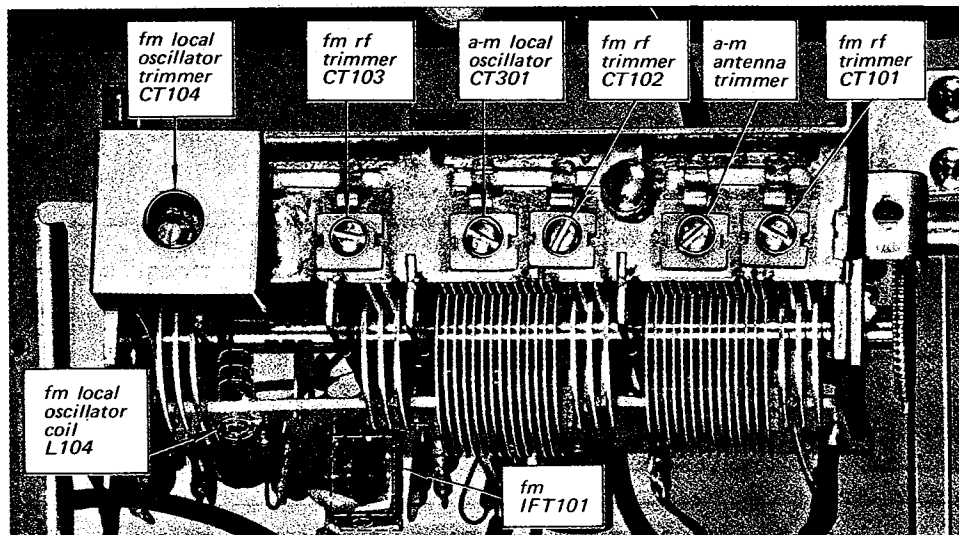

Fig. 3-4. Parts location

- Repeat the above mentioned steps and fm i-f strip alignment two or three times.

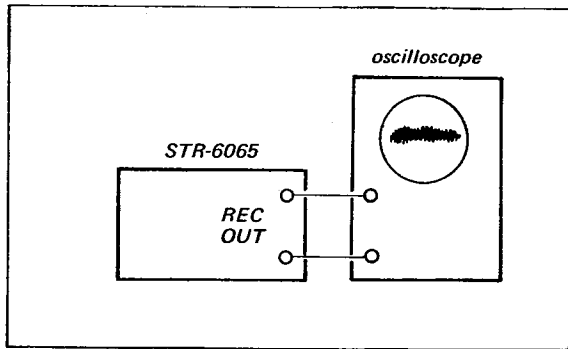

Fig. 3-5. Discriminator alignment test setup

FUNCTION switch FM MONO
 MODE switch STEREO
 MUTING switch ON

- Follow the procedure given in Table 3-2. Note that the muting circuit should begin to operate at the symmetrical deflection point of TUNING meter when detuning the tuner to higher or lower than the reference carrier frequency.

Off-the-Air Signal Alignment

Accurate muting circuit adjustment can also be performed by utilizing off-the-air local fm signals instead of the fm S.S.G.

Note that a weak signal is best for this purpose.

3-3. MUTING ADJUSTMENT

Note: Two methods of muting alignment are available, signal generator alignment and alignment by using an off-the-air signal. You can use either of them.

Signal Generator Alignment

Test Equipment Required

- Fm standard signal generator
- Ac VTVM or oscilloscope
- Alignment tool

Preparation

- Remove the top cover as described in Procedure 2-3.
- Turn the knob of RV201 (see Fig. 3-2) fully clockwise on the fm i-f and discriminator board.
- Short the connection point of R242 and C215 (AFC circuit) to ground as shown in Fig. 3-2.

Procedure

- With the equipment connected as shown in Fig. 3-3, set the receiver's controls as follows:

3-4. FM FREQUENCY COVERAGE ALIGNMENT

CAUTION

Never attempt alignment of the front-end section except for the frequency-coverage and dial-calibration adjustments. The front-end section of the tuner has been carefully adjusted at the factory, so very little adjustment is necessary in the field. Alignment need not be performed when the front-end FET is replaced since changes in FET parameters have little effect upon tuning. If an rf-stage adjustment is required, ask your nearest SONY Service Station to send your unit to the Factory Service Center for a complete front-end alignment. Exercise caution when returning the faulty unit so that it is not damaged in transit. The warranty will not cover damage incurrent in transit to the Factory Service Center.

Note: Before starting this alignment, the discriminator-transformer alignment should be performed.

TABLE 3-2. MUTING ADJUSTMENT

Coupling Between Front End and SSG	SSG Frequency and Output Level	Tuner Dial Indication	Adjust	Remarks
Direct coupling	98 MHz 400 Hz. 30% Mod.	98 MHz	T202 See Fig. 3-2	Turn the core of T202 to obtain proper muting operation.

TABLE 3-3. FM FREQUENCY COVERAGE ADJUSTMENT

Step	Coupling Between Front End and SSG	SSG Frequency and Output Level	Tuner Dial Indication	Scope Connection	Adjust	Indication
1.	Direct coupling	87.5 MHz 400 Hz 100% Mod. 30 μ V (30 dB)	87.5 MHz	REC OUT (J105)	OSC coil L104 See Fig. 3-4	Maximum VTVM reading
2.	Same as above	108 MHz 400 Hz 100% Mod. 30 μ V (30 dB)	108 MHz	Same as above	OSC trimmer CT104 See Fig. 3-4	Same as above

Signal Generator Alignment

Test Equipment Required

1. Standard fm signal generator
2. Ac VTVM
3. Alignment tools

Preparation

1. Remove the top cover as described in Procedure 2-3.
2. Connect the equipment as shown in Fig. 3-3.
3. Set the receivers controls as follows:
 FUNCTION switch FM MONO
 MODE switch STEREO
4. Short the connection point of R242 and C215 (AFC circuit) to ground as shown in Fig. 3-2.

Generator Alignment

Follow the procedures given in Table 3-3 when performing this alignment with an fm signal generator. Be sure that the dial is mechanically calibrated as described in Procedure 2-6.

Off-the-Air Alignment

Accurate dial calibration and a frequency-coverage test can also be performed by utilizing off-the-air local fm signals. However, before performing the following procedure, be sure that the dial pointer is correctly positioned, as described in Procedure 2-6.

Procedure

1. Short the connection point of R242 and C215 (AFC circuit) to ground as shown in Fig. 3-2.
2. Tune the receiver to the lowest-frequency station.

3. Check the dial scale for a calibration accuracy of ± 200 kHz from the carrier frequency of the station. If the dial-accuracy deviation exceeds this limit, turn the local-oscillator coil L104 slightly as shown in Fig. 3-4 until optimum dial calibration is obtained.
4. Tune the receiver to the highest-frequency station in your locality. If the dial-calibration error is excessive, adjust local-oscillator trimmer CT104 (see Fig. 3-4) to obtain maximum calibration accuracy.
5. Repeat Steps 3 and 4.

3-5. FM STEREO SEPARATION ADJUSTMENT

Test Equipment Required

1. MPX generator
2. Fm signal generator
3. Audio oscillator
4. Ac VTVM
5. Oscilloscope
6. Alignment tools

Preparation

Before starting the stereo-separation adjustment, check and adjust the phase between the 19-kHz pilot signal and the sub-channel signal in the MPX stereo generator as follows:

- (1) With the equipment connected as shown in Fig. 3-6, set the MPX and audio signal-generator's control as follows:
 MAIN CHANNEL OFF
 SUB CHANNEL ON
 PILOT (19 kHz) OFF

AUDIO OSCILLATOR

OUTPUT 400 Hz,
250 mV

- (2) Adjust the oscilloscope controls to obtain a visible indication. Be sure the scope's horizontal display switch is set for external input.
- (3) Turn the pilot-signal (19 kHz) phase control to obtain an in-phase and stable lissajous pattern as shown in Fig. 3-7.

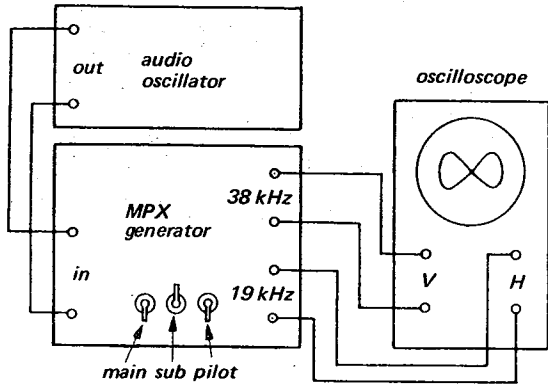

Fig. 3-6. MPX generator preadjustment

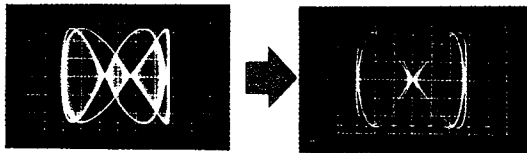

Fig. 3-7. Lissajous pattern

Procedure

1. Connect the equipment as shown in Fig. 3-8. Set the fm signal-generator's control as follows:
Carrier frequency 98 MHz
Output level 1,000 μV (60 dB)
Modulation:
Main channel (400 Hz) ... 33.75 kHz (45%)
Sub channel (38 kHz) ... 33.75 kHz (45%)
Pilot (19 kHz) 7.5 kHz (10%)

The above mentioned modulation levels can be set as follows:

- (a) With the equipment connected as shown in Fig. 3-8 set the MPX stereo generator controls as follows.
MAIN CHANNEL OFF
SUB CHANNEL OFF
19 kHz (PILOT) ON
- (b) Adjust the 19-kHz signal level to obtain a 7.5-kHz deviation on the FM SSG modulation indicator.
- (c) Reset the MPX stereo-generator's control as follows:
MAIN CHANNEL ON
SUB CHANNEL OFF
19 kHz (PILOT) OFF
INPUT SELECTOR L-CH
- (d) Adjust the audio-oscillator output (400 Hz) to obtain a 33.75-kHz deviation on the FM SSG modulation indicator.
- (e) Set all controls to ON.

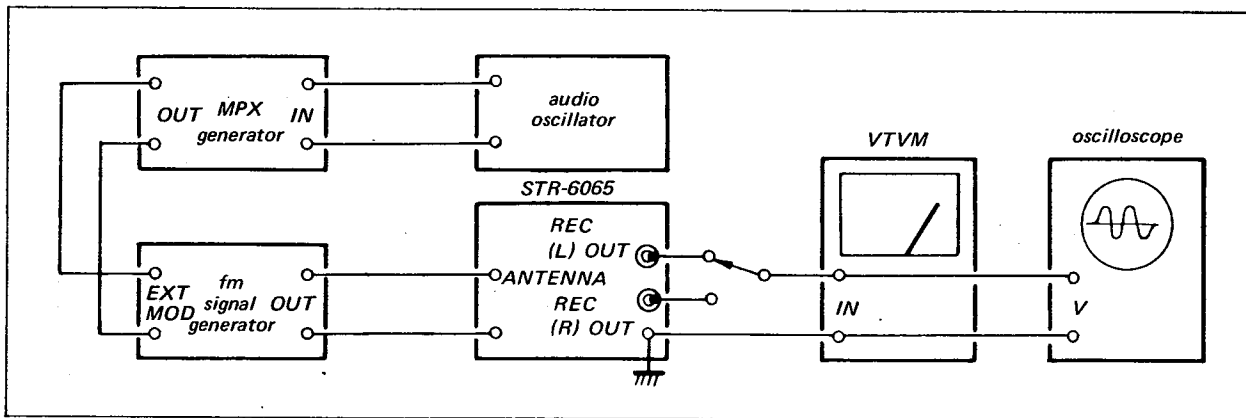

Fig. 3-8. Fm stereo separation adjustment test setup

3-6. A-M I-F STRIP ALIGNMENT

Preparation

Remove the top cover as described in Procedure 2-3. Then set the receiver's FUNCTION selector to AM.

Note: To perform this alignment, the local oscillator should be killed. To do this, shunt the local oscillator capacitor with a 0.02- μ F capacitor as shown in Fig. 3-10.

Sweep Generator Alignment

Test Equipment Required

1. Sweep generator, 455 kHz
2. Oscilloscope
3. Alignment tools

Procedure

1. Connect the sweep generator's output directly to the a-m antenna terminal.
2. Connect the input cable of the oscilloscope to R321 (see Fig. 3-10) and ground on the a-m cp i-f board with alligator clips as shown in Fig. 3-10.
3. Set the sweep generator's control as follows:
 Center frequency 455 kHz
 Sweep width 25 kHz
 Output as low as possible
4. With the equipment connected as shown in Fig. 3-12, adjust the oscilloscope controls and generator output to provide a visible indication.

5. Turn the top core of IFT301 (see Fig. 3-10) to obtain a maximum and symmetrical response as shown in Fig. 3-11.

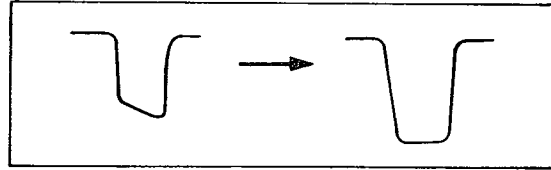

Fig. 3-11. A-m i-f strip alignment by sweep generator

Rf Signal Generator Alignment

Test Equipment Required

1. Signal generator, 455 kHz, a-m modulation
2. Oscilloscope or VTVM
3. Alignment tools

Procedure

1. Set the rf signal generator's controls as follows:
 Modulation INTERNAL
 Frequency 455 kHz
 OUTPUT level 1,000 μ V
2. Connect the rf signal-generator's output to a-m antenna terminal.
3. With the equipment connected as shown in Fig. 3-13, turn the top core of IFT301 (see Fig. 3-10) to obtain maximum output.

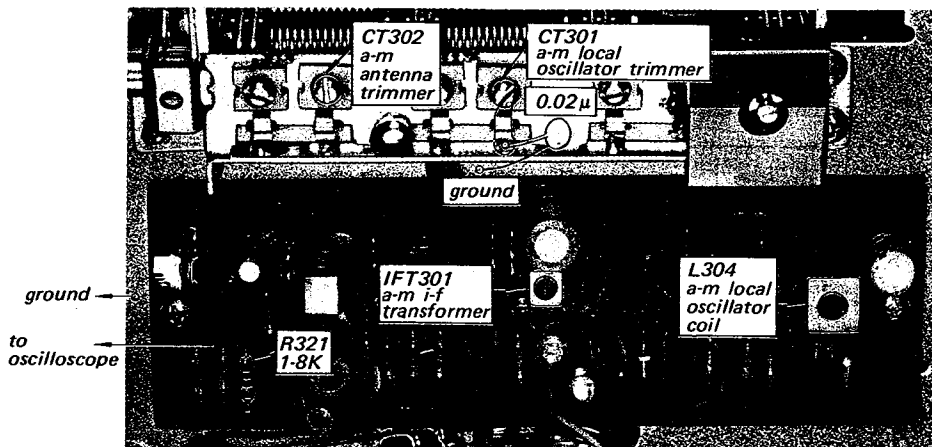

Fig. 3-10. Disabling the a-m local oscillator, a-m detector output connection and parts location

3-7. A-M FREQUENCY COVERAGE AND TRACKING ADJUSTMENT

Signal Generator Method

Test Equipment Required

1. Standard a-m signal generator
2. Loop antenna
3. Ac VTVM or oscilloscope

Preparation

Remove the top cover as described in Procedure 2-3. Then, set the FUNCTION switch to AM.

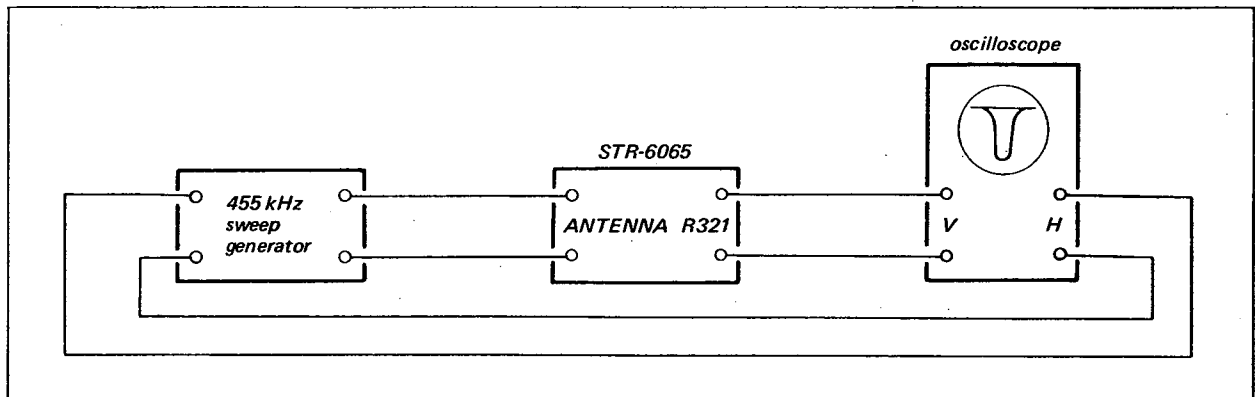

Fig. 3-12. A-m i-f strip alignment by sweep generator

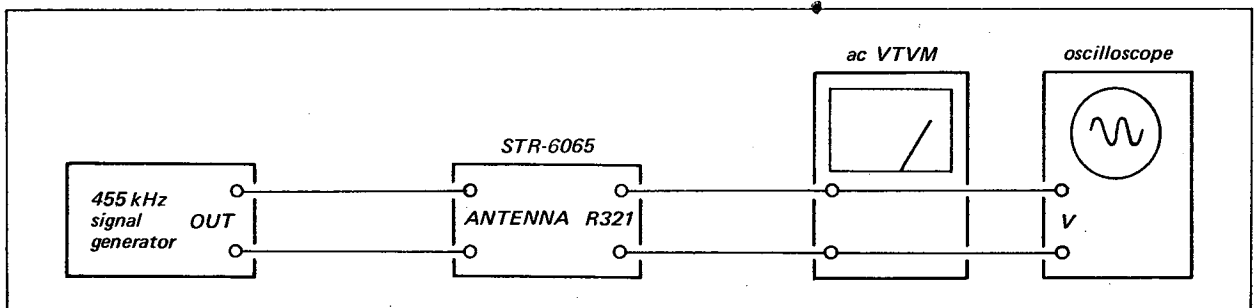

Fig. 3-13. A-m i-f strip alignment by rf generator

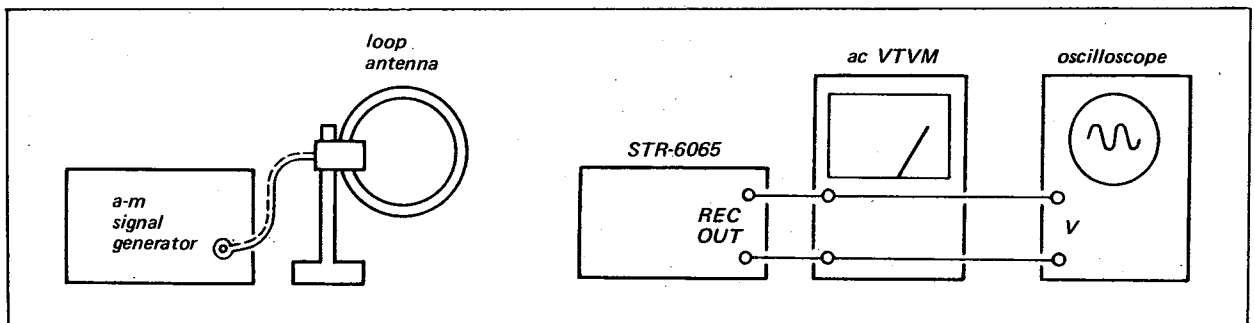

Fig. 3-14. A-m frequency coverage and tracking alignment test setup

Procedure

With the equipment connected as shown in Fig. 3-14, follow the procedures given in Tables 3-4 and 3-5 when performing this alignment with an a-m signal generator.

Off-the-Air Signal Method

Accurate dial calibration, and a frequency-coverage and tracking test can also be performed by utilizing off-the-air local a-m signals. However, before performing the following procedure, be sure that the dial pointer is correctly positioned, as in the Procedure 2-6.

Frequency Coverage Adjustment

Procedure

1. Tune the receiver to the lowest-frequency station in your locality.
Check the dial scale for a calibration accuracy of ± 20 kHz from the carrier frequency. If the

dial calibration error exceeds this limit, turn the local oscillator-coil L304 (see Fig. 3-10) slightly until optimum dial calibration is obtained.

2. Tune the receiver to the highest-frequency station in your locality. If the dial calibration error exceeds ± 30 kHz from the carrier frequency, adjust local-oscillator trimmer-capacitor CT301 (see Fig. 3-10) to obtain maximum calibration accuracy. Repeat the above steps two or three times.

Tracking Adjustment

1. Tune the set to the station whose carrier frequency is closest to 620 kHz and adjust the position of antenna core L904 as shown in Fig. 3-15 to obtain maximum output.
2. Tune the set to the station whose carrier frequency is closest to 1,400 kHz and adjust antenna trimmer CT302 to obtain maximum output. See Fig. 3-10.
3. Repeat the above steps two or three times.

TABLE 3-4. A-M FREQUENCY COVERAGE ALIGNMENT

SSG Coupling	SSG Frequency and Output Level	Tuner Dial Indication	Scope Connection	Adjust	Indication
Loop antenna	530 kHz 400 Hz 30% Mod. 3,000 μ V (70 dB)	530 kHz	REC OUT (J105)	OSC coil L304 See Fig. 3-10	Maximum VTVM reading
Loop antenna	1,600 kHz Same as above	1,600 kHz	Same as above	OSC trimmer CT301 See Fig. 3-10	Same as above

TABLE 3-5. A-M TRACKING ALIGNMENT

SSG Coupling	SSG Frequency and Output Level	Tuner Dial Indication	Scope Connection	Adjust	Indication
Loop antenna	620 kHz 400 Hz 30% Mod. Output level as low as possible	620 kHz	REC OUT (J105)	Position of antenna core L904 See Fig. 3-15	Maximum VTVM reading
Loop antenna	1,400 kHz Same as above	1,400 kHz	Same as above	Antenna trimmer CT302 See Fig. 3-10	Same as above

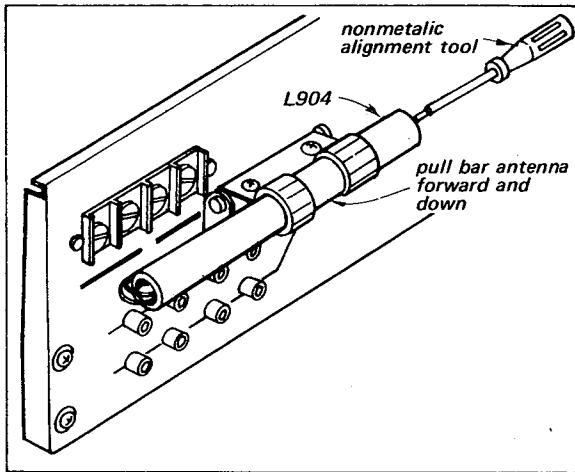

Fig. 3-15. A-m bar antenna core adjustment

3-8. POWER-AMPLIFIER ADJUSTMENT

Note: There are two adjustment items in the power amplifier. One is dc-bias adjustment and the other is dc-balance adjustment. These adjustments should be repeated alternately two or three times after replacing any of the power transistors until the best operation is obtained.

Dc-Bias Adjustment

Serious deficiencies in performance, such as

thermal runaway of power transistors, will result if this adjustment is improperly set.

CAUTION

To avoid accidental power transistor damage, increase the ac line voltage gradually, using a variable transformer, while measuring the voltage across emitter resistor R738 or R788 as shown in Fig. 3-16.

Check to see that the reading does not exceed 25 mV. If it does, turn off the power as soon as possible, then check and repair the trouble in the power-amplifier board.

Test Equipment Required

1. Dc millivoltmeter
2. Variable transformer
3. Screwdriver with 3 mm (1/8") blade

Preparation

1. Remove the top cover as described in Procedure 2-3.
2. Connect the dc millivoltmeter across emitter resistor R738 or R788 as shown in Fig. 3-16.

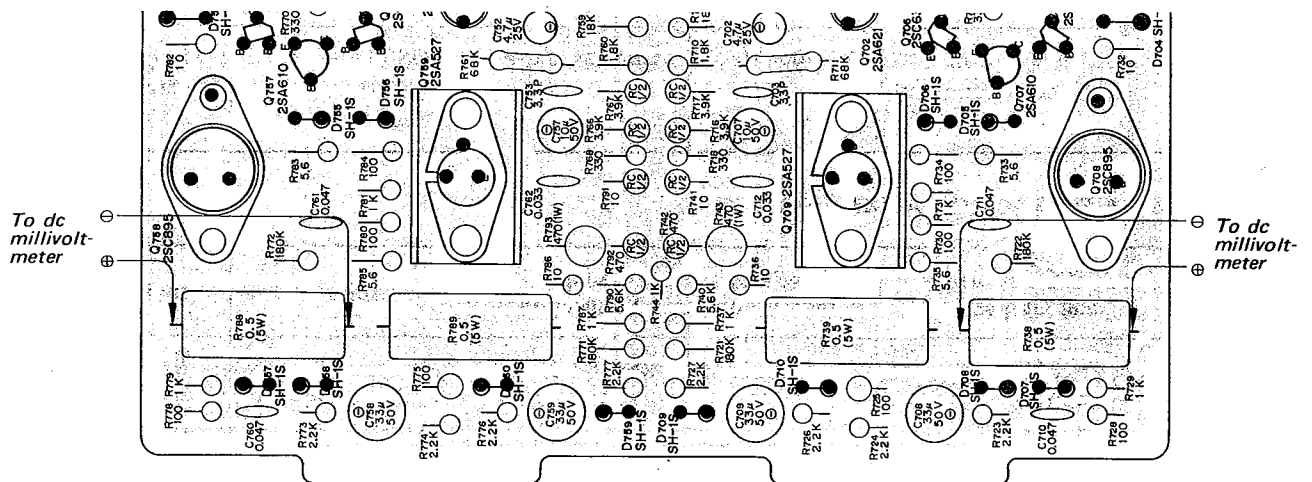

Fig. 3-16. Dc millivoltmeter connection

Procedure

1. Set the semifixed resistors (Fig. 3-17) on the power-amplifier board as follows:

RV702
(L-CH, dc bias) fully counterclockwise

RV752
(R-CH, dc bias) fully clockwise

RV701, RV751
(dc balance) mid-position

2. Set the SPEAKER switch to MAIN.
3. Set the variable transformer for minimum output.
4. Turn the POWER switch ON, and then increase the line voltage up to the rated value.
5. Apply a drop of cement solvent to the RV701, RV702, RV751 and RV752 then wait a few seconds for the cement to dissolve.
6. Adjust RV702 and RV752 to obtain a 25 mV reading on the meter, and then perform the dc-balance adjustment.

Dc-Balance Adjustment

Excessive harmonic distortion at high levels will result if this adjustment is improperly set.

Test Equipment Required

1. Dc null meter or dc millivoltmeter
2. Screwdriver with 3 mm (1/8") blade

Preparation

1. Set the SPEAKER switch to MAIN.
2. Connect the dc null meter or dc millivoltmeter to the MAIN speaker output terminal.

Procedure

1. Turn the POWER switch ON, and then adjust RV701 (RV751) to obtain a 0V reading on the meter.
2. After 10 minutes warm-up, alternately repeat this and the dc bias adjustment two or three times.
3. After completing the adjustment, apply a drop of lock paint to RV701 and RV702 (RV751 and RV752).

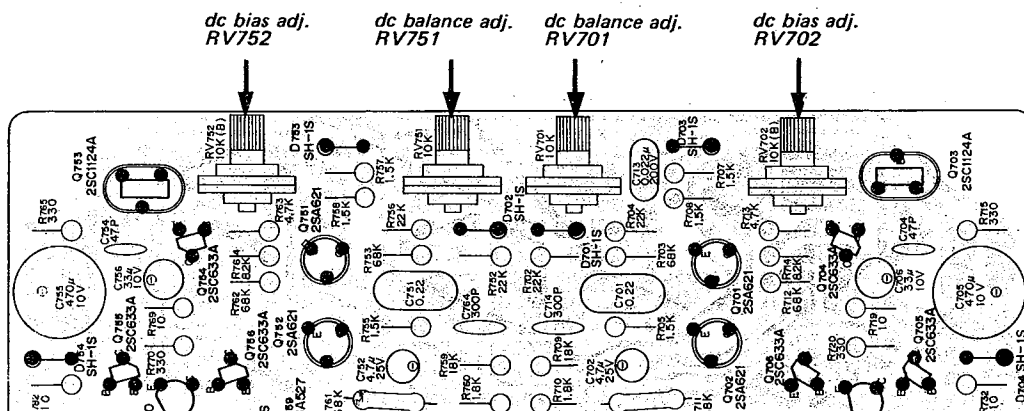

Fig. 3-17. Parts location

**SECTION 4
REPACKING**

The STR-6065's original shipping carton and packing material are the ideal container for shipping the unit. However to secure the maximum pro-

tection, the STR-6065 must be repacked in these materials precisely as before. The proper repacking procedures are shown in Fig. 4-1.

X-37930-04 warranty card ass'y (USA Model only)	3-790-941-11 manual, instruction (General Export Model)
X-44900-02-1 cloth, polishing	3-790-941-31 manual, instruction (USA Model)
1-501-083 ribbon antenna, fm	3-790-941-41 manual, instruction (CANADA Model)
1-506-138-11 phono plug, red	3-792-941 tag, price (CANADA Model only)
1-506-138-12 phono plug, white	3-793-105 list, warranty station (CANADA Model only)
1-506-191 plug, binaural	3-793-183 card, inspection
3-701-020 bag, polyethylene	3-796-836 SONY Hi-Fi warranty (CANADA Model only)
3-701-026 tack label	4-802-201 bag, polyethylene (CANADA Model only)

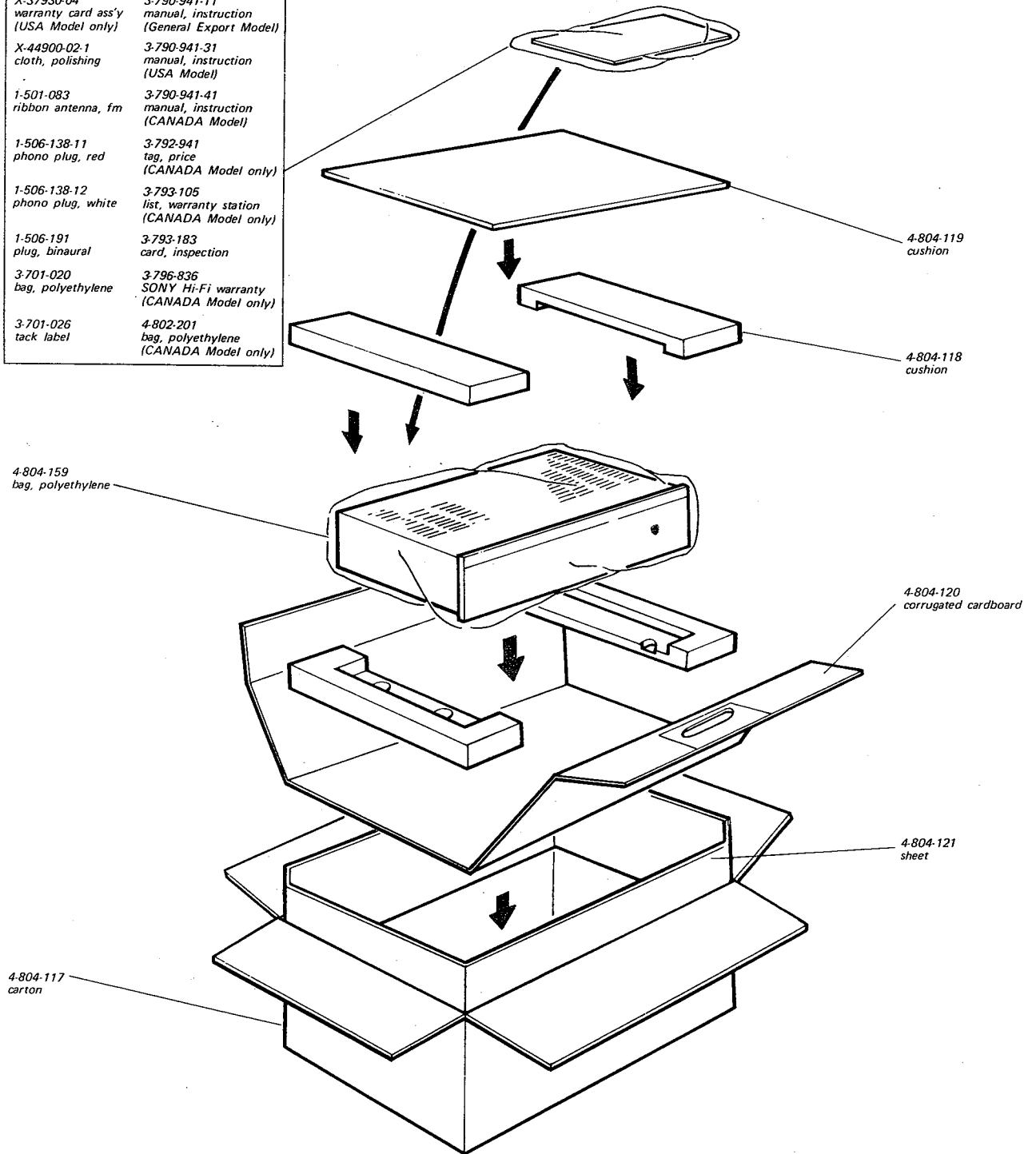
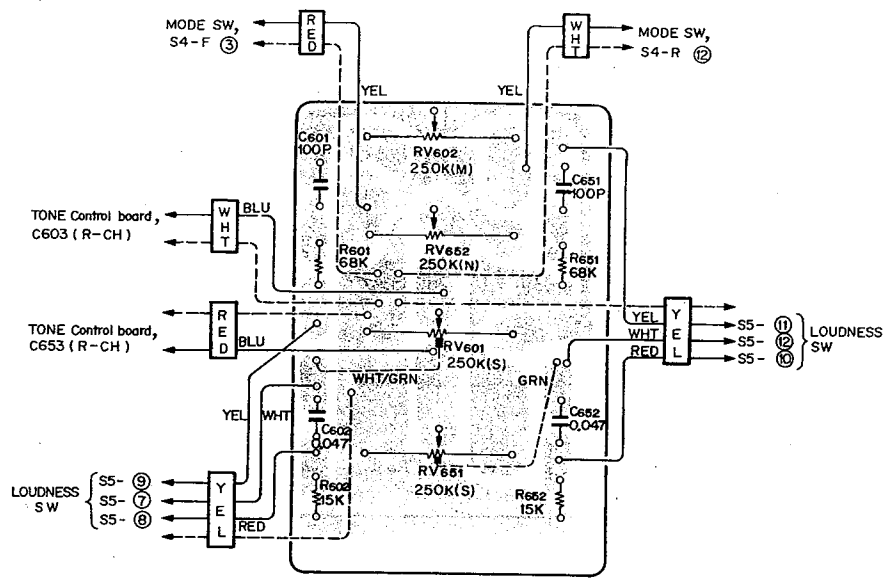

Fig. 4-1. Repacking

**SECTION 5
DIAGRAMS**

MOUNTING DIAGRAM --Loudness Control Board --

-- Conductor Side --



-- Component Side --

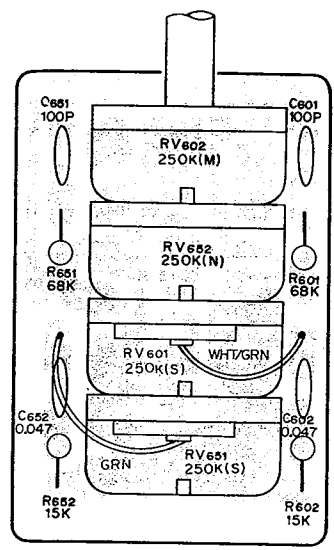

MOUNTING DIAGRAM – Equalizer Board –

– Conductor Side –

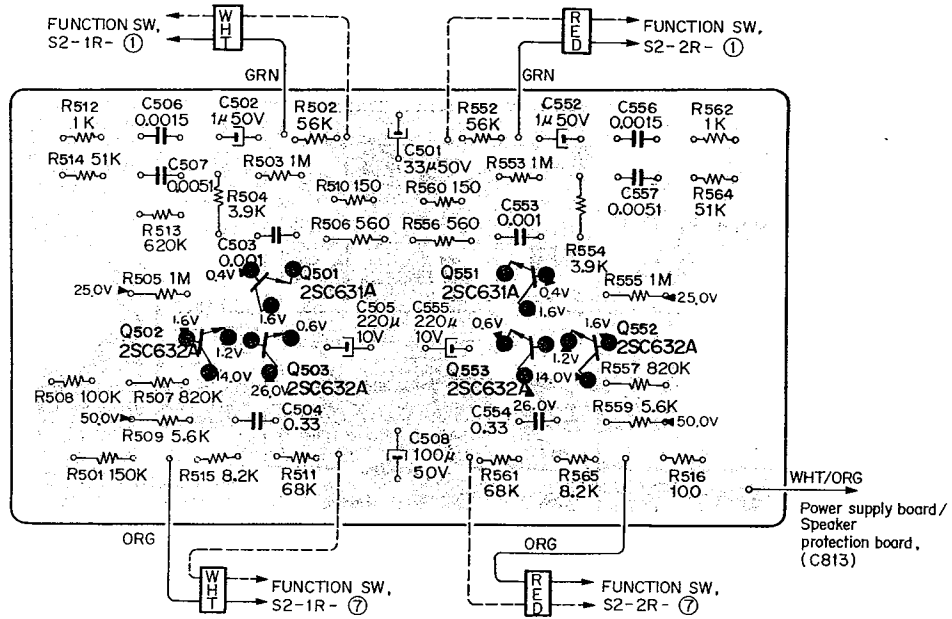

– Component Side –

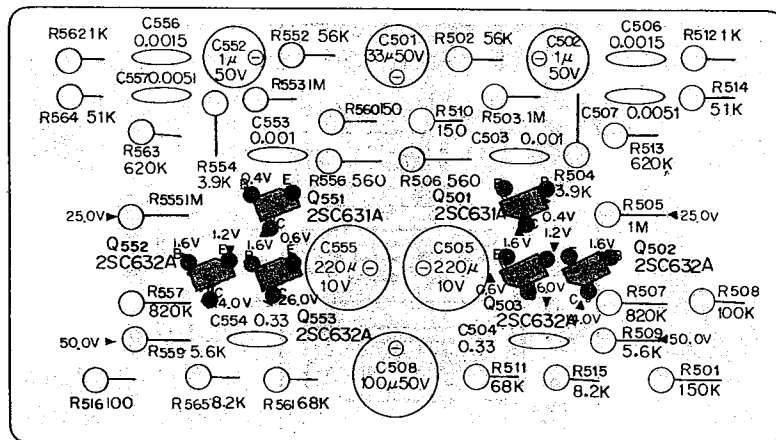

MOUNTING DIAGRAM – Fm Front End –

– Conductor Side –

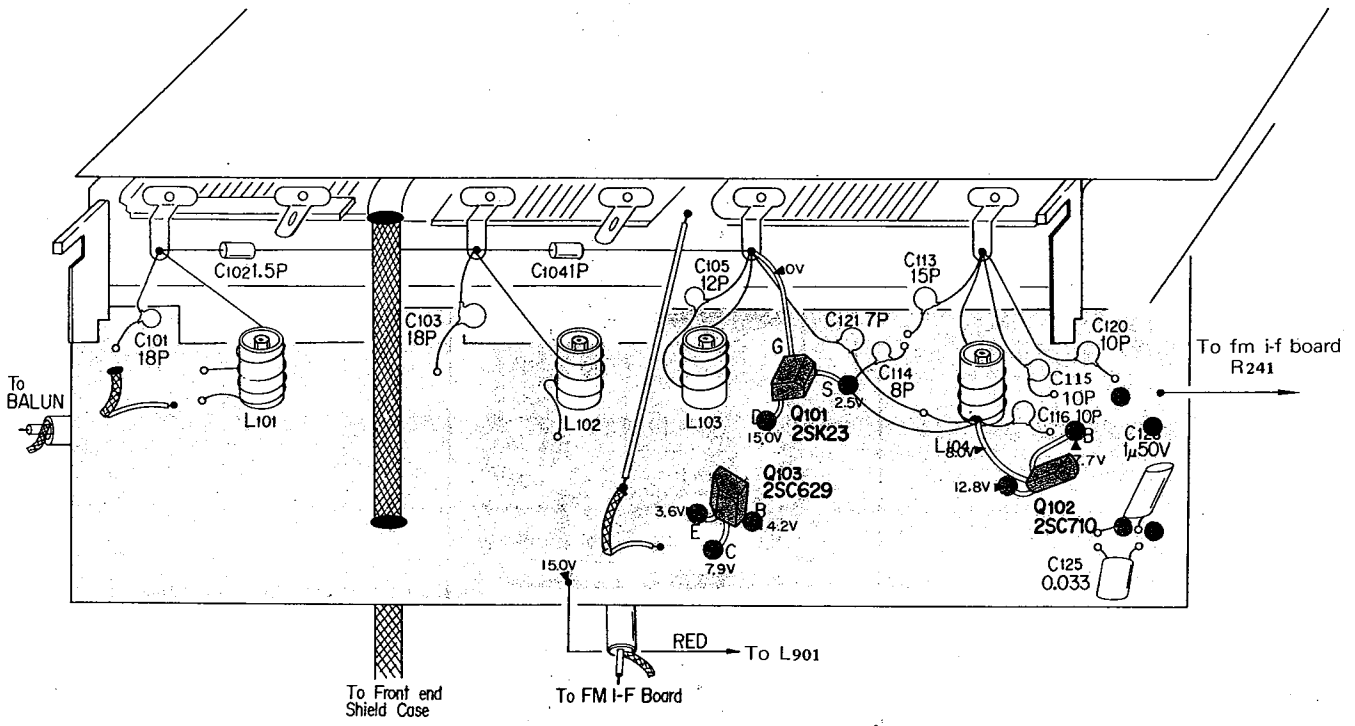

– Component Side –

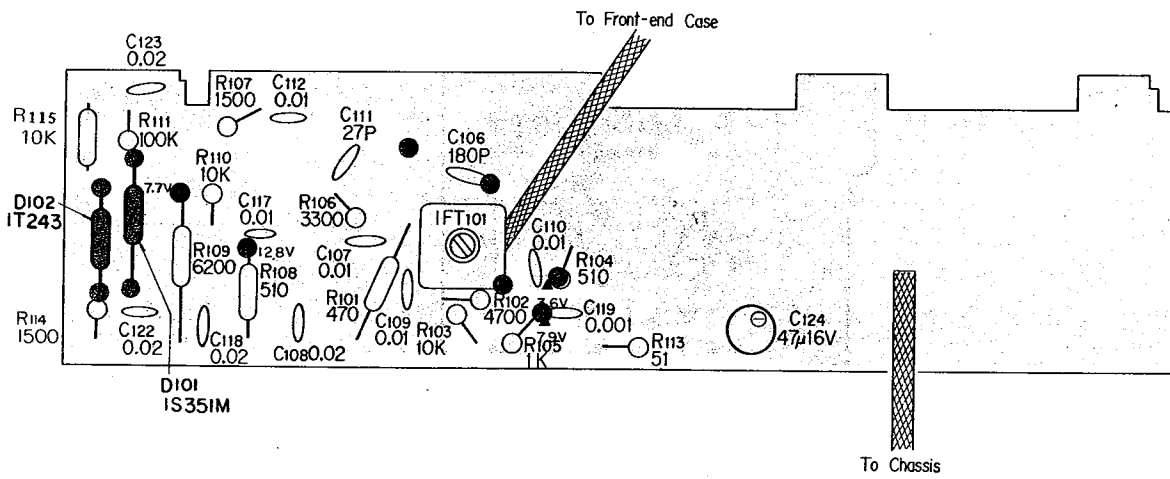

MOUNTING DIAGRAM – Fm I-f Board –

– Conductor Side –

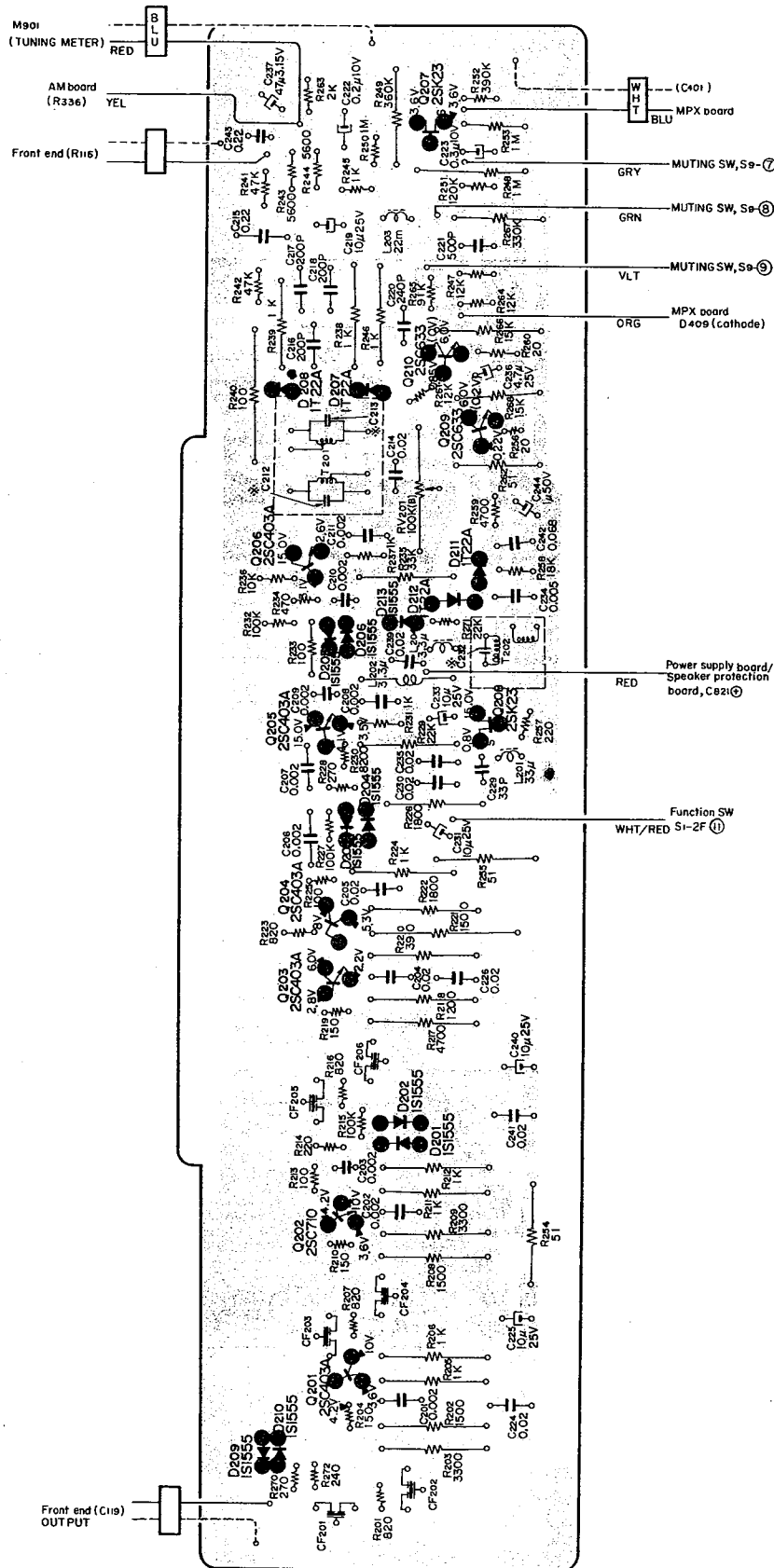

() : MUTING Operation

MOUNTING DIAGRAM - MPX Board -

- Conductor Side -

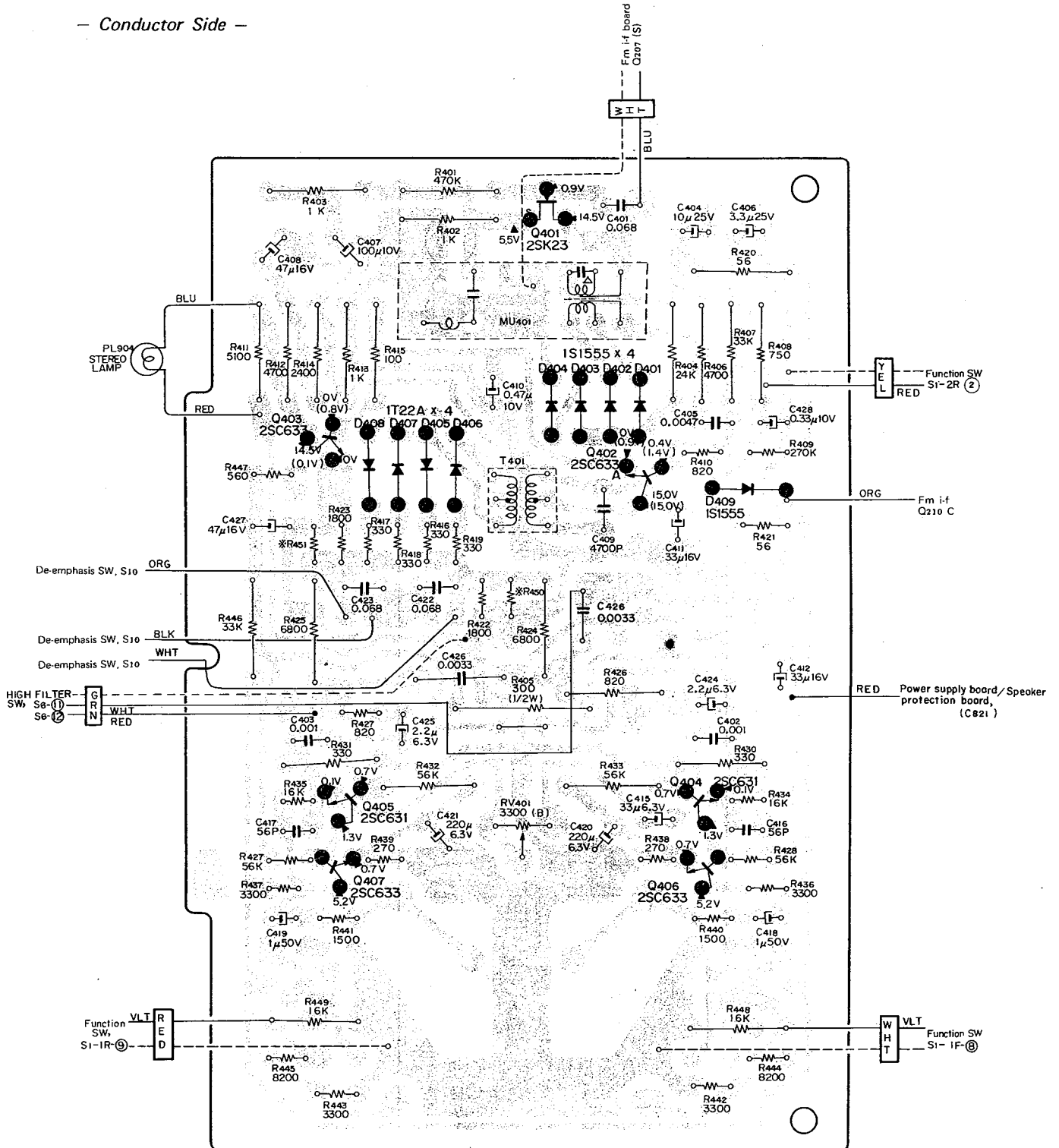

() ; Stereo Operation

- Component Side -

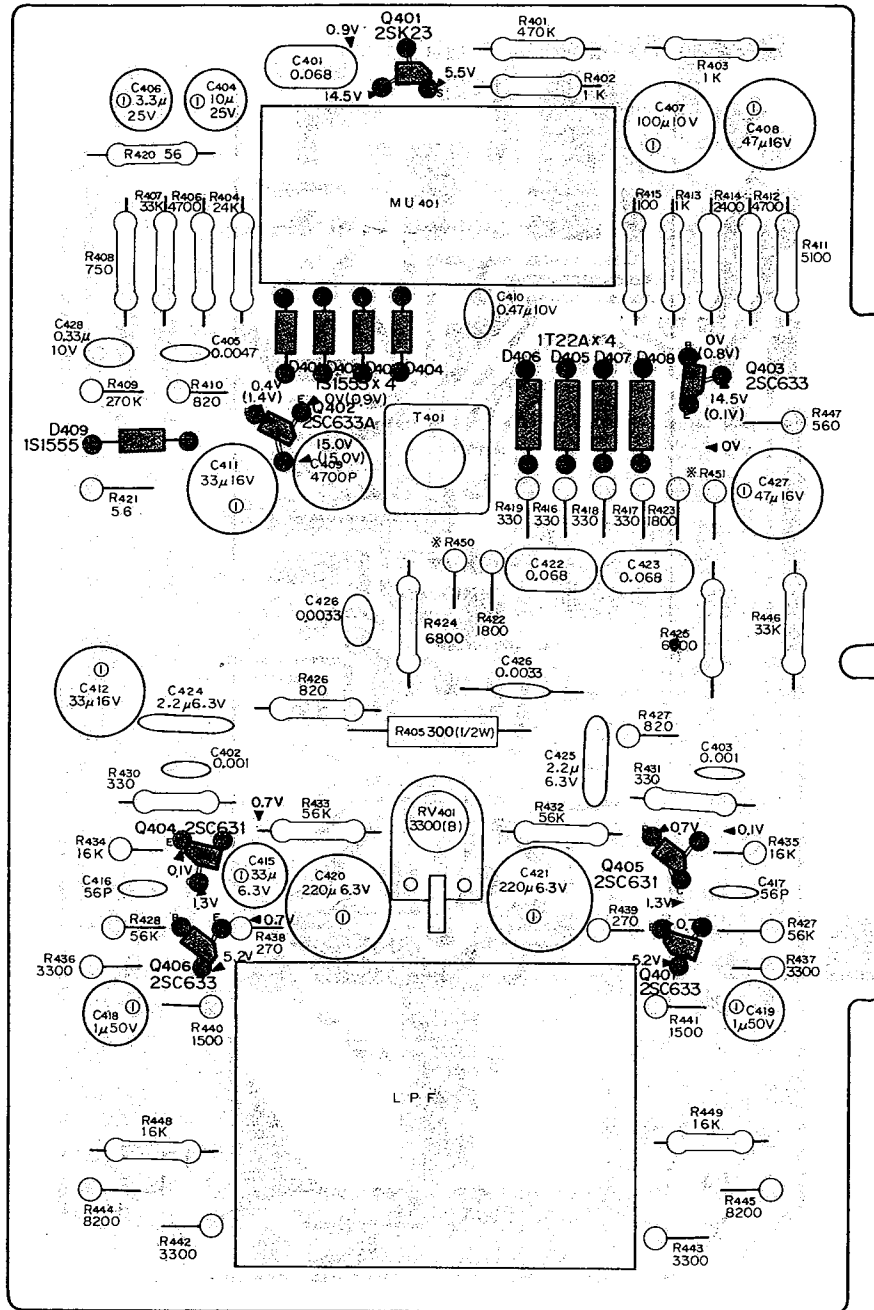

() ; Stereo Operation

MOUNTING DIAGRAM - A-m I-f Board -

- Conductor Side -

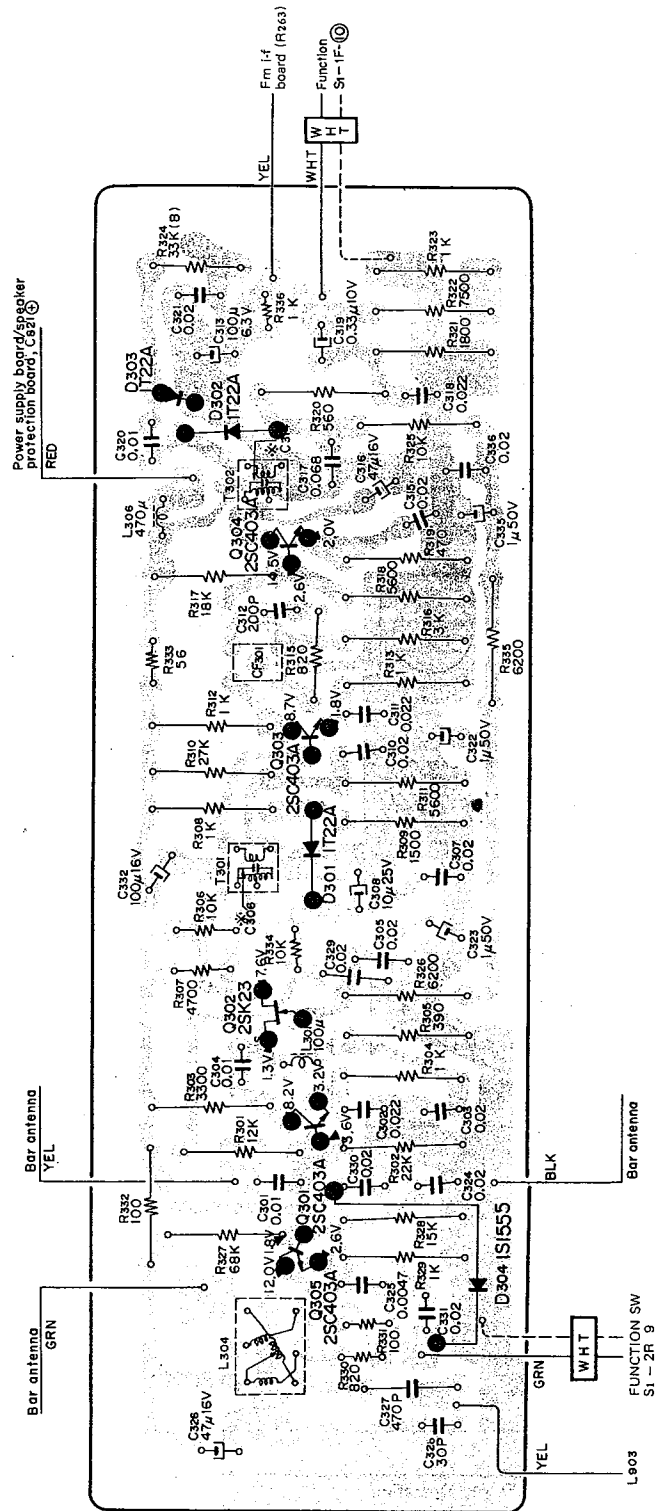

- Component Side -

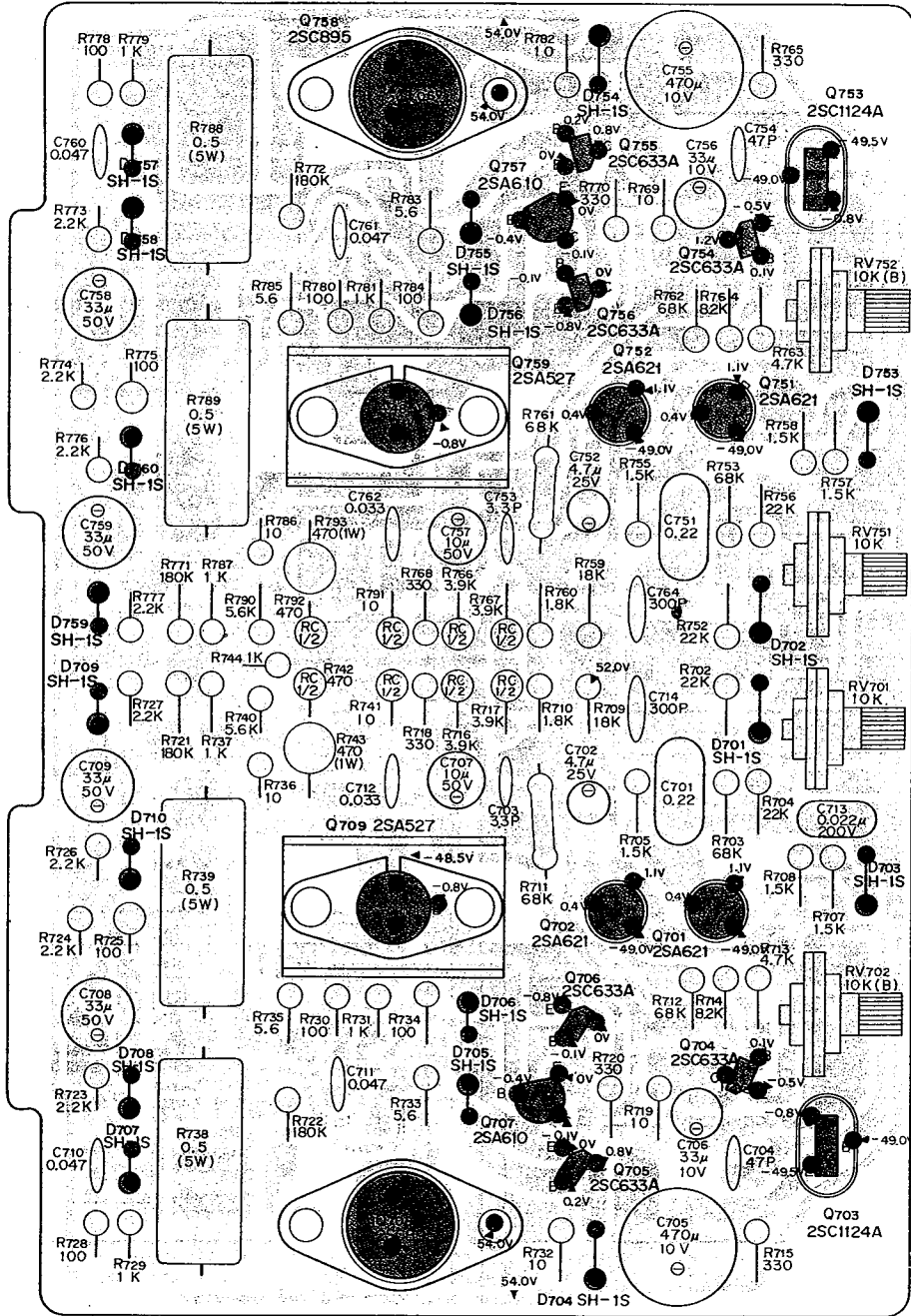

MOUNTING DIAGRAM - Power Supply Board -

- Conductor Side -

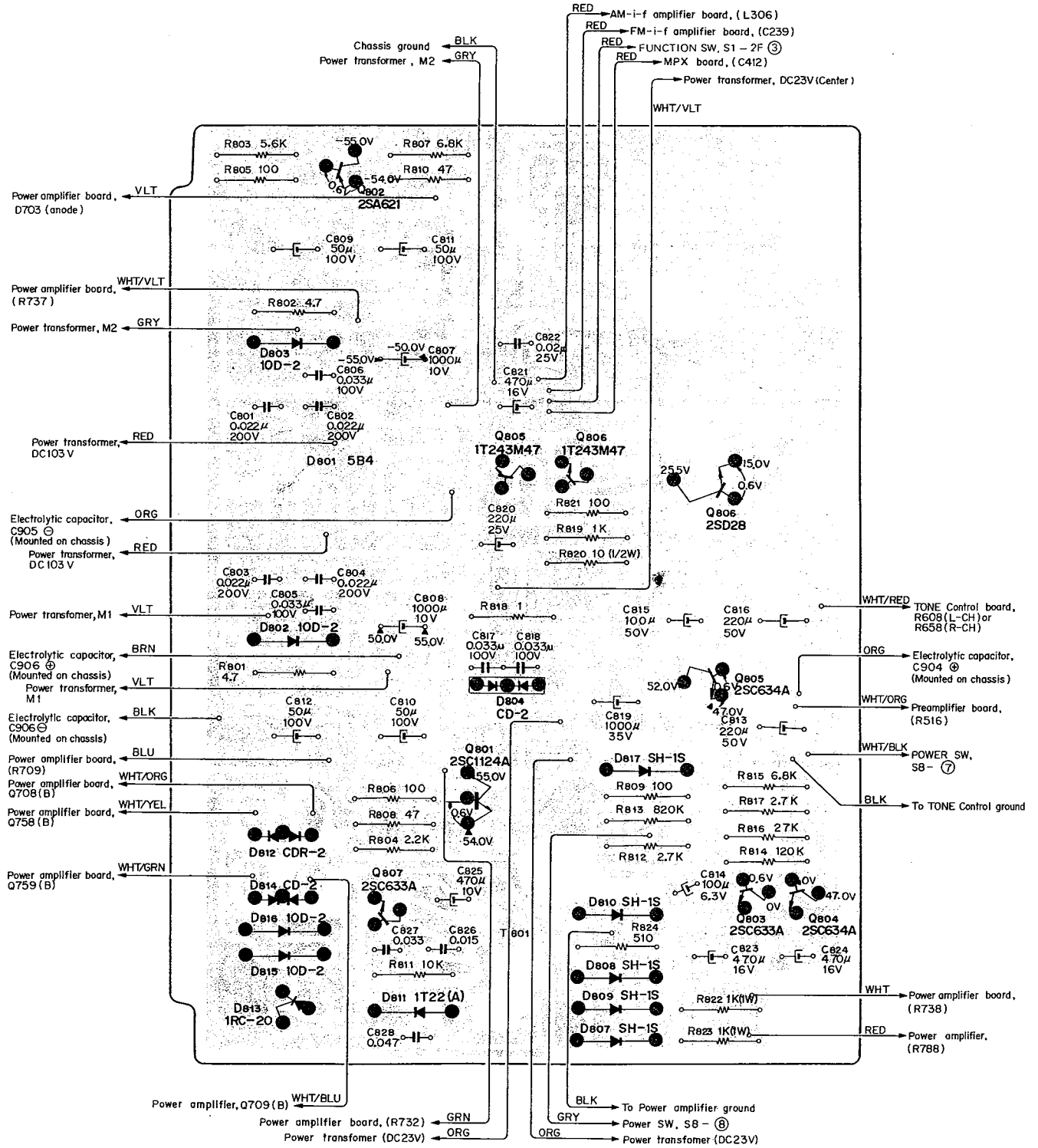

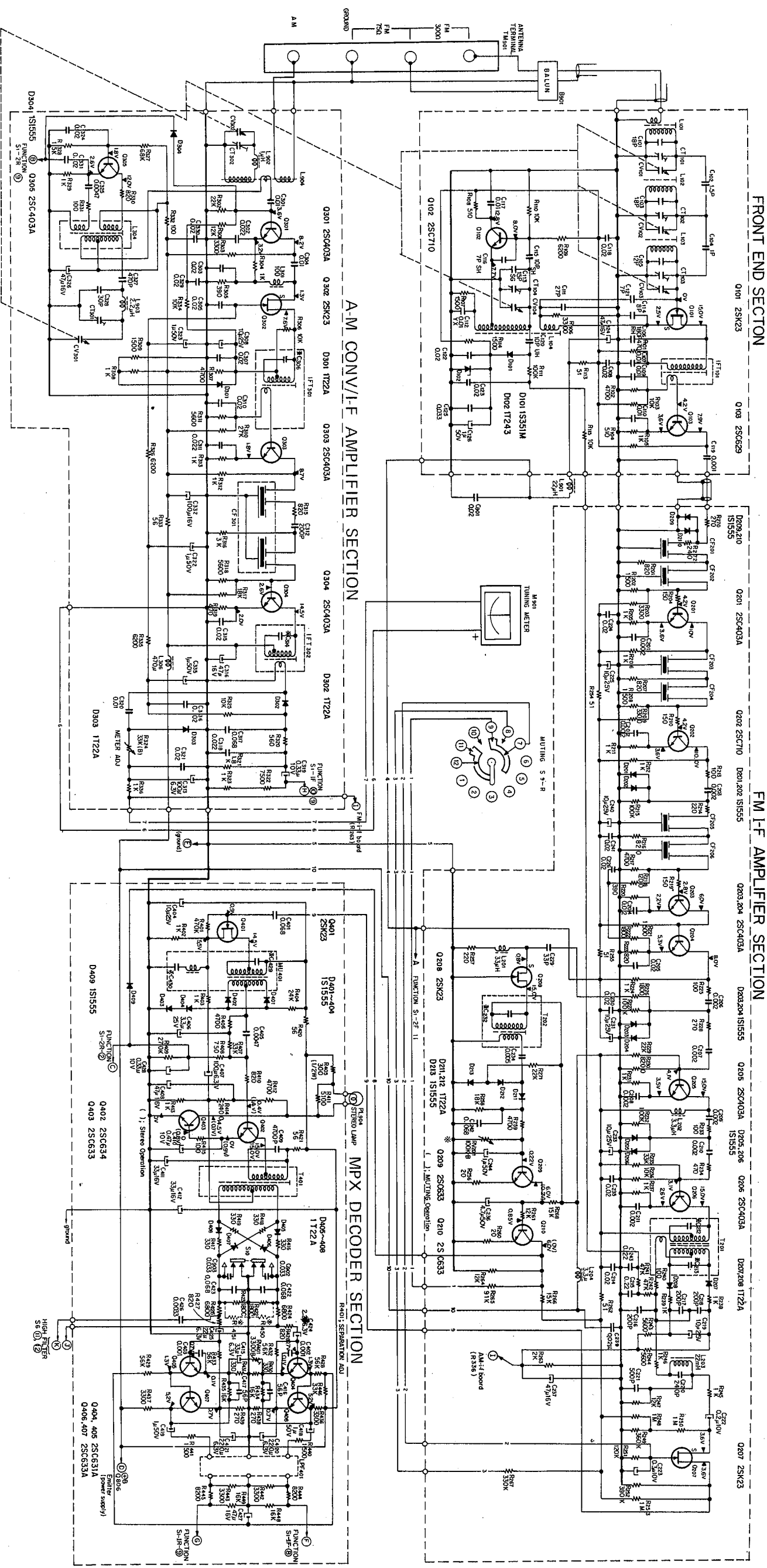

Ref. No.	Description	Position
S9	MUTING SW	ON
S10	DE-EMPHASIS SW	75 μsec

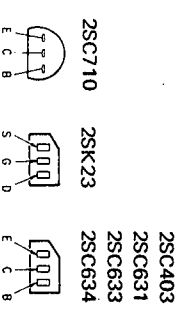
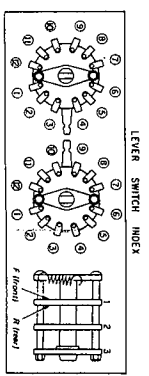

Note:
 All resistance values are in ohms, k = 1,000, M = 1,000k
 All capacitance values are in μF except as indicated with p.
 All voltages represent an average value and should hold
 within ±20%.
 All voltages are dc measured with a VOM which has an
 input impedance of 20k ohm/volt. No signal in.

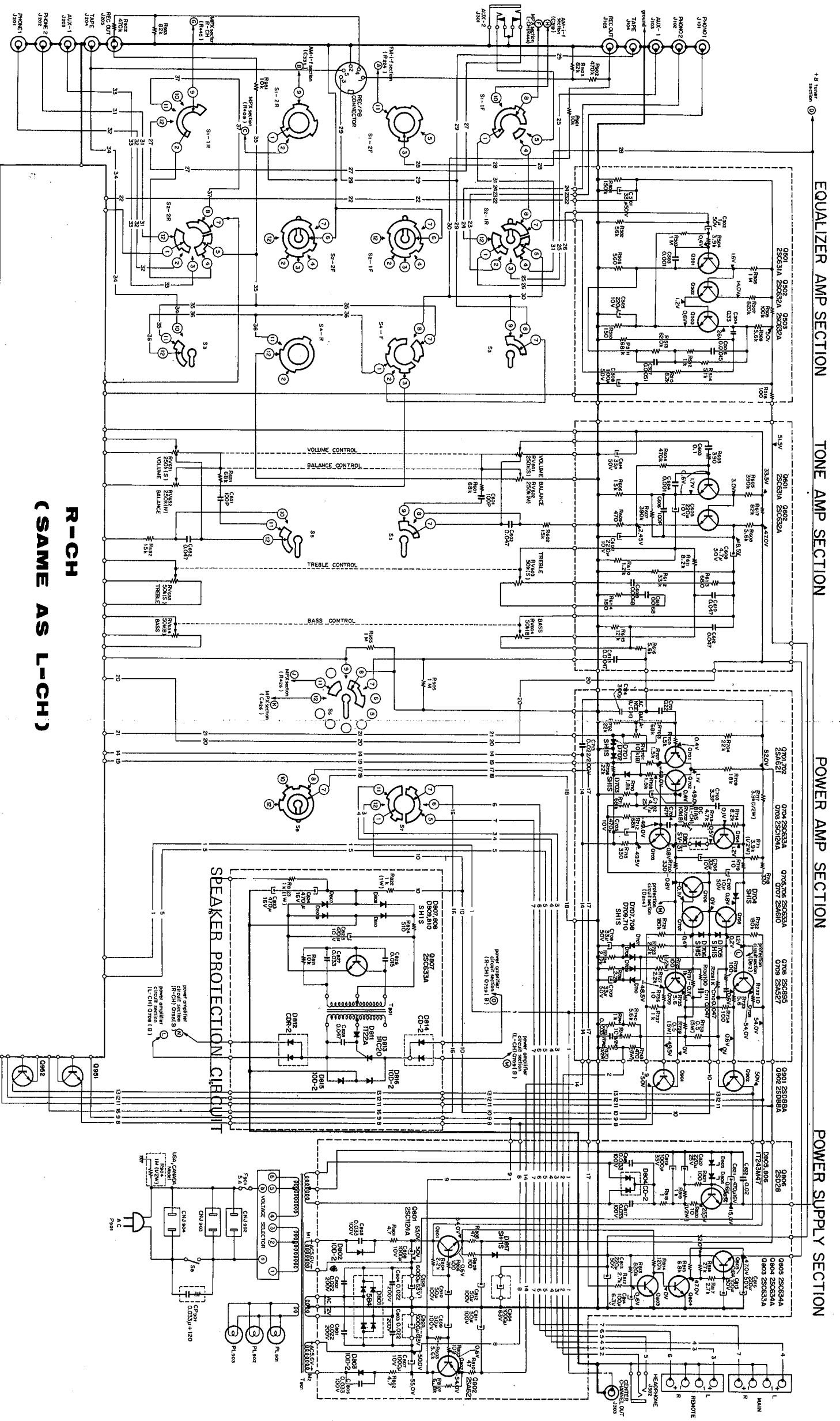

R-CH
(SAME AS L-CH)

Ref. No.	Description	Position	Ref. No.	Description	Position
S1	FUNCTION (1) (FM AUTO STEREO - FM MONO - AM - PHONO-2 - AUX-2)	AUTO STEREO	S5	LOUDNESS SW	ON
S2	FUNCTION (2) SW (AUX-1 - FUNCTION (1) - PHONO-1)	FUNCTION (1)	S6	HIGH FILTER	OFF
S3	MONITOR SW (SOURCE - TAPE)	SOURCE	S7	SPEAKER SW (REMOTE - OFF - MAIN - BOTH)	BOTH
S4	MODE SW (REVERSE - STEREO - L+R - LEFT - RIGHT)	STEREO	S8	POWER SW	OFF

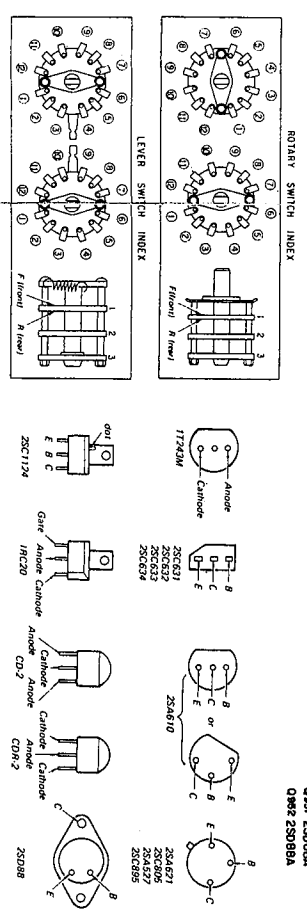

Note:
All resistance values are in ohms, k = 1,000, M = 1,000k.
All capacitance values are in μ F except as indicated with p.
All voltages represent an average value and should hold
within $\pm 20\%$.
All voltages are dc - measured with a VOM which has an
input impedance of 20k Ohms/volt. No signal in.

EXPLODED VIEW

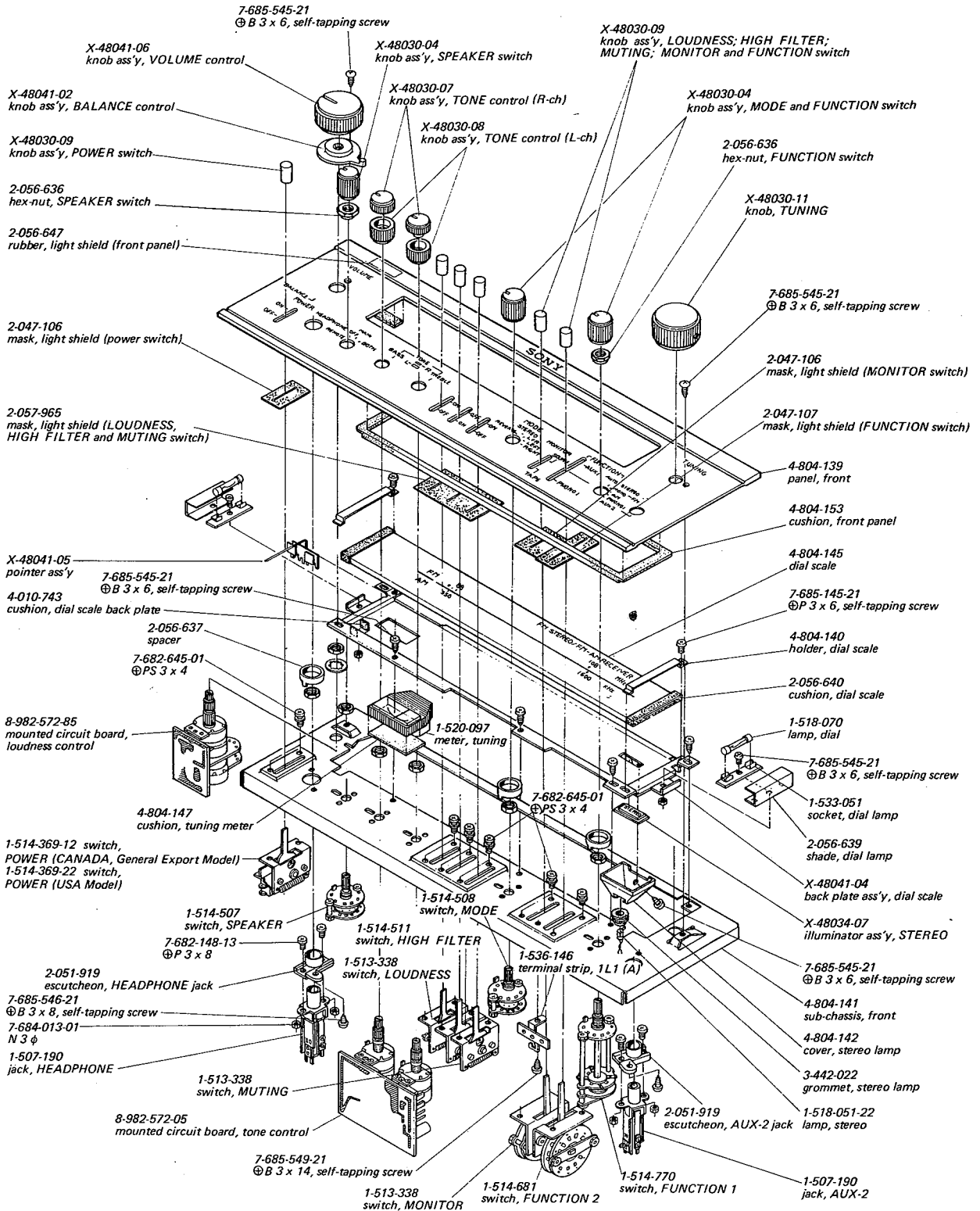

DETAIL "A"

EXPLODED VIEW

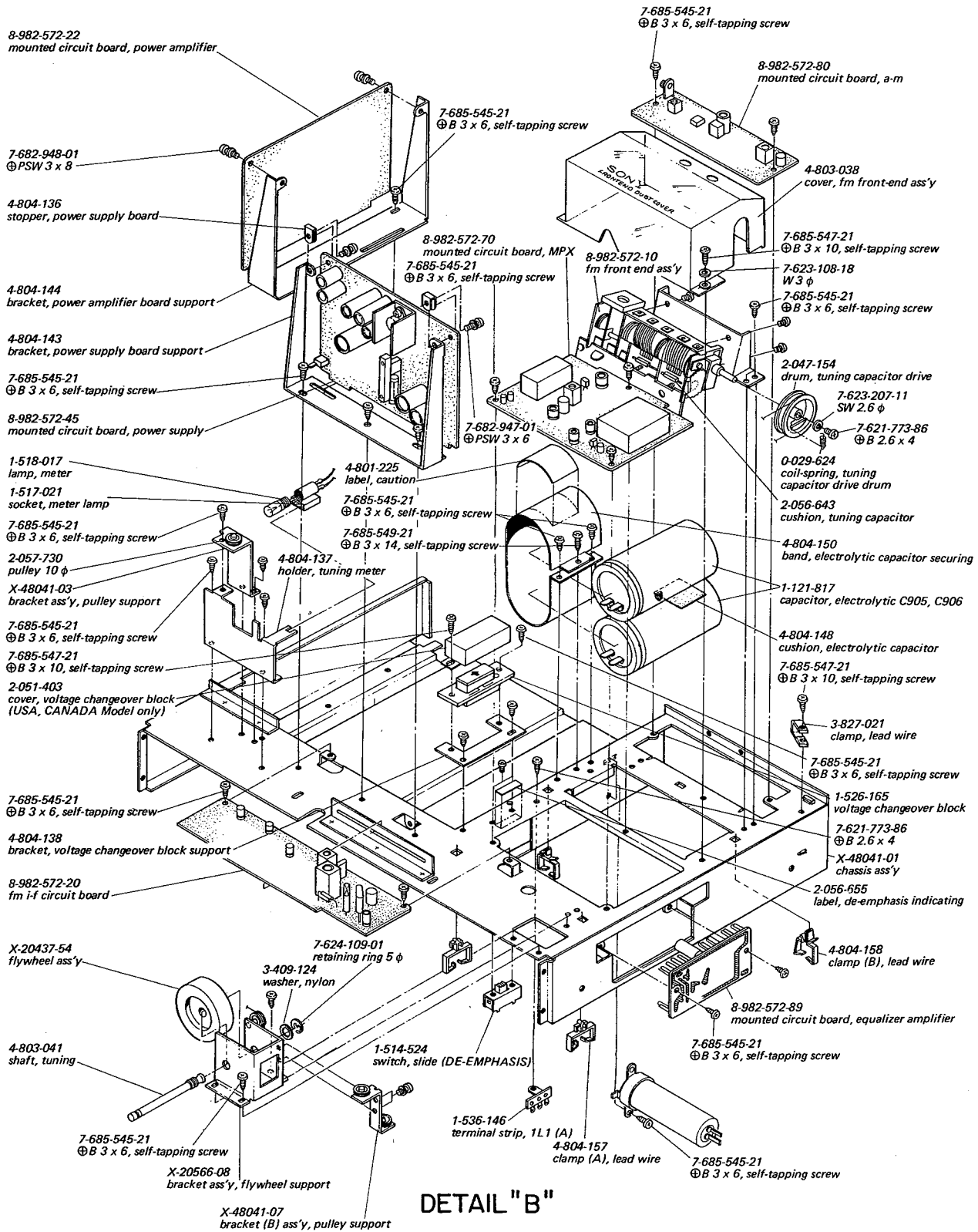

DETAIL "B"

EXPLODED VIEW

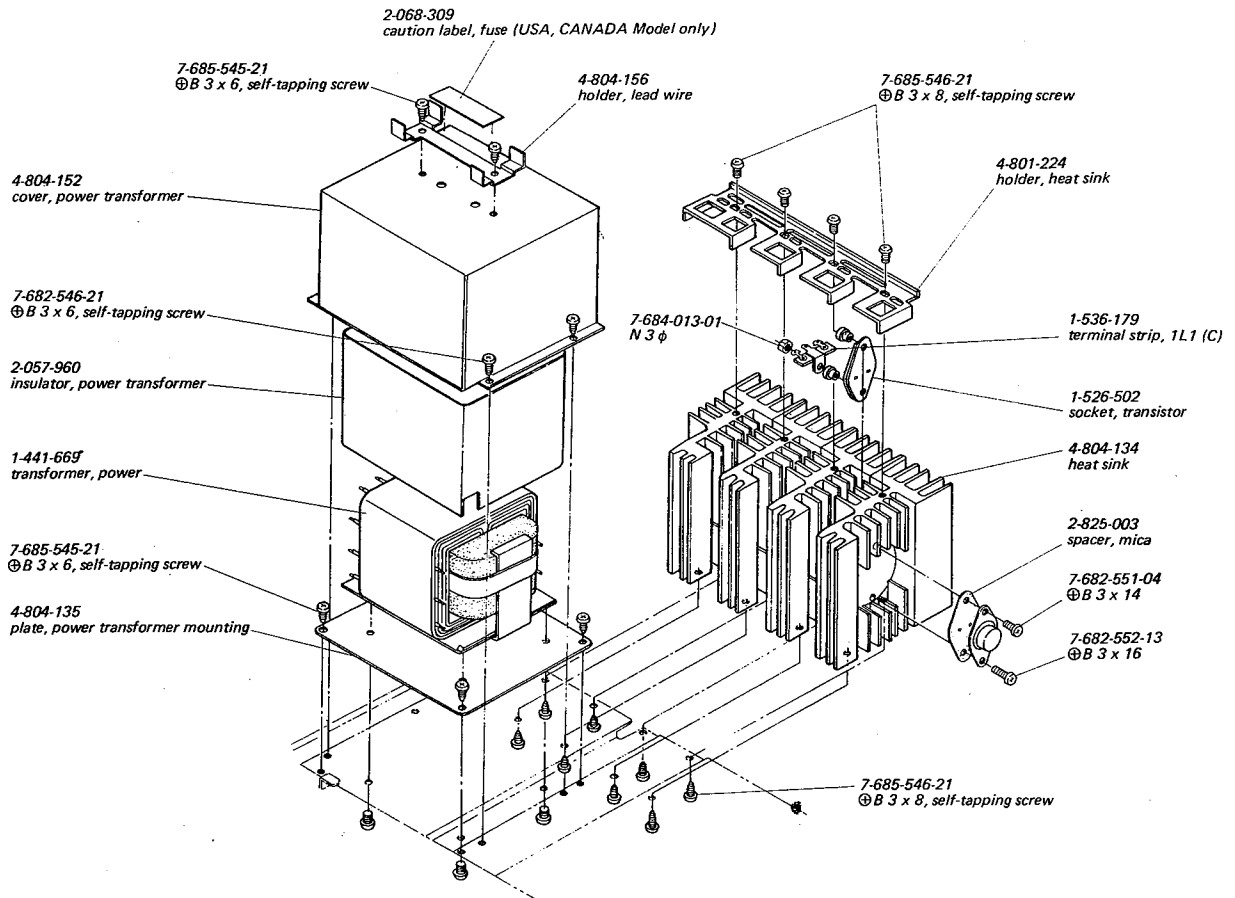

1-534-487 cord, power (General Export Model)
1-534-526 cord, power (USA, CANADA Model)

DETAIL "C"

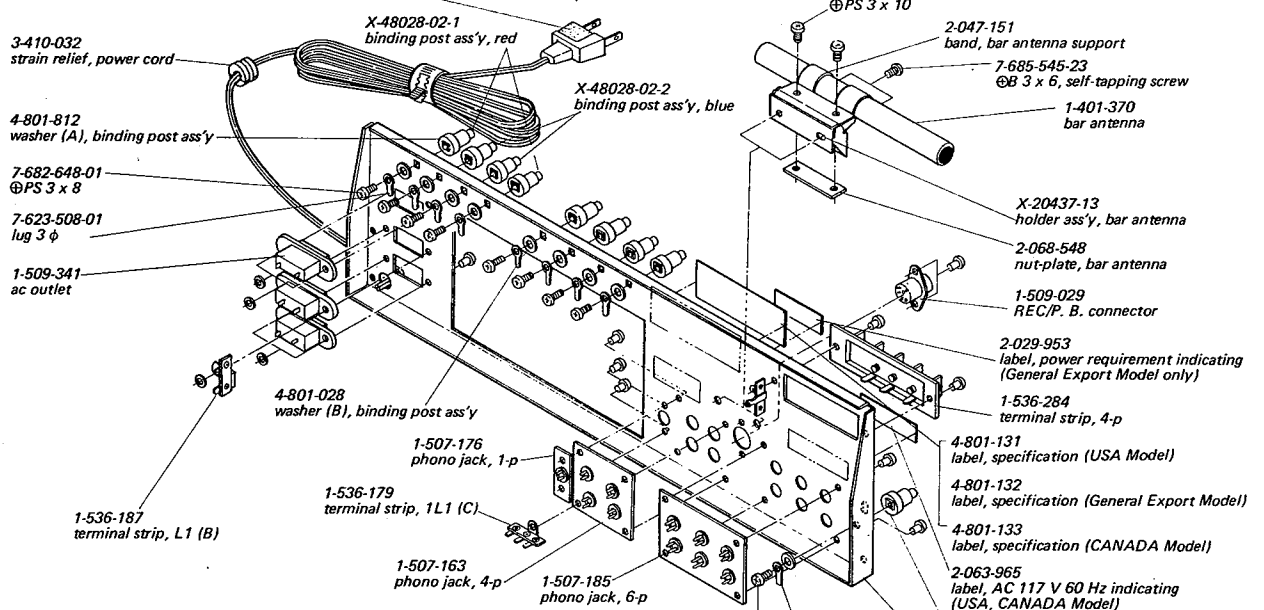

DETAIL "D"

SECTION 7

ELECTRICAL PARTS LIST

<u>Ref. No.</u>	<u>Part No.</u>	<u>Description</u>	<u>Ref. No.</u>	<u>Part No.</u>	<u>Description</u>
MOUNTED CIRCUIT BOARDS			D803		diode, 10D2
			D804		diode, CD2
8-982-572-05		tone control circuit board	D805		diode, 1T243M
8-982-572-85		loudness control circuit board	D806		diode, 1T243M
8-982-572-22		power amplifier circuit board	D807		diode, SH1S
8-982-572-45		power supply circuit board	D808		diode, SH1S
8-982-572-89		equalizer amplifier circuit board	D809		diode, SH1S
8-982-572-70		MPX circuit board	D810		diode, SH1S
8-982-572-80		a-m circuit board	D811		diode, 1T22A
8-982-572-20		fm i-f circuit board	D812		diode, CDR2
8-982-572-10		fm front-end ass'y, FAF-013BW	D813		SCR, 1RC20
			D814		diode, CD2
			D815		diode, 10D2
			D816		diode, 10D2
			D817		diode, SH1S
			D901 (D951)		diode, SV-31
SEMICONDUCTORS			Q101		FET, 2SK23
D101		diode, 1S351	Q102		transistor, 2SC710
D102		diode, 1T243	Q103		transistor, 2SC629
D201		diode, 1S1555	Q201		transistor, 2SC403A
D202		diode, 1S1555	Q202		transistor, 2SC710
D203		diode, 1S1555	Q203		transistor, 2SC403A
D204		diode, 1S1555	Q204		transistor, 2SC403A
D205		diode, 1S1555	Q205		transistor, 2SC403A
D206		diode, 1S1555	Q206		transistor, 2SC403A
D207		diode, 1T22A	Q207		FET, 2SK23
D208		diode, 1T22A	Q208		FET, 2SK23
D209		diode, 1S1555	Q209		transistor, 2SC633A
D210		diode, 1S1555	Q210		transistor, 2SC633A
D211		diode, 1T22A	Q301		transistor, 2SC403A
D212		diode, 1T22A	Q302		FET, 2SK23
D213		diode, 1S1555	Q303		transistor, 2SC403A
D301		diode, 1T22A	Q304		transistor, 2SC403A
D302		diode, 1T22A	Q305		transistor, 2SC403A
D303		diode, 1T22A	Q401		FET, 2SK23
D304		diode, 1S1555	Q402		transistor, 2SC633A
D401		diode, 1S1555	Q403		transistor, 2SC633A
D402		diode, 1S1555	Q404		transistor, 2SC631A
D403		diode, 1S1555	Q405		transistor, 2SC631A
D404		diode, 1S1555	Q406		transistor, 2SC633A
D405		diode, 1T22A	Q407		transistor, 2SC633A
D406		diode, 1T22A	Q501 (Q551)		transistor, 2SC631A
D407		diode, 1T22A	Q502 (Q552)		transistor, 2SC632A
D408		diode, 1T22A	Q503 (Q553)		transistor, 2SC632A
D409		diode, 1S1555	Q601 (Q651)		transistor, 2SC631A
D701 (D751)		diode, SH1S	Q602 (Q652)		transistor, 2SC632A
D702 (D752)		diode, SH1S	Q701 (Q751)		transistor, 2SA621
D703 (D753)		diode, SH1S	Q702 (Q752)		transistor, 2SA621
D704 (D754)		diode, SH1S	Q703 (Q753)		transistor, 2SC1124A
D705 (D755)		diode, SH1S	Q704 (Q754)		transistor, 2SC633A
D706 (D756)		diode, SH1S	Q705 (Q755)		transistor, 2SC633A
D707 (D757)		diode, SH1S			
D708 (D758)		diode, SH1S			
D709 (D759)		diode, SH1S			
D710 (D760)		diode, SH1S			
D801		diode, 5B4			
D802		diode, 10D2			

Ref. No.	Part No.	Description	Ref. No.	Part No.	Description
Q706 (Q756)		transistor, 2SC633A	C115	1-101-978	10p ±5% 50V ceramic
Q707 (Q757)		transistor, 2SA610	C116	1-102-875	7p ±5% 50V ceramic
Q708 (Q758)		transistor, 2SC895	C117	1-101-072	0.01 ±80% 25V ceramic
Q709 (Q759)		transistor, 2SA527	C118	1-101-073	0.02 ±80% 25V ceramic
Q801		transistor, 2SC1124A	C119	1-101-918	0.001 ±80% 25V ceramic
Q802		transistor, 2SA621	C120	1-101-978	10p ±5% 50V ceramic
Q803		transistor, 2SC633A	C121	1-101-957	7p ±0.5p 50V ceramic
Q804		transistor, 2SC634A	C122	1-101-073	0.02 ±80% 25V ceramic
Q805		transistor, 2SC634A	C123	1-101-073	0.02 ±80% 25V ceramic
Q806		transistor, 2SD28	C124	1-121-353	47 ±100% 16V electrolytic
Q807		transistor, 2SC633A	C125	1-105-679-12	0.033 ±10% 50V mylar
Q901 (Q951)		transistor, 2SD88A	C126	1-121-391	1 ±150% 50V electrolytic
Q902 (Q952)		transistor, 2SD88A			

TRANSFORMERS, COILS AND INDUCTORS

B101	1-417-014	balun
IFT101	1-403-295	IFT, fm 10.7 MHz
IFT301	1-403-152	IFT, a-m 455 kHz
IFT302	1-403-128	IFT, a-m 455 kHz
L101	1-401-351	coil, fm antenna
L102	1-425-446	coil, fm rf
L103	1-425-446	coil, fm rf
L104	1-405-377	coil, fm osc
L201	1-407-163	inductor, micro 33μH
L202	1-407-184	inductor, micro 3.3μH
L203	1-407-408	inductor, micro 22 mH
L204	1-407-184	inductor, micro 3.3μH
L301	1-407-169	inductor, micro 100μH
L304	1-405-359	coil, a-m osc
L306	1-407-177	inductor, micro 470μH
L901	1-407-161	inductor, micro 22μH
L902	1-407-178	inductor, micro 1.0μH
L903	1-407-182	inductor, micro 2.2μH
L904	1-401-370	bar antenna, a-m
MU401	1-425-548	MPX unit
T201	1-403-291	transformer, discriminator 10.7 MHz
T202	1-403-299	IFT, fm 10.7 MHz
T401	1-425-260	transformer, switching 38 kHz
T801	1-433-132	transformer, osc.
T901	1-441-669	transformer, power

CAPACITORS

All capacitance values are in μF except as indicated with p, which means μμF.

C101	1-101-862	18p ±5% 50V ceramic
C102	1-101-938	1.5p ±10% 500V ceramic
C103	1-101-862	18p ±5% 50V ceramic
C104	1-101-937	1p ±10% 500V ceramic
C105	1-101-961	12p ±5% 50V ceramic
C106	1-102-985	180p ±5% 50V ceramic
C107	1-101-072	0.01 ±80% 25V ceramic
C108	1-101-073	0.02 ±80% 25V ceramic
C109	1-101-072	0.01 ±80% 25V ceramic
C110	1-101-072	0.01 ±80% 25V ceramic
C111	1-101-869	27p ±5% 50V ceramic
C112	1-102-077	0.01 ±20% 50V ceramic
C113	1-101-873	15p ±5% 50V ceramic
C114	1-101-958	8p ±0.5p 50V ceramic
C201	1-101-919	0.002 ±80% 25V ceramic
C202	1-101-919	0.002 ±80% 25V ceramic
C203	1-101-919	0.002 ±80% 25V ceramic
C204	1-101-073	0.02 ±80% 25V ceramic
C205	1-101-073	0.02 ±80% 25V ceramic
C206	1-101-919	0.002 ±80% 25V ceramic
C207	1-101-919	0.002 ±80% 25V ceramic
C208	1-101-919	0.002 ±80% 25V ceramic
C209	1-101-919	0.002 ±80% 25V ceramic
C210	1-101-919	0.002 ±80% 25V ceramic
C211	1-101-919	0.002 ±80% 25V ceramic
C212		included in T201
C213		included in T201
C214	1-101-073	0.02 ±80% 25V ceramic
C215	1-105-689-12	0.22 ±10% 50V mylar
C216	1-101-030	200p ±5% 50V ceramic
C217	1-101-030	200p ±5% 50V ceramic
C218	1-101-030	200p ±5% 50V ceramic
C219	1-121-398	10 ±100% 25V electrolytic
C220	1-107-140	240p ±10% 50V silvered mica
C221	1-101-424	500p ±20% 250V ceramic
C222	1-127-020	0.22 ±20% 10V electrolytic (aluminum)
C223	1-127-021	0.33 ±20% 10V electrolytic (aluminum)
C224	1-101-073	0.02 ±80% 25V ceramic
C225	1-121-398	10 ±100% 25V electrolytic
C226	1-101-073	0.02 ±80% 25V ceramic
C229	1-101-872	33p ±5% 50V ceramic
C230	1-101-073	0.02 ±80% 25V ceramic
C231	1-121-398	10 ±100% 25V electrolytic
C232		included in T202
C233	1-121-398	10 ±100% 25V electrolytic
C234	1-101-904	0.005 ±80% 50V ceramic
C235	1-101-073	0.02 ±80% 25V ceramic
C236	1-121-398	4.7 ±150% 50V electrolytic
C237	1-121-409	47 ±100% 16V electrolytic
C239	1-101-073	0.02 ±80% 25V ceramic
C240	1-121-398	10 ±100% 25V electrolytic
C241	1-101-073	0.02 ±80% 25V ceramic
C242	1-105-683-12	0.068 ±10% 50V mylar
C243	1-105-689-12	0.22 ±10% 50V mylar
C244	1-121-391	1 ±150% 50V electrolytic
C301	1-101-072	0.01 ±80% 25V ceramic
C302	1-105-837-12	0.022 ±20% 50V mylar
C303	1-101-073	0.02 ±80% 25V ceramic
C304	1-101-072	0.01 ±80% 25V ceramic
C305	1-101-073	0.02 ±80% 25V ceramic

<i>Ref. No.</i>	<i>Part No.</i>	<i>Description</i>			<i>Ref. No.</i>	<i>Part No.</i>	<i>Description</i>		
C306		included in IFT301			C502 (C552)	1-121-391	1	$\pm 150\%$	50V electrolytic
C307	1-101-073	0.02	$\pm 80\%$	25V ceramic	C503 (C553)	1-105-661-12	0.001	$\pm 10\%$	50V mylar
C308	1-121-398	10	$\pm 100\%$	25V electrolytic	C504 (C554)	1-105-691-12	0.33	$\pm 10\%$	50V mylar
C310	1-101-073	0.02	$\pm 80\%$	25V ceramic	C505 (C555)	1-121-420	220	$\pm 100\%$	10V electrolytic
C311	1-105-837-12	0.022	$\pm 20\%$	50V mylar	C506 (C556)	1-106-005-12	0.0015	$\pm 5\%$	50V mylar
C312	1-103-608	200p	$\pm 5\%$	50V styrol	C507 (C557)	1-106-018-12	0.0051	$\pm 5\%$	50V mylar
C313	1-121-413	100	$\pm 100\%$	6.3V electrolytic	C508	1-121-417	100	$\pm 100\%$	50V electrolytic
C314		included in IFT302			C601 (C651)	1-107-085	100p	$\pm 5\%$	50V silvered mica
C315	1-101-073	0.02	$\pm 80\%$	25V ceramic	C602 (C652)	1-105-681-12	0.047	$\pm 10\%$	50V mylar
C316	1-121-409	47	$\pm 100\%$	16V electrolytic	C603 (C653)	1-105-685-12	0.1	$\pm 10\%$	50V mylar
C317	1-105-843-12	0.068	$\pm 20\%$	50V mylar	C604 (C654)	1-105-661-12	0.001	$\pm 10\%$	50V mylar
C318	1-105-837-12	0.022	$\pm 20\%$	50V mylar	C605 (C655)	1-121-420	220	$\pm 100\%$	10V electrolytic
C319	1-127-021	0.33	$\pm 20\%$	10V electrolytic (aluminum)	C606 (C656)	1-107-131	100p	$\pm 10\%$	50V silvered mica
C320	1-101-072	0.01	$\pm 80\%$	25V ceramic	C607 (C657)	1-121-420	220	$\pm 100\%$	10V electrolytic
C321	1-101-073	0.02	$\pm 80\%$	25V ceramic	C608 (C658)	1-121-396	4.7	$\pm 150\%$	50V electrolytic
C322	1-121-391	1	$\pm 150\%$	50V electrolytic	C609 (C659)	1-105-671-12	0.0068	$\pm 10\%$	50V mylar
C323	1-121-391	1	$\pm 150\%$	50V electrolytic	C610 (C660)	1-105-681-12	0.047	$\pm 10\%$	50V mylar
C324	1-101-073	0.02	$\pm 80\%$	25V ceramic	C611 (C661)	1-105-683-12	0.068	$\pm 10\%$	50V mylar
C325	1-105-829-12	0.0047	$\pm 20\%$	50V mylar	C612 (C662)	1-105-681-12	0.047	$\pm 10\%$	50V mylar
C326	1-121-409	47	$\pm 100\%$	16V electrolytic	C613 (C663)	1-105-669-12	0.0047	$\pm 10\%$	50V mylar
C327	1-103-617	470p	$\pm 5\%$	50V styrol	C614	1-121-405	33	$\pm 100\%$	50V electrolytic
C328	1-101-871	30p	$\pm 5\%$	50V ceramic	C701 (C751)	1-105-689-12	0.22	$\pm 10\%$	50V mylar
C329	1-101-073	0.02	$\pm 80\%$	25V ceramic	C702 (C752)	1-121-395	4.7	$\pm 150\%$	25V electrolytic
C330	1-101-073	0.02	$\pm 80\%$	25V ceramic	C703 (C753)	1-107-044	3.3p	$\pm 0.5p$	500V silvered mica
C331	1-101-073	0.02	$\pm 80\%$	25V ceramic	C704 (C754)	1-107-015	47p	$\pm 10\%$	500V silvered mica
C332	1-121-415	100	$\pm 100\%$	16V electrolytic	C705 (C755)	1-121-425	470	$\pm 100\%$	10V electrolytic
C335	1-121-391	1	$\pm 150\%$	50V electrolytic	C706 (C756)	1-121-402	33	$\pm 100\%$	10V electrolytic
C336	1-101-073	0.02	$\pm 80\%$	25V ceramic	C707 (C757)	1-121-738	10	$\pm 100\%$	50V electrolytic
C401	1-105-683-12	0.068	$\pm 10\%$	50V mylar	C708 (C758)	1-121-405	33	$\pm 100\%$	50V electrolytic
C402	1-105-661-12	0.001	$\pm 10\%$	50V mylar	C709 (C759)	1-121-405	33	$\pm 100\%$	50V electrolytic
C403	1-105-661-12	0.001	$\pm 10\%$	50V mylar	C710 (C760)	1-105-681-12	0.047	$\pm 10\%$	50V mylar
C404	1-121-398	10	$\pm 100\%$	25V electrolytic	C711 (C761)	1-105-681-12	0.047	$\pm 10\%$	50V mylar
C405	1-105-669-12	0.0047	$\pm 10\%$	50V mylar	C712 (C762)	1-105-679-12	0.033	$\pm 10\%$	50V mylar
C406	1-121-344	3.3	$\pm 150\%$	25V electrolytic	C713	1-105-757-12	0.022	$\pm 10\%$	200V mylar
C407	1-121-413	100	$\pm 100\%$	6.3V electrolytic	C714	1-107-096	300p	$\pm 5\%$	50V silvered mica
C408	1-121-409	47	$\pm 100\%$	16V electrolytic	C801	1-105-757-12	0.022	$\pm 10\%$	200V mylar
C409	1-103-575	4,700p	$\pm 5\%$	50V styrol	C802	1-105-757-12	0.022	$\pm 10\%$	200V mylar
C410	1-127-022	0.47	$\pm 20\%$	10V electrolytic (aluminum)	C803	1-105-757-12	0.022	$\pm 10\%$	200V mylar
C411	1-121-403	33	$\pm 100\%$	16V electrolytic	C804	1-105-757-12	0.022	$\pm 10\%$	200V mylar
C412	1-121-403	33	$\pm 100\%$	16V electrolytic	C805	1-105-719-12	0.033	$\pm 10\%$	100V mylar
C415	1-121-402	33	$\pm 100\%$	6.3V electrolytic	C806	1-105-719-12	0.033	$\pm 10\%$	100V mylar
C416	1-101-884	56p	$\pm 5\%$	50V ceramic	C807	1-121-736	1,000	$\pm 100\%$	10V electrolytic
C417	1-101-884	56p	$\pm 5\%$	50V ceramic	C808	1-121-736	1,000	$\pm 100\%$	10V electrolytic
C418	1-121-391	1	$\pm 150\%$	50V electrolytic	C809	1-121-559	50	$\pm 100\%$	100V electrolytic
C419	1-121-391	1	$\pm 150\%$	50V electrolytic	C810	1-121-559	50	$\pm 100\%$	100V electrolytic
C420	1-121-419	220	$\pm 100\%$	6.3V electrolytic	C811	1-121-559	50	$\pm 100\%$	100V electrolytic
C421	1-121-419	220	$\pm 100\%$	6.3V electrolytic	C812	1-121-559	50	$\pm 100\%$	100V electrolytic
C422	1-105-683-12	0.068	$\pm 10\%$	50V mylar	C813	1-121-423	220	$\pm 100\%$	50V electrolytic
C423	1-105-683-12	0.068	$\pm 10\%$	50V mylar	C814	1-121-413	100	$\pm 100\%$	6.3V electrolytic
C424	1-127-013	2.2	$\pm 20\%$	6.3V electrolytic (aluminum)	C815	1-121-417	100	$\pm 100\%$	50V electrolytic
C425	1-127-013	2.2	$\pm 20\%$	6.3V electrolytic (aluminum)	C816	1-121-423	220	$\pm 100\%$	50V electrolytic
C426	1-105-667-12	0.0033	$\pm 10\%$	50V mylar	C817	1-105-719-12	0.033	$\pm 10\%$	100V mylar
C427	1-121-409	47	$\pm 100\%$	16V electrolytic	C818	1-105-719-12	0.033	$\pm 10\%$	100V mylar
C428	1-127-021	0.33	$\pm 20\%$	10V electrolytic (aluminum)	C819	1-121-388	1,000	$\pm 100\%$	35V electrolytic
C501	1-121-405	33	$\pm 100\%$	50V electrolytic	C820	1-121-422	220	$\pm 100\%$	25V electrolytic
					C821	1-121-426	470	$\pm 100\%$	16V electrolytic
					C822	1-101-073	0.02	$\pm 80\%$	25V ceramic
					C823	1-121-426	470	$\pm 100\%$	16V electrolytic
					C824	1-121-426	470	$\pm 100\%$	16V electrolytic

<u>Ref. No.</u>	<u>Part No.</u>	<u>Description</u>	<u>Ref. No.</u>	<u>Part No.</u>	<u>Description</u>
C825	1-121-425	470 $\pm 100/10\%$ 10V electrolytic	R224	1-244-673	1k
C826	1-105-675-12	0.015 $\pm 10\%$ 50V mylar	R225	1-244-649	100
C827	1-105-679-12	0.033 $\pm 10\%$ 50V mylar	R226	1-244-679	1.8k
C828	1-105-681-12	0.047 $\pm 10\%$ 50V mylar	R227	1-244-721	100k
C901	1-101-073	0.02 $\pm 80/20\%$ 25V ceramic	R228	1-244-659	270
C902	1-105-679-12	0.033 $\pm 10\%$ 50V mylar	R229	1-244-705	22k
C903	1-105-679-12	0.033 $\pm 10\%$ 50V mylar	R230	1-244-695	8.2k
C904	1-121-330	1,000 $\pm 100/10\%$ 63V electrolytic	R231	1-244-673	1k
C905	1-121-817	6,000 $\pm 100/10\%$ 63V electrolytic	R232	1-244-721	100k
C906	1-121-817	6,000 $\pm 100/10\%$ 63V electrolytic	R233	1-244-649	100
CV101	1-151-191-13S	capacitor, tuning	R234	1-244-665	470
CV102			R235	1-244-709	33k
CV103			R236	1-244-697	10k
CV104			R237	1-244-673	1k
CV301			R238	1-244-673	1k
CV302	1-141-094	ceramic trimmer	R239	1-244-673	1k
CT104			R240	1-244-649	100

RESISTORS

All resistance values are in ohms, $\pm 5\%$, $1/4W$ and carbon type unless otherwise indicated.

R101	1-244-665	470	R247	1-244-699	12k
R102	1-244-689	4.7k	R248	1-244-745	1M
R103	1-244-697	10k	R249	1-244-734	360k
R104	1-244-666	510	R250	1-244-745	1M
R105	1-244-673	1k	R251	1-244-723	120k
R106	1-244-685	3.3k	R252	1-244-735	390k
R107	1-244-677	1.5k	R253	1-244-745	1M
R108	1-244-666	510	R254	1-244-642	51
R109	1-244-692	6.2k	R255	1-244-642	51
R110	1-244-697	10k	R256	1-244-632	20
R111	1-244-721	100k	R257	1-244-657	220
R113	1-244-642	51	R258	1-244-703	18k
R114	1-244-677	1.5k	R259	1-244-689	4.7k
R115	1-244-697	10k	R260	1-244-632	20
R201	1-244-671	820	R261	1-244-699	12k
R202	1-244-677	1.5k	R262	1-244-642	51
R203	1-244-685	3.3k	R263	1-244-680	2k
R204	1-244-653	150	R264	1-244-699	12k
R205	1-244-673	1k	R265	1-244-720	91k
R206	1-244-673	1k	R266	1-244-701	15k
R207	1-244-671	820	R267	1-244-733	330k
R208	1-244-677	1.5k	R268	1-244-701	15k
R209	1-244-685	3.3k	R270	1-244-659	270
R210	1-244-653	150	R271	1-244-705	22k
R211	1-244-673	1k	R272	1-244-658	240
R212	1-244-673	1k	R301	1-244-699	12k
R213	1-244-649	100	R302	1-244-705	22k
R214	1-244-657	220	R303	1-244-685	3.3k
R215	1-244-721	100k	R304	1-244-673	1k
R216	1-244-671	820	R305	1-244-663	390
R217	1-244-689	4.7k	R306	1-244-697	10k
R218	1-244-675	1.2k	R307	1-244-689	4.7k
R219	1-244-653	150	R308	1-244-673	1k
R220	1-244-663	390	R309	1-244-677	1.5k
R221	1-244-677	1.5k	R310	1-244-707	27k
R222	1-244-679	1.8k	R311	1-244-691	5.6k
R223	1-244-671	820	R312	1-244-673	1k

**SCHEMATIC DIAGRAM
TUNER SECTION**

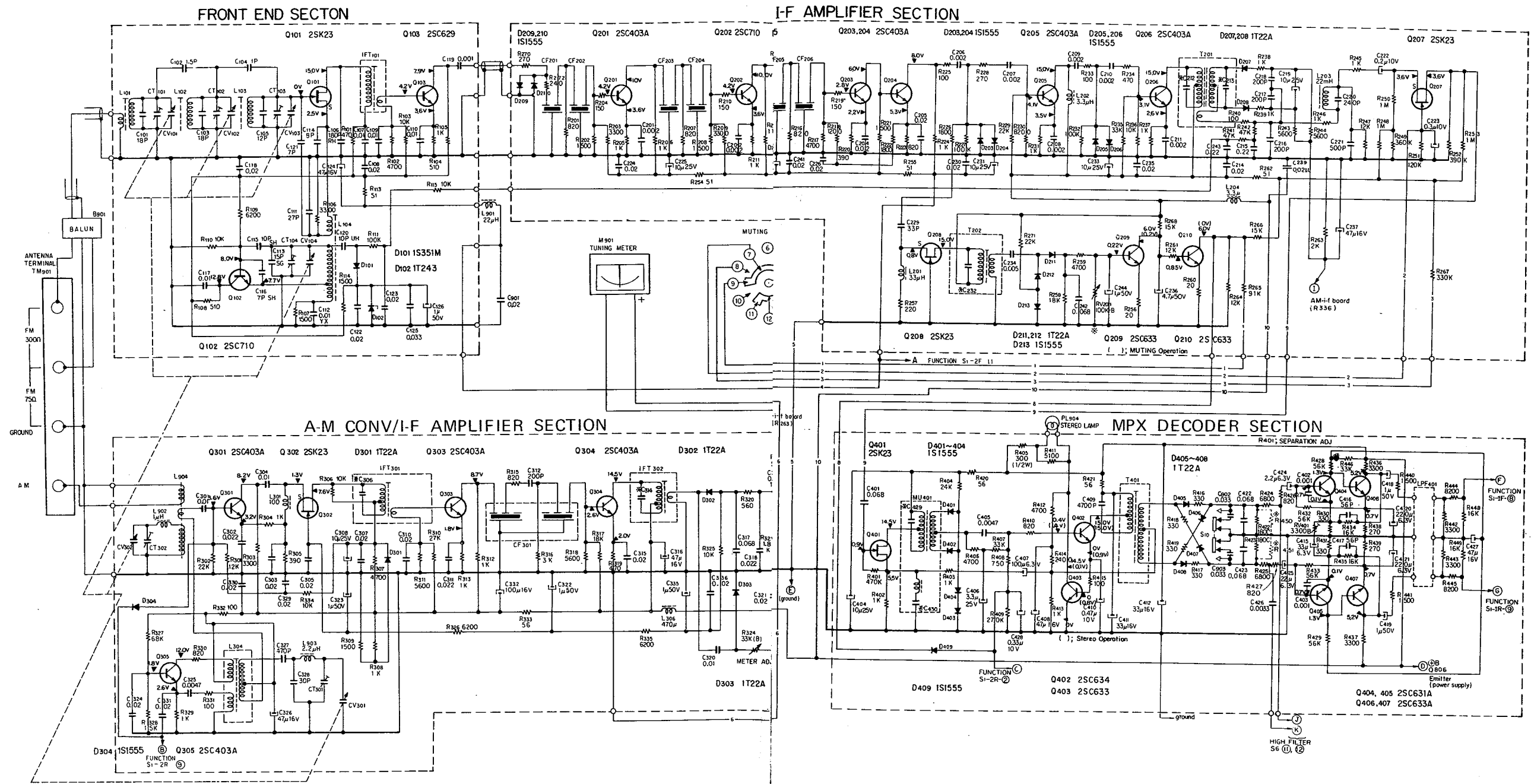

Ref. No.	Description	Position
S9	MUTING SW	ON
S10	DE-EMPHASIS SW	75 μsec

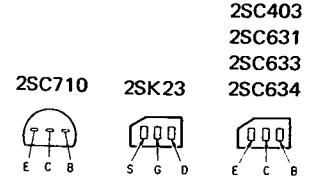
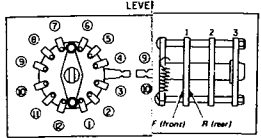

Note:
All resistance values are in ohms. k = 1,000, M = 1,000k
All capacitance values are in μF except as indicated with p, which means pF.
All voltages represent an average value and should hold within ±20%.
All voltages are dc measured with a VOM which has an input impedance of 20k ohms/volt. No signal in.

SCHEMATIC DIAGRAM

AUDIO SECTION

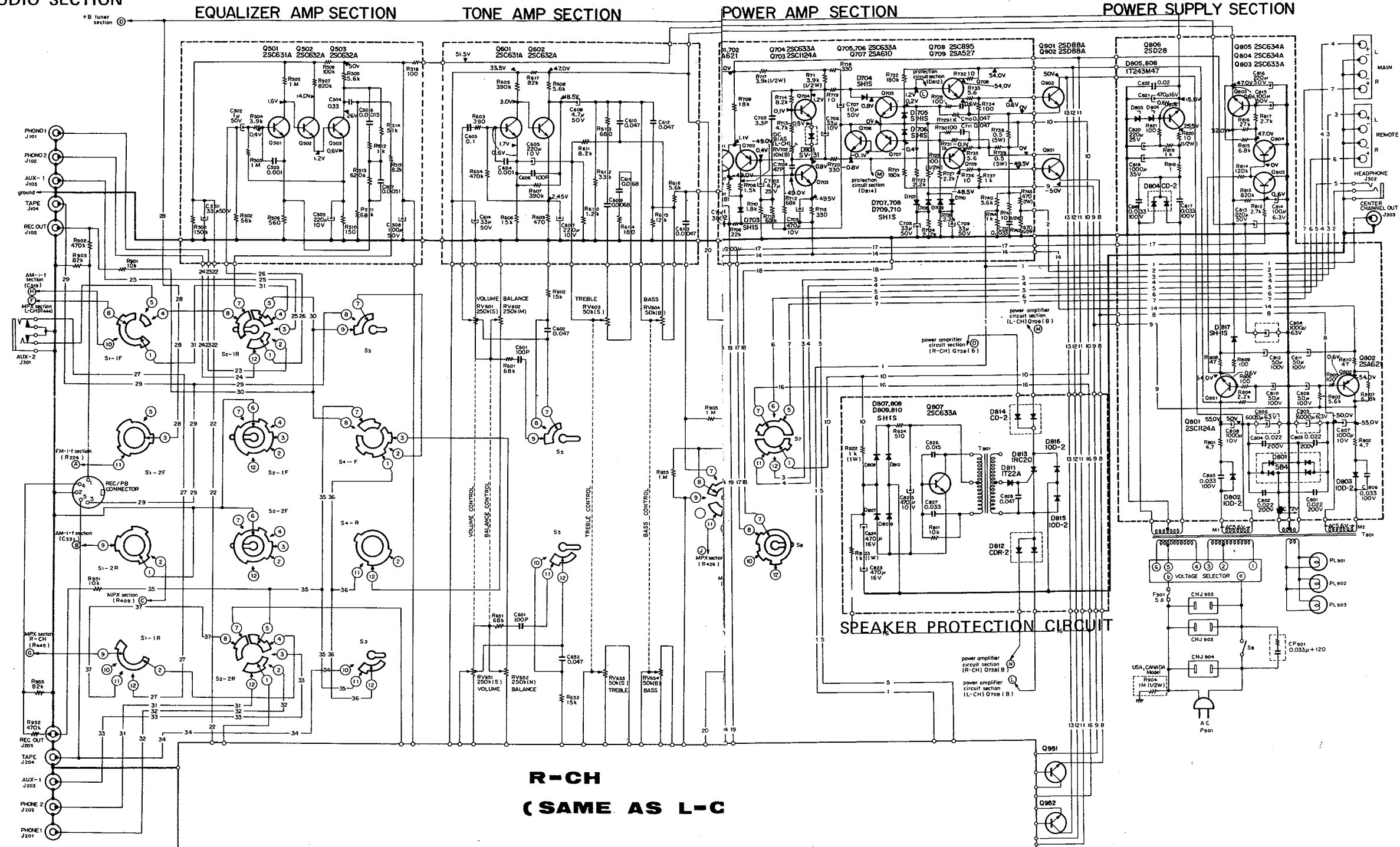

Ref. No.	Description	Position
S1	FUNCTION (1) (FM AUTO STEREO - FM MONO - AM - PHONO-2 - AUX-2)	AUTO STEREO
S2	FUNCTION (2) SW (AUX-1 - FUNCTION (1) - PHONO-1)	FUNCTION (1)
S3	MONITOR SW (SOURCE - TAPE)	SOURCE
S4	MODE SW (REVERSE - STEREO - L+R - LEFT - RIGHT)	STEREO

Ref. No.	Description	Position
S5	LOUDNESS SW	ON
S6	HIGH FILTER	OFF
S7	SPEAKER SW (REMOTE - OFF - MAIN - BOTH)	BOTH
S8	POWER SW	OFF

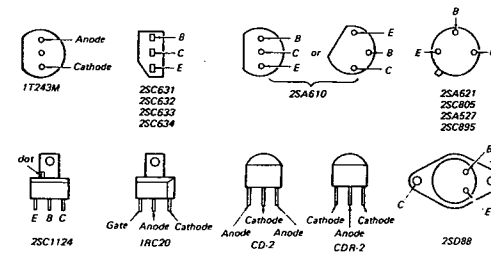
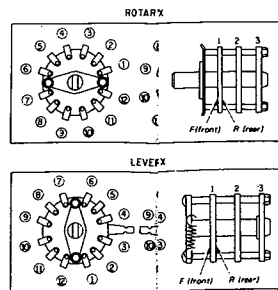

Note:
 All resistance values are in ohms. k=1,000, M=1,000k
 All capacitance values are in μ F except as indicated with p, which means μ F.
 All voltages represent an average value and should hold within $\pm 20\%$.
 All voltages are dc measured with a VOM which has an input impedance of 20k ohms/volt. No signal in.

SONY
STR-6065

<u>Ref. No.</u>	<u>Part No.</u>	<u>Description</u>	<u>Ref. No.</u>	<u>Part No.</u>	<u>Description</u>
R313	1-244-673	1k	R439	1-244-659	270
R315	1-244-671	820	R440	1-244-677	1.5k
R316	1-244-684	3k	R441	1-244-677	1.5k
R317	1-244-703	18k	R442	1-244-685	3.3k
R318	1-244-691	5.6k	R443	1-244-685	3.3k
R319	1-244-665	470	R444	1-244-695	8.2k
R320	1-244-667	560	R445	1-244-695	8.2k
R321	1-244-679	1.8k	R446	1-244-709	33k
R322	1-244-694	7.5k	R448	1-244-702	16k
R323	1-244-673	1k	R449	1-244-702	16k
R324	1-222-984	33k (B), semi-fixed	R501	1-242-725	150k
R325	1-244-697	10k	R502 (R552)	1-242-715	56k
R326	1-244-692	6.2k	R503 (R553)	1-242-745	1M
R327	1-244-717	68k	R504 (R554)	1-242-687	3.9k
R328	1-244-701	15k	R505 (R555)	1-242-745	1M
R329	1-244-673	1k	R506 (R556)	1-242-667	560
R330	1-244-671	820	R507 (R557)	1-242-743	820k
R331	1-244-649	100	R508	1-242-721	100k
R332	1-244-649	100	R509 (R559)	1-242-691	5.6k
R333	1-244-643	56	R510 (R560)	1-242-653	150
R334	1-244-697	10k	R511 (R561)	1-242-717	68k
R335	1-244-692	6.2k	R512 (R562)	1-242-673	1k
R336	1-244-673	1k	R513 (R563)	1-242-740	620k
R401	1-244-737	470k	R514 (R564)	1-242-714	51k
R402	1-244-673	1k	R515 (R565)	1-242-695	8.2k
R403	1-244-673	1k	R516	1-242-649	100
R404	1-244-706	24k	R601 (R651)	1-242-717	68k
R405	1-202-560	300	R602 (R652)	1-242-701	15k
R406	1-244-689	4.7k	R603 (R653)	1-242-663	390
R407	1-244-709	33k	R604 (R654)	1-242-737	470k
R408	1-244-670	750	R605 (R655)	1-242-735	390k
R409	1-244-731	270k	R606 (R656)	1-242-701	15k
R410	1-244-671	820	R607 (R657)	1-242-735	390k
R411	1-244-690	5.1k	R608 (R658)	1-242-691	5.6k
R412	1-244-689	4.7k	R609 (R659)	1-242-665	470
R413	1-244-673	1k	R610 (R660)	1-242-675	1.2k
R414	1-244-682	2.4k	R611 (R661)	1-242-695	8.2k
R415	1-244-649	100	R612 (R662)	1-242-709	33k
R416	1-244-661	330	R613 (R663)	1-242-669	680
R417	1-244-661	330	R614 (R664)	1-242-655	180
R418	1-244-661	330	R615 (R665)	1-242-699	12k
R419	1-244-661	330	R616 (R666)	1-242-691	5.6k
R420	1-244-643	56	R617	1-242-719	82k
R421	1-244-643	56	R702 (R752)	1-242-705	22k
R422	1-244-679	1.8k	R703 (R753)	1-242-717	68k
R423	1-244-679	1.8k	R704	1-242-705	22k
R424	1-244-693	6.8k	R705 (R755)	1-242-677	1.5k
R425	1-244-693	6.8k	R706	1-242-705	22k
R426	1-244-671	820	R707 (R757)	1-242-677	1.5k
R427	1-244-671	820	R708 (R758)	1-242-677	1.5k
R428	1-244-715	56k	R709 (R759)	1-242-703	18k
R429	1-244-715	56k	R710 (R760)	1-242-679	1.8k
R430	1-244-661	330	R711 (R761)	1-242-717	68k
R431	1-244-661	330	R712 (R762)	1-242-717	68k
R432	1-244-715	56k	R713 (R763)	1-242-689	4.7k
R433	1-244-715	56k	R714 (R764)	1-242-695	8.2k
R434	1-244-702	16k	R715 (R765)	1-242-661	330
R435	1-244-702	16k	R716 (R766)	1-202-587	3.9k
R436	1-244-685	3.3k	R717 (R767)	1-202-587	3.9k
R437	1-244-685	3.3k			
R438	1-244-659	270			

±10% ½W composition

±5% ½W composition

±5% ½W composition

Ref. No.	Part No.	Description
R718 (R768)	1-242-661	330
R719 (R769)	1-242-625	10
R720 (R770)	1-242-661	330
R721 (R771)	1-242-727	180k
R722 (R772)	1-242-727	180k
R723 (R773)	1-242-681	2.2k
R724 (R774)	1-242-681	2.2k
R725 (R775)	1-202-549	100 ±5% ½W composition
R726 (R776)	1-242-681	2.2k
R727 (R777)	1-242-681	2.2k
R728 (R778)	1-242-649	100
R729 (R779)	1-242-673	1k
R730 (R780)	1-242-649	100
R731 (R781)	1-242-673	1k
R732 (R782)	1-242-625	10
R733 (R783)	1-242-619	5.6
R734 (R784)	1-242-649	100
R735 (R785)	1-242-619	5.6
R736 (R786)	1-242-625	10
R737 (R787)	1-242-673	1k
R738 (R788)	1-205-803	0.5 ±10% 5W wire wound
R739 (R789)	1-205-803	0.5 ±10% 5W wire wound
R740 (R790)	1-242-691	5.6k
R741 (R791)	1-202-525	10 ±5% ½W composition
R742 (R792)	1-202-565	470 ±5% ½W composition
R743 (R793)	1-206-089	470 ±10% 1W metal-oxide
R744	1-242-673	1k
R801	1-244-617	4.7
R802	1-244-617	4.7
R803	1-244-691	5.6k
R804	1-244-681	2.2k
R805	1-244-649	100
R806	1-244-649	100
R807	1-244-693	6.8k
R808	1-244-641	47
R809	1-244-649	100
R810	1-244-641	47
R811	1-244-697	10k
R812	1-244-683	2.7k
R813	1-244-743	820k
R814	1-244-723	120k
R815	1-244-693	6.8k
R816	1-244-707	27k
R817	1-244-683	2.7k
R818	1-244-601	1
R818	1-244-673	1k
R819	1-202-525	10 ±10% ½W composition
R820	1-244-649	100
R821	1-244-693	1k ±10% 1W metal-oxide
R822	1-206-093	1k ±10% 1W metal-oxide
R823	1-206-093	1k ±10%
R824	1-244-666	510
R901 (R951)	1-244-697	10k
R902 (R952)	1-244-737	470k
R903 (R953)	1-244-719	82k
R904	1-202-645	1M ±10% ½W composition (USA, CANADA Model only)
R905 (R955)	1-242-745	1M
RV201	1-221-966	100k (B), semi-fixed
RV401	1-222-948	3.3k (B), semi-fixed

Ref. No.	Part No.	Description
RV601	1-222-392	250k variable (volume control)
(RV651)		
RV602	1-222-392	250k variable (balance control)
(RV652)		
RV603	1-222-373	50k variable (tone control, treble)
(RV653)		
RV604	1-222-374	50k variable (tone control, bass)
(RV654)		
RV701	1-221-967	10k (B), semi-fixed
(RV751)		
RV702	1-221-967	10k (B), semi-fixed
(RV752)		

SWITCHES

S1	1-514-770	switch, rotary (FUNCTION 1)
S2	1-514-681	switch, lever (FUNCTION 2)
S3	1-513-338	switch, lever (MONITOR)
S4	1-514-508	switch, rotary (MODE)
S5	1-513-338	switch, lever (LOUDNESS)
S6	1-514-511	switch, lever (HIGH FILTER)
S7	1-514-507	switch, rotary (SPEAKER)
	1-514-369-12S	switch, lever (POWER) (CANADA General Export Model)
S8	1-514-369-22S	switch, lever (POWER) (USA Model)
S9	1-513-338	switch, lever (MUTING)
S10	1-514-524	switch, slide (DE-EMPHASIS)

FILTERS

			(Color)	(Specified Center Freq.)
CF201	1-403-562-11	fm i-f, ceramic	red	10.70 MHz
CF202	1-403-562-21	fm i-f, ceramic	black	10.66 MHz
CF203	1-403-562-31	fm i-f, ceramic	white	10.74 MHz
CF204				
CF205	1-403-562-41	fm i-f, ceramic	green	10.62 MHz
CF206	1-403-562-51	fm i-f, ceramic	yellow	10.78 MHz
CF301	1-403-153	filter, ceramic		455 kHz
LPF401	1-231-088	filter, low-pass		

MISCELLANEOUS

1-231-057	encapsulated component, 120Ω ± 0.033μF
1-507-163	phono jack, 4-P
1-507-176	phono jack, 1-P
1-507-185	phono jack, 6-P
1-507-190	jack, HEADPHONE; AUX-2
1-509-029	REC/PB connector
1-509-341	AC outlet
1-517-021	socket, meter lamp
1-518-017-02	lamp, meter 8V/0.15A
1-518-051-22	lamp, stereo 4.5V/40mA
1-518-070	lamp, dial 8V/300mA
1-520-097	meter, tuning
1-526-502	socket, transistor
1-526-165	voltage changeover block
1-532-214	fuse 5A
1-533-051	socket, dial lamp
1-534-487-22	cord, power (General Export Model)
1-534-526-21	cord, power (USA, CANADA Model)
1-536-146	terminal strip, 1L1 (A)
1-536-179	terminal strip, 1L1 (C)
1-536-187	terminal strip, 1L1 (B)
1-536-284	terminal strip, 4-P

SONY CORPORATION