

AM/FM Stereo Receiver

with Quatravox[®]

STA-77A

**OWNER'S
MANUAL**

PLEASE READ BEFORE
USING THIS EQUIPMENT



REALISTIC[®]

**Cat. No.
31-2074**

CUSTOM MANUFACTURED FOR RADIO SHACK  A DIVISION OF TANDY CORPORATION

REALISTIC®

THE BRAND WITH OVER 1,000,000 CUSTOMERS

In choosing this fine Realistic product you have demonstrated a rather acute awareness of the good old American custom called "getting the most for your money". With Realistic this is not an idle boast.

The "line" was born in Boston, long famous for Yankee ingenuity — and thrift. Its original intent was to bridge a gap between \$100 equipment and \$25 equipment where, at the time, there was a real void in hi-fi merchandise.

Early products were a \$39.95 FM tuner, a \$29.95 preamp/amplifier, a \$19.95 speaker. Soon we found ourselves a unique niche as manufacturing retailers.

Capacity and ability grew simultaneously. Our Realistic Electrostat-3® electrostatic tweeter was called a "best buy" by the country's leading product-review magazine. Our 10TRF radio out-performed practically anything then available. And dealers from all over the world began requesting a Realistic franchise.

Recent "firsts" include: the first medium cost DC/AC communications receiver totally engineered in solid state — the Realistic DX-150A; the first properly designed low-cost police band radio — the Realistic Patrolman; the Realistic Optimus-1 loudspeaker, bringing "over \$120 sound" down 33%; the first lifetime-guaranteed vacuum tube; and the Realistic STA-120B stereo receiver which combined massive power, modern styling, and a veritable host of new ideas — at a cost fully \$100-\$200 below its value under traditional marketing practices.

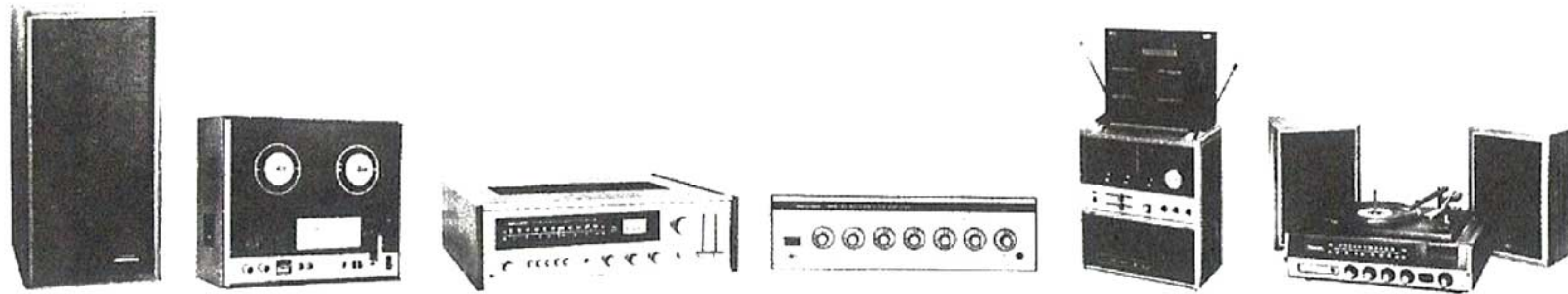

Speakers Recorders Components P.A. Products Radios Phonographs

REALISTIC AUDIO PRODUCTS are the proud result of Radio Shack engineering, research, development, and over 50 years of experience in electronics. Laboratories are maintained in Boston, Ft. Worth, Los Angeles, and abroad. In every sense a national brand, the Realistic label is worn with equal distinction by our highly original Communications and Citizens Band (two-way radio) products, and numerous other items including: tape, headphones, antennas, intercoms, and tubes.

General Description

Your STA-77A represents one of the best values available today in a high-quality receiver. Its power and versatility make it an outstanding buy.

- 18 watts of clean "honest" power will drive almost any speaker system — even **two** sets of speakers!
- The FM front-end section utilizes a "Field Effect Transistor". This means that your tuner has extra-high sensitivity combined with exceptionally low noise, an unusual immunity to distortion caused by electrical interference at these high frequencies and minute signal levels. Maybe that's a little too "technical" for you — but it's all solid up-to-the-minute engineering technology.
- The FM multiplex section employs a newly developed Phase Lock Loop IC (or P.L.L. IC) which assures stable stereo separation even if internal temperatures rise or drop.
- The dial pointer is lighted — and changes color when you tune to a stereo FM station.
- Built-in overload protection circuitry automatically shuts off the amplifier under excessive load conditions.
- Built-in Quatravox® simulates 4-channel effects from stereo sources — and it only requires a second set of stereo speakers.
- Muting eliminates interstation hiss on FM.
- A wideband tuner gives hi-fi sound even on AM.
- A factory-mounted genuine walnut veneer case, and you don't pay a penny extra.

NOTE: Before connecting the STA-77A, please read the following instructions. They will insure your getting the most enjoyment from your new receiver.

RADIO SHACK LIMITED WARRANTY

This equipment is warranted against defects for 2 years from date of purchase. Within this period, we will repair it without charge for parts and labor. Simply **bring your sales slip** as proof of purchase date to any Radio Shack store. Warranty does not cover transportation costs. Nor does it cover equipment subjected to misuse or accidental damage.

This Warranty gives you specific legal rights and you may also have other rights which vary from state to state.

We Service What We Sell

Specifications

Preamplifier-Amplifier

Audio Output Power at no more than 0.8% Total Harmonic Distortion into 8 ohms, over the audio spectrum, 20 to 20,000 Hz	: 18 watts (Minimum RMS power, both channels driven).
Frequency Response (1 watt)	15–25,000 Hz
Sensitivity (for full output)	PHONO: 2.2 mV AUX 1, 2/Tape In: 120 mV
Tape Output Level	250 mV (10 mV for DIN output)
Harmonic Distortion (at 5 watts)	0.1%
Signal-to-Noise Ratio	Aux & Tape: 70 dB Phono: 60 dB
Tone Control Action	Bass: ±10 dB @ 100 Hz Treble: ±10 dB @ 10,000 Hz

FM Tuner

Sensitivity (IHF)	1.9 μ V
Limiting Sensitivity (–3 dB)	1.8 μ V
Signal-to-Noise Ratio (1 mV)	65 dB
Total Harmonic Distortion	Mono: 0.5% Stereo: 0.6%
Stereo Separation (1 kHz)	35 dB
Image Rejection	50 dB
IF Rejection	80 dB
A.C.A.	55 dB
Capture Ratio	2 dB

AM Tuner

Terminal Sensitivity	10 μ V for 20 dB S/N
Radiated Sensitivity	200 μ V/M
Image Rejection	40 dB
Signal-to-Noise Ratio	45 dB
Total Harmonic Distortion (5 mV/M)	1%
A.G.C. Figure-of-Merit	50 dB
A.C.A.	32 dB

Antennas

AM: Built-in ferrite
FM: Linecord,
Plus terminals for external antennas.

Power Requirements

120 volt AC, 60 Hz (200 watts max.)
(220/240 V AC, 50 Hz for Australian and European models as indicated on rear of unit.)

A Typical System: STA-77A, Turntable, 4 Speakers, Tape Decks and extra Tuner

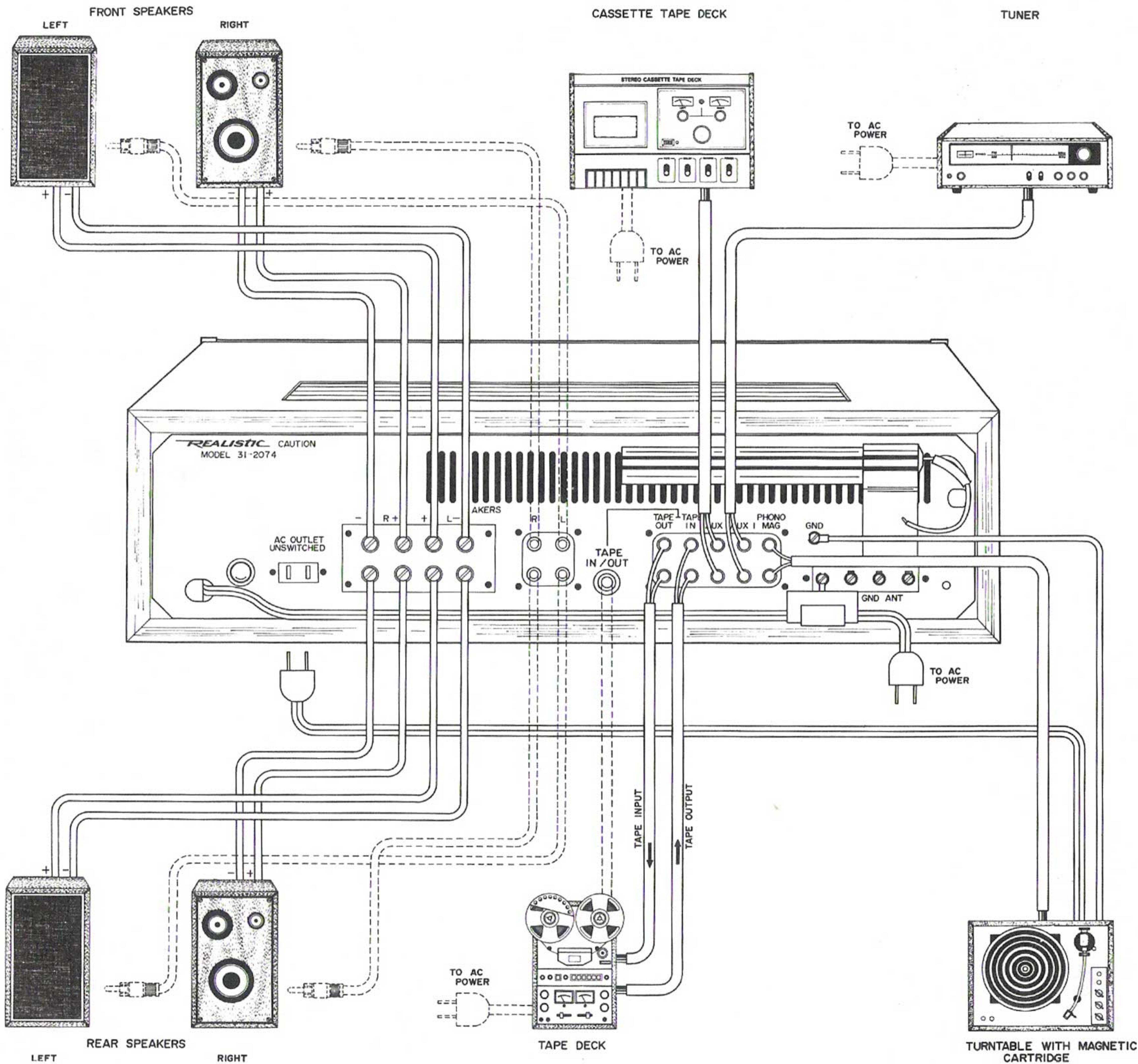

ANTENNA CONNECTIONS

BUILT-IN FM LINECORD ANTENNA

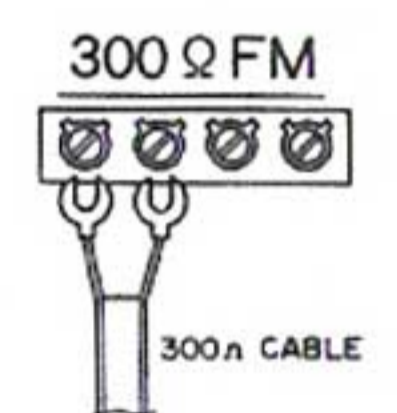
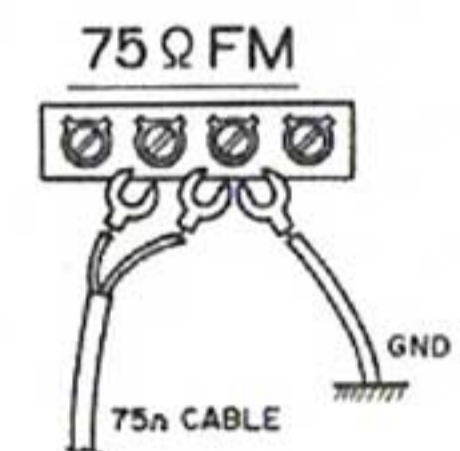
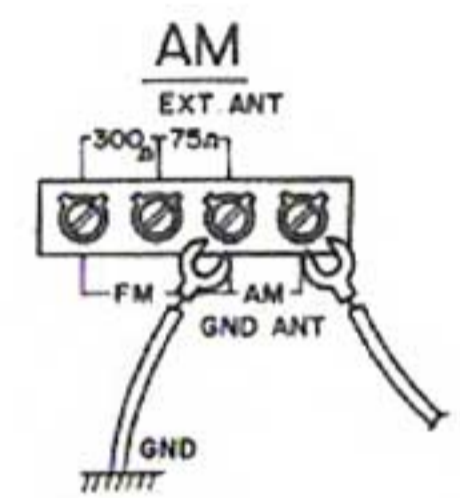
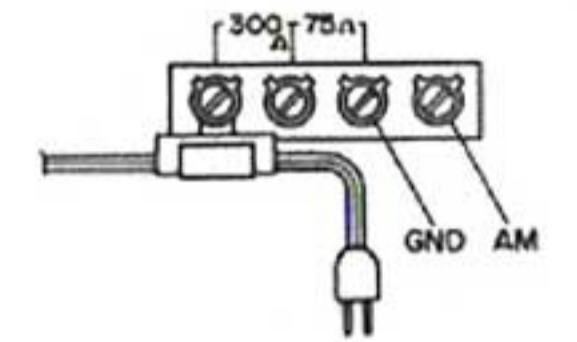

Connecting the STA-77A

SPEAKERS

No stereo system sounds better than its speakers. So we recommend you buy the best speakers you can afford, especially for the main (or front) speakers. The Realistic **Minimus**® series should represent a basic level while the **Optimus**® or **Nova**® series would be preferable. The remote (or rear) speakers can be the same or less expensive, although the Realistic **Solo**™ series should be a minimum.

The STA-77A's built-in Quatravox lets you hear sounds from your stereo records that you've never heard before. By just adding a second set of stereo speakers this circuit simulates 4-channel sound.

Most stereo recordings contain ambient (reflected) sound which an ordinary stereo system loses. Quatravox plays these sounds through the rear speakers and actually recreates the acoustics of the studio or concert hall. The degree of 4-channel effect varies with the type of music you listen to and the way it was recorded.

If your speakers have RCA phono jack connectors, hook them up to the RCA jacks on the receiver's rear panel. If your speakers have only screw terminals, use two-conductor lamp or speaker wire to connect them to the screw terminals on the STA-77A. Connect the main/front speakers to the strip marked "A/FRONT" and the remote/rear speakers to strip "B/REAR".

NOTE: When using the screw terminals be sure to observe proper polarity. Most speaker wire is clearly marked with a raised line along one conductor, or has one wire a different color from the other. Connect the (+) receiver output to the (+) or "marked" (color dot or other marking) speaker terminal, and the (-) output to the (-) or unmarked speaker terminal. **Do not allow stray strands of wire to touch adjacent terminals or the metal chassis.**

NOTE: **Use no more than four speakers with the STA-77A.** You must choose between remote speakers and Quatravox (since you can not use both remote speakers and rear Quatravox at the same time).

The STA-77A's outputs are designed for 4–16 ohm speakers. However, when more than one pair of speakers is being connected, use only 8–16 ohm systems; connect them to either screw terminals or RCA jacks — **but not both.** This will keep the amplifier circuitry from being overloaded. See also **Overload Protection** on Page 6.

PHONOGRAPH

For convenience most people prefer a record changer (Often called an automatic turntable) to a manual turntable. Realistic, Miracord, Dual, BSR and Garrard all make good automatic turntables. Be sure your turntable has a magnetic cartridge with an output of at least 2.2 mV.

Connect your turntable shielded cables to the PHONO MAG receiver inputs. You may plug the turntable's line-cord into the AC OUTLET (UNSWITCHED) or into a wall socket.

To minimize hum, connect the turntable's green or black ground wire to the GND (ground) screw on the rear panel.

TAPE DECK

Until recently, reel-to-reel tape machines were the only choice for people seriously interested in hi-fi. But recently vast improvements have been made with cassettes; for example, the widespread use of Dolby noise reduction and the introduction of high-performance tapes. The best cassette decks now rival reel-to-reel machines.

Eight-track recorders have only slightly less fidelity than cassettes or reel-to-reel, but have several advantages. You can play car tape cartridges at home and save money by recording your own tapes. In addition 8-track cartridges are continuous loops, will play for hours and require no attention.

Using shielded cable connect the STA-77A's TAPE OUT jacks to the tape recorder's input, usually labeled AUX/LINE IN. Connect the tape deck output to the Receiver's TAPE IN jacks. Plug the deck's line cord into the AC OUTLET (UNSWITCHED) or into a wall socket.

A second tape player (8-track, cassette or reel-to-reel) can be connected to one of the pairs of AUX Input jacks. Thus, you can play tapes when using the AUX position of the Function switch.

Any other high-level sound source can be connected to the AUX Input jacks — another tuner, a record player with ceramic or crystal cartridge, TV sound, etc.

If your tape recorder has a DIN-type socket, use a cable with DIN-type connectors and plug into the DIN-type socket on the Receiver.

FM and AM ANTENNAS

The built-in antennas are adequate for most areas, for other antenna provisions see the illustration on the facing page, also page 7.

Front Panel

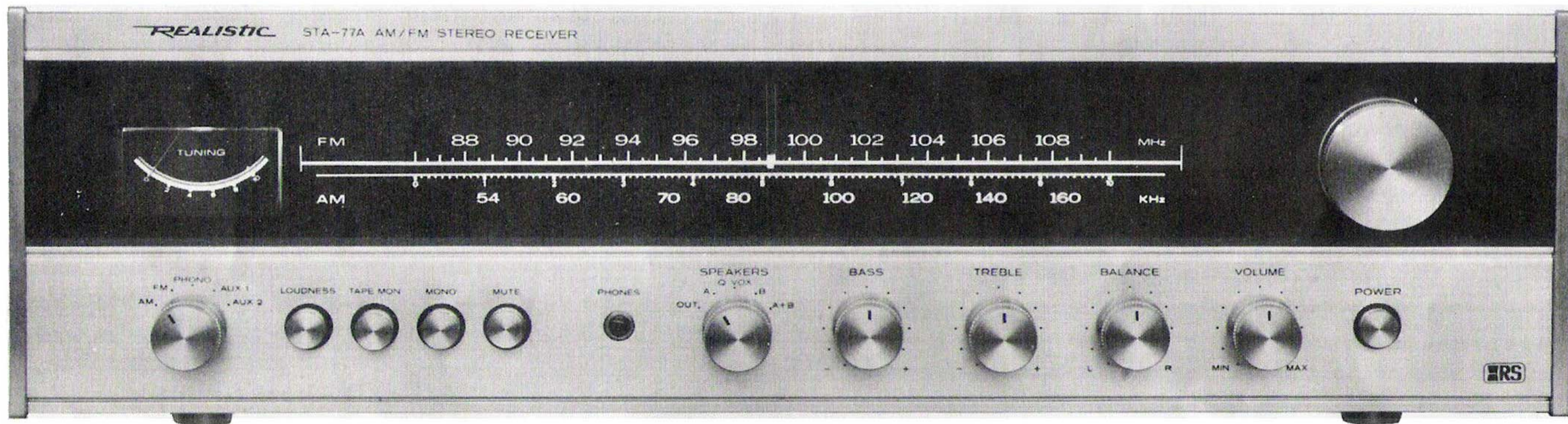

Before plugging the receiver in —

- Check the POWER switch, put it in its "out" position.
- Put all other pushbutton switches in the "out" position.
- Turn the VOLUME fully counterclockwise.
- Make connections shown on page 2.

OPERATING INSTRUCTIONS

Press the POWER switch to turn the unit on. Select one of the inputs by turning the Function switch (at the extreme left) to the desired source.

Set the SPEAKERS switch to the desired position. "A" selects the main/front speakers only; "B" selects only the remote/rear speakers. "A+B" plays the same program through both sets of speakers. "Q-VOX" feeds slightly different signals to the "B" speakers which then function as the rear sound for simulated 4-channel sound. The "Out" position permits you to turn off all the speakers for head-phone listening.

Adjust VOLUME to the desired level. Turn the BALANCE control until you feel a slight catch near the 12 o'clock position. At this position the two speakers play with equal volume. The balance control can compensate to some extent for off-center listening positions, variations in listening room conditions or defects in the original recording.

The four pushbutton switches at the left should be "out" for normal listening. For mono operation press in the MONO button.

At their center settings the BASS and TREBLE controls do not affect the tone and you will hear "flat" (unaltered) sound. To increase the bass or treble turn the desired control clockwise; to decrease, turn the controls counterclockwise. In this decreased position the tone controls can reduce hiss (high pitched noise) or rumble (low frequency noise). The LOUDNESS button boosts low and high frequencies at its in position. This compensates for the ear's lack of sensitivity to extreme bass and treble at low volumes.

FM

Turn the Function switch to FM and adjust the Tuning knob for the desired station. Fine-tune for maximum reading on the TUNING meter.

The dial pointer will change from yellow to red when you tune in a station broadcasting in stereo. Any time the pointer is red, you know you are listening to a stereo FM station. For AM or monaural FM signals (or if you press MONO switch in), the dial pointer will be yellow.

The MUTE switch, when pressed in, removes interstation hiss and noise. When tuning weak stations you may need to turn the muting off to get a signal. Noise on weak stations will be greatly reduced when you press the MONO button in.

With the MONO button in its normal (out) position, the tuner will automatically switch from mono to stereo when tuned to a stereo FM station.

AM

Turn the Function switch to AM and adjust the Tuning knob for maximum reading on the TUNING meter. Position the ferrite core antenna (rear panel) for the best reception.

PHONOGRAPH

Turn the Function switch to PHONO and adjust the VOLUME and Tone controls.

For the best sound and longest record life do not track your cartridge below the recommended force. Light tracking may actually cause more distortion than heavy tracking.

TAPE

Playback

Press the TAPE MONitor button and adjust the VOLUME and Tone controls. (TAPE MON overrides any position of the Function switch.)

NOTE: If you leave TAPE MON pressed in, you will not be able to hear the receiver's FM, AM, AUX 1, AUX 2 or PHONO function.

Record

Set the Function switch to the desired input and adjust the Receiver's controls for your own enjoyment (VOLUME, BALANCE and Tone controls do not affect the output to the tape recorder).

When using a three-head tape deck you can listen to the tape while still recording. Just press the TAPE MONitor button in.

For the best operation of your tape recorder clean the heads frequently with isopropyl alcohol and a cotton swab. For lowest distortion and tape noise use one of the tape head demagnetizers available at your Radio Shack store.

OPERATING INSTRUCTIONS (cont.)

AUX 1 AND 2 INPUTS

Turn the Function switch to the desired input and adjust VOLUME, BALANCE and Tone controls. The auxiliary inputs can be used for any high-level source such as a tape player, a second tuner, TV, ceramic or crystal phono cartridge, ham radio, etc.

HEADPHONE JACK

The PHONES jack is "live" at all times. To listen only to the headphones turn SPEAKERS switch to "OUT".

OVERLOAD PROTECTION

Your Receiver has built-in, automatic overload protection. If an abnormal load is presented to the speaker terminals, this protective circuit will automatically silence the Receiver. If this happens, turn POWER "off" and check all speaker connections; be sure no pieces of wire are touching between speaker terminals and be sure you don't have 4 ohm speakers connected for **both** MAIN and REMOTE.

When you are sure everything is OK, apply power once more.

FUSE

If the fuse blows, do not replace with higher rating fuse. Use only a 3A rated fuse.

HINTS FOR BETTER SOUND

Quatravox Speaker Placement

Where you put the speakers is more critical with 4-channel than it is with stereo. So before you settle on one position try several others — either those illustrated or ones dictated by your listening room.

The theoretically ideal position, one speaker in each corner of a room with the listening position in the center, is shown in Figure A. Since this arrangement is inconvenient in many home installations you may want to modify it. Figure B represents the situation in many homes. The listener faces the two front speakers while the rear speakers face each other.

Figures C and D produce a different type of sensation. Instead of being surrounded by sound, the two rear speakers create a sense of depth — as if you were sitting in the audience at a live performance. Depending on the size of your room and the dispersion of your rear speakers you may want them to face you or to face each other.

There are almost an infinite number of satisfying speaker locations for Quatravox, so if one of these doesn't suit your needs invent your own.

Speaker Arrangements for Quatravox

● = listener's position ↑ = direction of sound

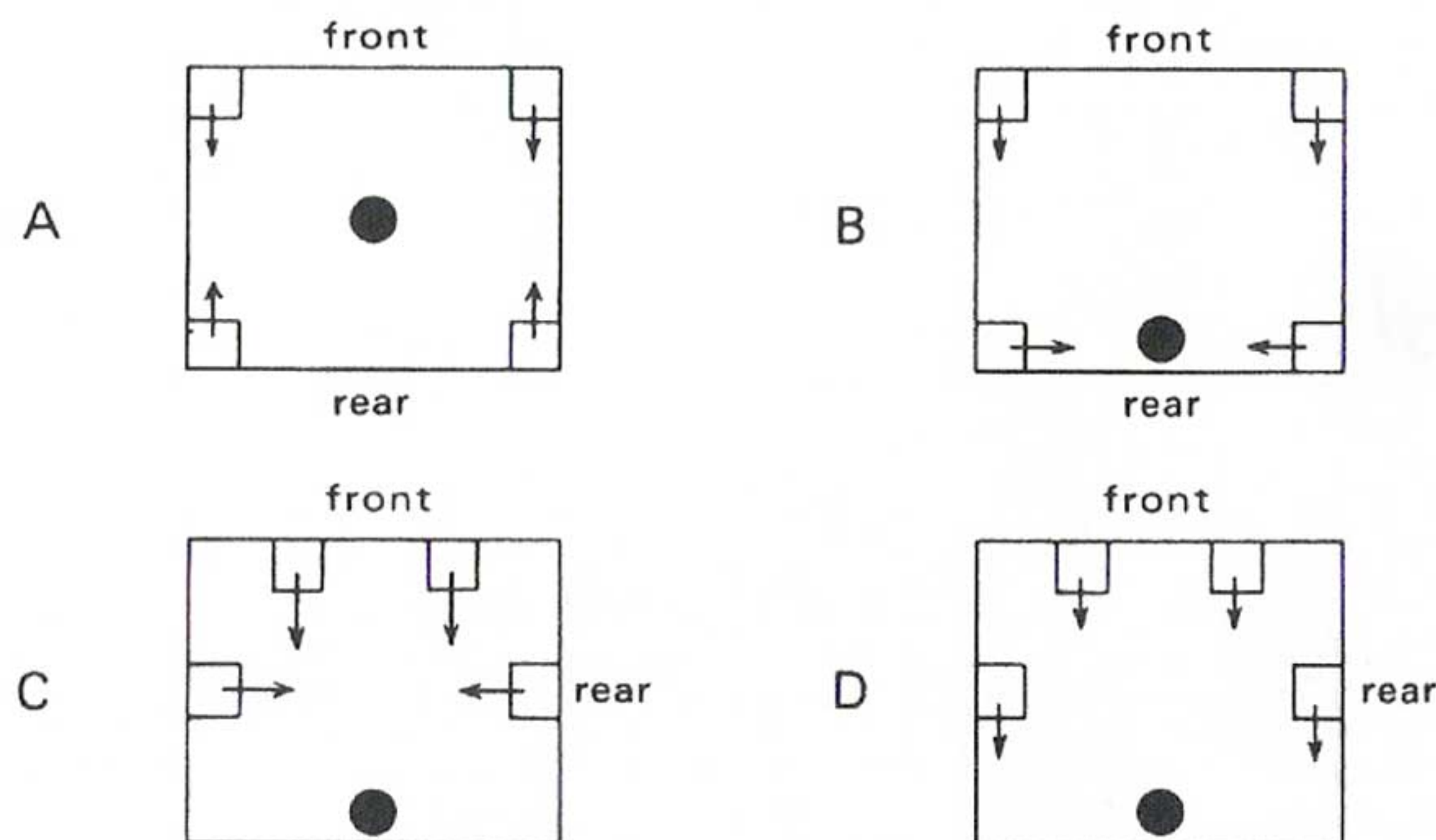

All arrangements based on 6-8' (1.8-2.4 m) minimum front speaker separation.

Antennas

Under most conditions your STA-77A's built-in antennas should be adequate for AM and FM reception. If you cannot get adequate reception, try one of the arrangements listed below. Your Radio Shack salesman knows about reception difficulties in your area.

For FM, build the very low-cost folded-dipole (illustrated); or buy one ready-made from Radio Shack (42-2385). Just splice regular 300 ohm lead-in wire as shown. Apply a small amount of solder and heat the twisted ends until it flows evenly over each strand of wire. This antenna can be tacked to the back of a record cabinet or onto a wall – the higher the better.

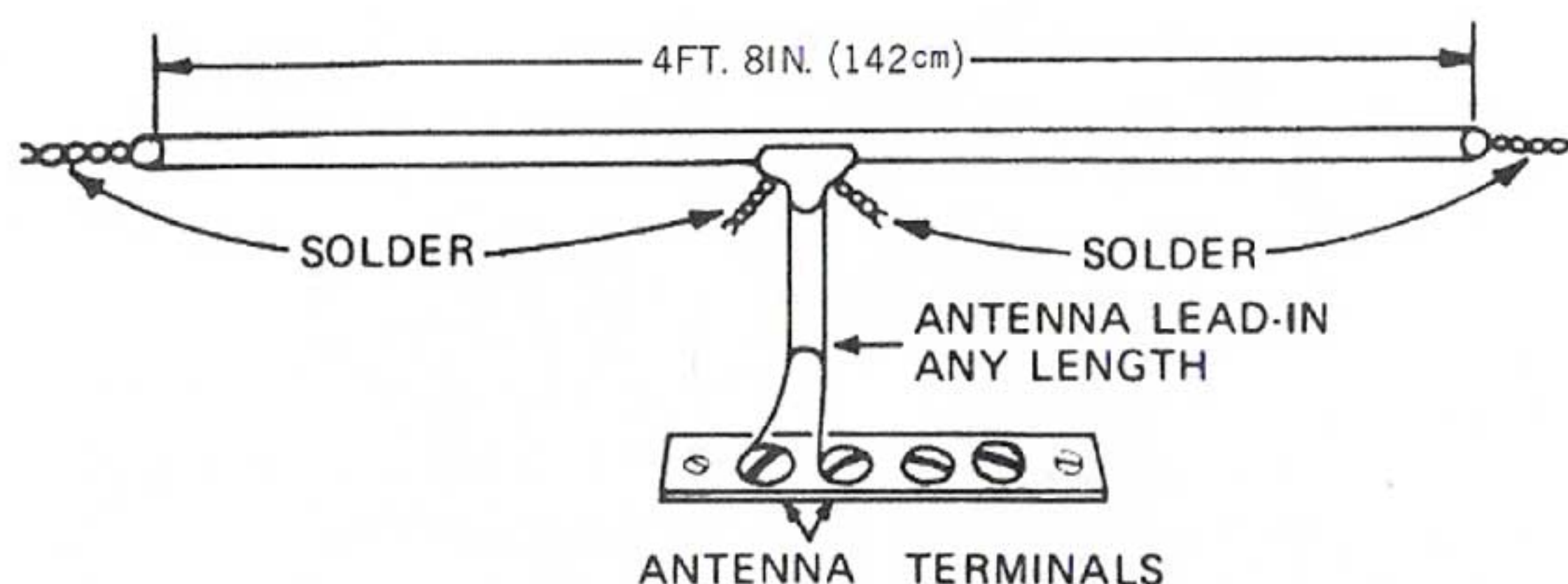

A set of VHF rabbit ears or those made specially for FM reception work well in suburban areas. Some feature electronic "tuning" and amplification circuits for better reception.

An ordinary rooftop VHF TV antenna provides excellent FM reception. An inexpensive "splitter" permits you to use the TV and FM at the same time with very little signal loss.

In extremely weak reception areas, a special outdoor antenna may be the only solution. Such antennas can receive stations up to 175 miles (280km) away over flat terrain.

Many new homes and apartments have built-in 75 ohm antenna lead-in systems. Your Receiver is designed to be used with either 300 ohm or 75 ohm type antenna systems. See the antenna connection drawings at the right of page 2; the shield portion of the 75 ohm cable must be connected to the GND screw.

For AM, a long piece of wire strung outdoors between two insulators can greatly increase AM long-distance reception. Or use Radio Shack's 278-758.

NOTE: To protect your receiver use a lightning arrestor on any outdoor antenna.

Connecting an L-Pad

In some cases you may want to vary the volume of the remote, or rear, speakers separately. This can be done very simply and inexpensively with a stereo L-pad, such as Radio Shack Catalog Number 40-979.

In the Quatravox mode the relative volume of the front and rear speakers is pre-set for most speaker arrangements. If you have an unusual room set-up or speakers of different types, an L-pad on either front or rear speakers can optimize your system's sound.

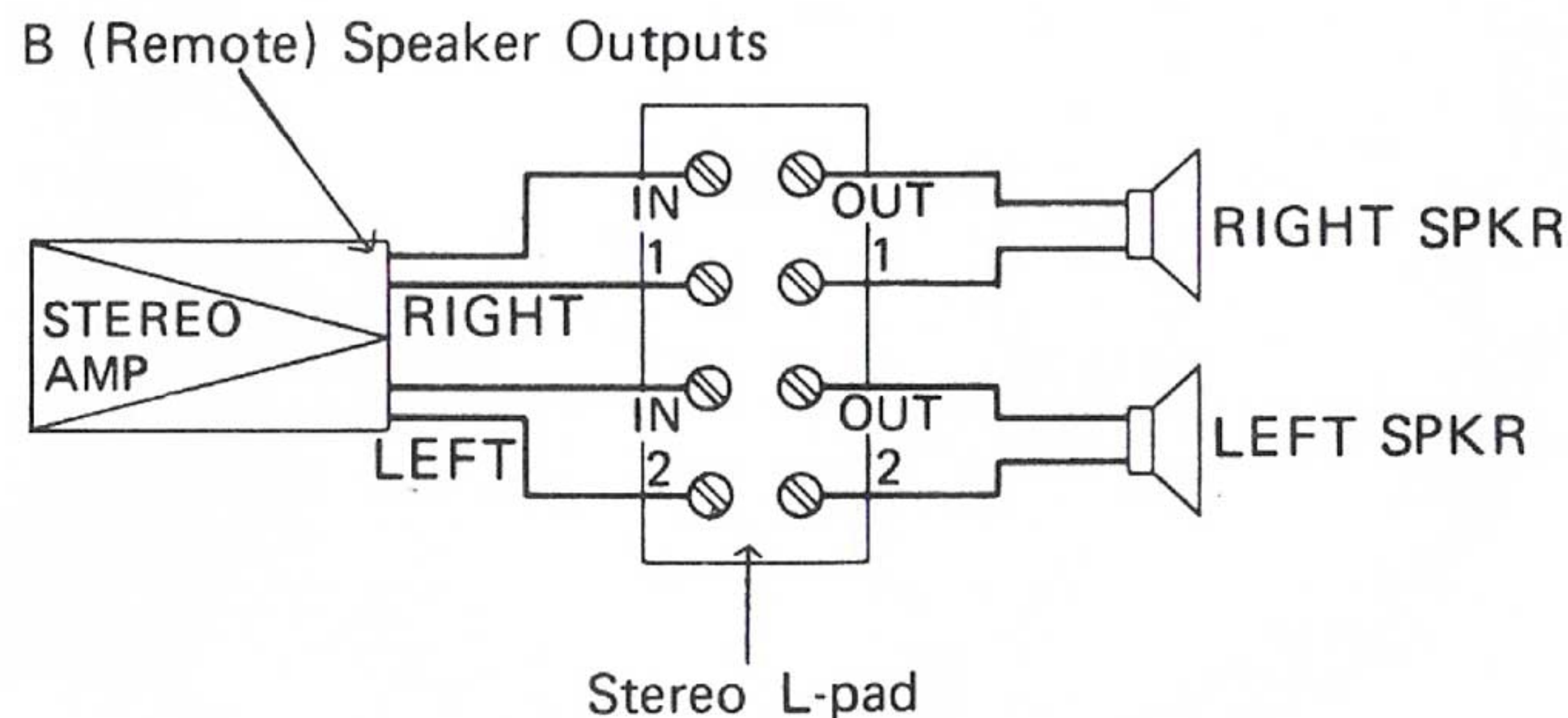

CARING FOR YOUR STA-77A

Headphones

Any stereo system can benefit from a good pair of stereo headphones. They provide the convenience of private listening and many people find the heightened stereo effect of headphones very exciting. Stop by your Radio Shack store to hear some of the headphones we sell — you'll be pleasantly surprised.

The STA-77A will accept any low impedance headphone through its front panel jack. Through its speaker outputs it will drive even the finest electrostatic headsets.

Notes on Tape Recorder Care

A clean, demagnetized recorder will give its best performance for many years, while a dirty recorder can mangle or ruin pre-recorded tapes in a very short time.

An inexpensive demagnetizer (degausser) removes residual magnetism from the tape heads. This will insure the lowest possible hiss and distortion and the best possible high frequency response. Always clean and demagnetize your recorder before making critical recordings. Under normal conditions you should demagnetize your recorder after every 10–15 hours of play.

With normal use you should clean the heads and metal tape guides once or twice a month with a special solvent such as Realistic Recorder Cleaner (catalog number 44-1010). Moisten a clean cotton swab with fluid and rub the heads with short circular movements. Then clean oxide deposits from all metal tape guides. There are also a number of cloth cleaning tapes which can be played like a tape for fast, easy cleaning.

You can even use your demagnetizer to help remove oxide particles trapped deep in the head gaps. Place a cleaner-moistened cotton swab over the gap and bring the demagnetizer into contact with it. Move the swab and demagnetizer in short, circular sweeps. Gradually withdraw the demagnetizer and remove the dirty swab.

Yearly preventive maintenance by an authorized technician reduces the possibility of expensive major breakdown and will keep your recorder in peak operating condition.

The STA-77A's real-wood veneer should be polished from time to time with lemon oil (available from Radio Shack). Waxing produces a glossy finish but it tends to build up and produces a dull coating.

Treat the front panel with care — so you don't scratch it. A window cleaning liquid works well (a small amount on a soft cloth).

VENTILATION—can be important. We merely recommend that you don't place the STA-77A on a surface which would block air circulation — air must be able to circulate freely around the back, under and over the top of the case. Avoid placing on a shag rug, etc. which would block such circulation.

If You Have Problems

We hope you don't; but if you do, here are some suggestions:

1. Check all your cable connections. Make sure all the leads and plugs are secure **at both ends**.
2. Try a different AC outlet if you don't get any indication of power (and be sure you've got the line cord plugged in!).
3. Try interchanging cables and connections on the rear panel — sometimes this will give you a hint of where the problem lies — and may solve the problem for you.
4. If the dial scale lights and pointer lights are on and Meter works — but you have no sound — make sure you didn't leave TAPE MON pressed in! If that is not the case — maybe the automatic overload protection circuit has activated. In such a case, turn off POWER and check your speaker connections.
 - A. Make sure there is no short across the speaker screw terminals (stray strand of wire touching between terminals or to the metal chassis).
 - B. If you are using more than one pair of speakers, they must be 8 or 16 ohm type (two pair of 4 ohm speakers can overload the amplifier circuit and cause this circuit to activate).
 - C. Let the Receiver cool down for a few minutes and then turn POWER back on.
5. If the dial lights don't come on, the fuse may be blown. Check it; replace only with a 3 Amp type.

In any case, if none of the above does the job and you still have a problem — help is as close as your local Radio Shack store. Bring your unit in and be ready to describe the symptoms — we will get you back into good stereo sound ASAP!

NATURAL SOUND *REALISTIC*[®] SPEAKER SYSTEMS

Solo[™] Series



Optimus[®] Series

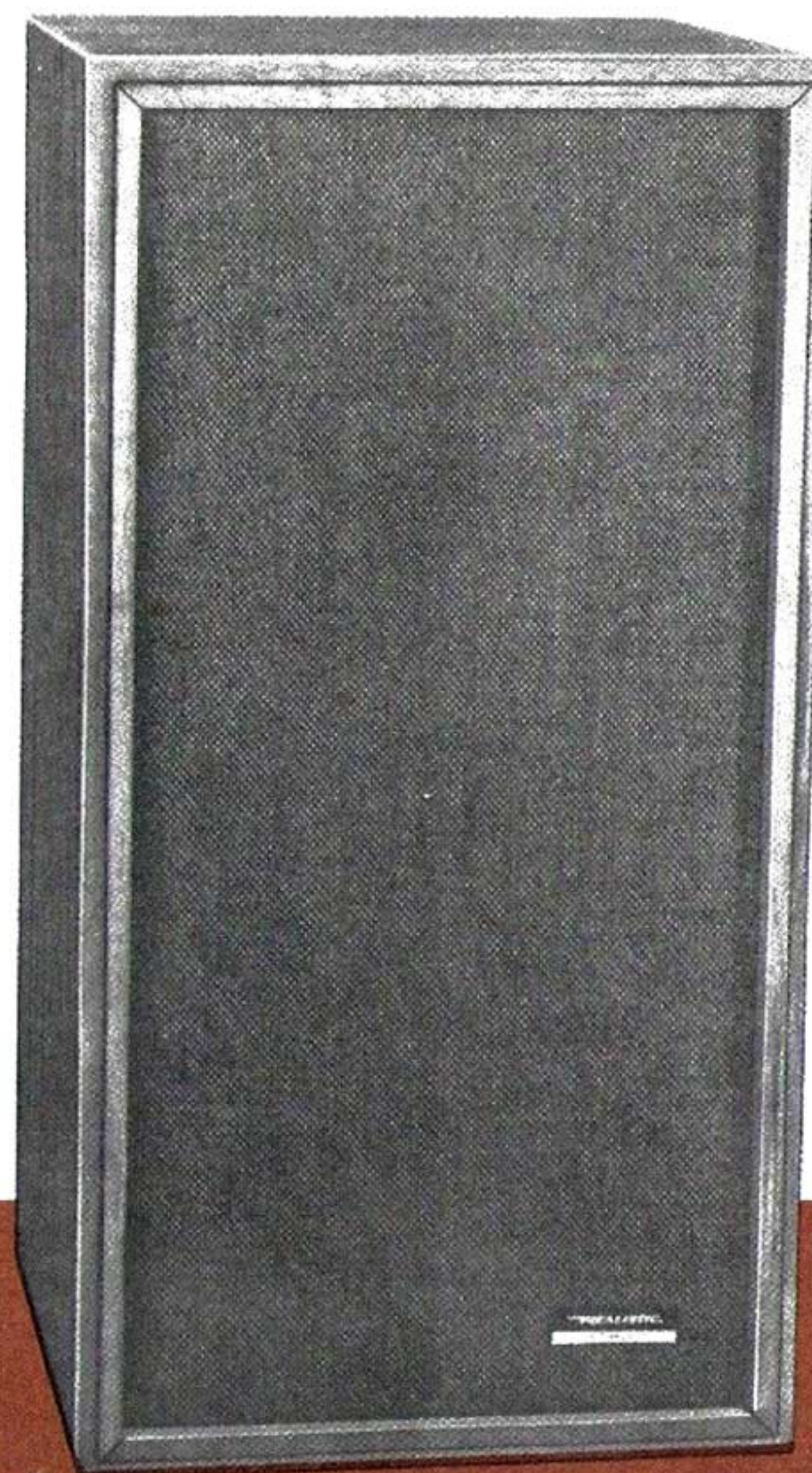

Over 1,000,000 Realistic loudspeakers have been sold in recent years through the nationwide Radio Shack chain. Since the development of its widely acclaimed electrostatic tweeter, Realistic has had an enviable reputation for building good speakers at lower than usual prices. Our Solo, Optimus, Nova, Mach and Minimus Series all have a 5-year warranty. Every speaker is engineered by us, not just "a box with a label." And though speakers are meant to be heard and not seen, every Realistic speaker is born as beautiful as it sounds. Choose from over 20 different models.

Minimus[®] Series



RADIO SHACK  A DIVISION OF TANDY CORPORATION

U.S.A.: FORT WORTH, TEXAS 76102
CANADA: BARRIE, ONTARIO, CANADA L4M 4W5

TANDY CORPORATION

AUSTRALIA

280-316 VICTORIA ROAD
RYDALMERE, N.S.W. 2116

BELGIUM

PARC INDUSTRIEL DE NANINNE
5140 NANINNE

U. K.

BILSTON ROAD
WEDNESBURY, STAFFS WS10 7JN