

# Service Manual

**PIONEER®**

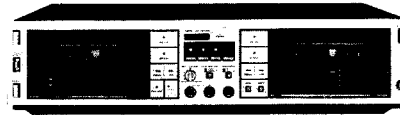

**REPAIR & ADJUSTMENTS**



**ORDER NO.  
ARP-266-0**

**STEREO DOUBLE CASSETTE TAPE DECK**

# CT-1040W

MODEL CT-1040W COMES IN SIX VERSIONS DISTINGUISHED AS FOLLOWS:

Type	Voltage	Remarks
KU	AC120V only	U.S.A. model
HE	AC220V, 240V (switchable)	European continent model
HB	AC220V, 240V (switchable)	United Kingdom model
HP	AC220V, 240V (switchable)	Australia model
D	AC120V, 220V, 240V (switchable)	General export model
D/G	AC120V, 220V, 240V (switchable)	U.S. Military model

- This service manual is applicable to the CT-1040W/KU. For servicing of the other types, please refer to page 56.
- For the circuit and mechanism descriptions, please refer to the CT-1040W, CT-X8W service manual (ARP-370).
- Ce manuel d'instruction se réfère au mode de réglage, en français.
- Este manual de servicio trata del método de ajuste escrito en español.

## CONTENTS

1. SPECIFICATIONS .....	2	9. ELECTRICAL PARTS LIST .....	31
2. FRONT PANEL FACILITIES .....	3	10. ADJUSTMENTS .....	35
3. DISASSEMBLY .....	6	RÉGLAGE .....	42
4. PARTS LOCATION .....	8	AJUSTE .....	49
5. EXPLODED VIEW AND PARTS LIST .....	10	11. SAFETY INFORMATION .....	55
6. PACKING .....	20	12. SUPPLEMENT FOR HE, HB AND HP TYPES .....	56
7. P.C. BOARD CONNECTION DIAGRAM .....	21	13. SUPPLEMENT FOR D AND D/G TYPES .....	59
8. SCHEMATIC DIAGRAM .....	27		

**PIONEER ELECTRONIC CORPORATION** 4-1, Meguro 1-Chome, Meguro-ku, Tokyo 153, Japan  
**PIONEER ELECTRONICS (USA) INC.** 1925 E. Dominguez St., Long Beach, California 90810 U.S.A.  
**PIONEER ELECTRONIC (EUROPE) N.V.** Keetberglaan 1, 2740 Beveren, Belgium  
**PIONEER ELECTRONICS AUSTRALIA PTY. LTD.** 178-184 Boundary Road, Braeside, Victoria 3195, Australia

# 1. SPECIFICATIONS

System .....	Compact cassette, 2-channel stereo
Heads .....	"Hard Permalloy" recording/playback head x 1 "Hard Permalloy" playback head x 1 "Ferrite" erasing head x 1 "Ferrite" dummy erasing head x 1
Motor .....	2-speed DC servo motor x 2
Wow/Flutter .....	No more than 0.045% (WRMS) No more than ± 0.17% (DIN)
Fast Winding Time .....	Approx. 110 seconds (C-60 tape)
Frequency Response	
- 20 dB recording:	
Normal tape .....	25 to 15,000 Hz (35 to 14,000 Hz ± 3 dB)
Chrome tape .....	25 to 15,500 Hz (35 to 15,000 Hz ± 3 dB)
Metal tape .....	25 to 17,000 Hz (35 to 16,500 Hz ± 3 dB)
Signal-to-Noise Ratio	
Dolby NR OFF .....	More than 57 dB
Noise Reduction Effect	
Dolby type B NR ON .....	More than 10 dB (at 5 kHz)
Harmonic Distortion .....	No more than 1.0% (0 dB)
Input (Sensitivity)	
MIC (L, R) .....	1.4 mV, 6 mm diam. jack (Source impedance 11.7 kΩ)
LINE (INPUT) .....	50.7 mV (Input impedance 71 kΩ)
Output (Reference level)	
LINE (OUTPUT) .....	450 mV (Output impedance 2.8 kΩ)
Headphones .....	0.25 mW (Load impedance 8 Ω)

## SUBFUNCTIONS

- One-touch recording
- Built-in Dolby B type noise reduction system
- Full electronic auto-stop mechanism
- IC-based full logic control
- Headphones jack
- Auto tape selector function
- Relay play function for continuous playback
- Synchro recording start function
- Tape copying function (from Deck A to Deck B)
- Pitch control function (Deck A)
- Automatic music search function (Deck A)
- Timer standby function (Deck B)
- REC muting function
- Double-speed tape copying
- Phono synchro mechanism (D and D/G models only)
- Automatic level control
- LED level meter

## MISCELLANEOUS

Power Requirements	
KU, KC models .....	AC 120 V, 60 Hz
HE, HB, HP models .....	AC 220/240 V, 50/60 Hz
D, D/G models .....	AC 120/220/240V, 50/60 Hz (switchable)
Power Consumption	
KU, KC models .....	28 watts
HE, HB, HP models .....	33 watts
D, D/G models .....	24 watts
Dimensions .....	420 (W) x 101.5 (H) x 315 (D) mm 16-9/16 (W) x 4 (H) x 12-6/16 (D) in
Weight (without packaging) .....	7.2 kg (15 lb 14 oz)

## FURNISHED PARTS

Operating instructions .....	1
Connection cord with pin plug .....	2

## NOTES:

1. Reference Tapes:  
Normal & LH: DIN 44513/BLATT6 or equiv.  
CrO<sub>2</sub> DIN 45513/BLATT7 (CrO<sub>2</sub>) or equiv.
2. Reference Recording Level: Meter 0 dB indicating level (160 nwb/m magnetic level = Philips cassette reference level)
3. Reference Signal: 315 Hz
4. Wow & Flutter: • JIS (3 kHz, with acoustic compensation (weighted) rms value); DIN 3,150Hz with acoustic compensation (weighted) PEAK value DIN 45507
5. Frequency Response: • Measured at - 20 dB level, DOLBY NR OFF, level deviation is ± 6 dB without indication.
6. Signal-to-Noise Ratio: • Measured at 3rd harmonic distortion 3% level, weighted (DIN 45513/BLATT7)
7. Sensitivity: Input level (mV) required for reference recording level with input (REC) level control set to maximum
8. Maximum Allowable Input: While decreasing settings of input (REC) level controls and increasing level at input jacks, this is the maximum input level (mV) at the point where recording amplifier OUTPUT waveform becomes clipped.
9. Reference Output Level: Playback output level when meter indicates 0 dB.
10. This model does not employ a recording/playback connector (DIN-type).

## NOTE:

*Specifications and the design are subject to possible modifications without notice due to improvements.*

## 2. FRONT PANEL FACILITIES

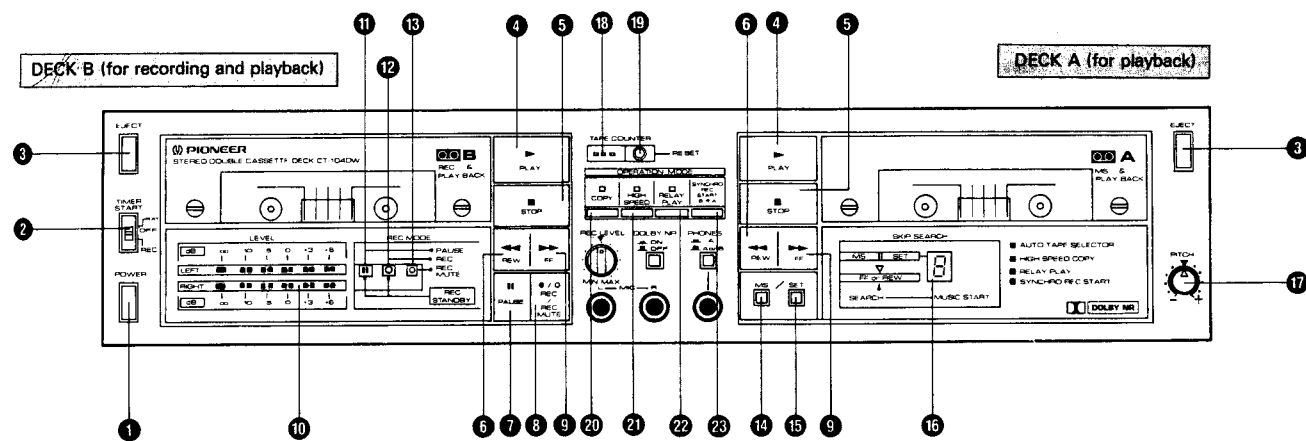

### 1 POWER SWITCH

The power is switched on when this switch is pressed to the "in" position. Release the switch to turn off the power.

- After the switch is set to the ON position, the muting circuit is activated and so the unit will not operate for about 4 seconds.
- When the POWER switch is set to OFF while the tape deck is operating, the operational mode is released and the unit is set to the stop mode.
- When the POWER switch is set to ON while the TIMER switch is at the REC or PLAY position, the recording or playback mode is established automatically. Make sure that the TIMER switch is at OFF when an unattended recording or wake-up playback operation is not to be performed.

### 2 TIMER START SWITCH

This is operated for unattended recording or wake-up playback using an optional audio timer. *Timer playback/recording is a function of Deck B. Deck A cannot be used for timer playback/recording.*

**PLAY:** Set here so that the unit's power is switched on at the time preset on the audio timer and so that the unit is automatically set to the playback mode.

**OFF:** Set here when the audio timer is not being used.

**REC:** Set here so that the unit's power is switched on at the timer preset on the audio timer and so that the unit is automatically set to the recording mode.

### 3 EJECT BUTTON

The cassette door opens when this button is pressed. Do not press it when the tape is traveling or while the recording or playback mode has been temporarily suspended.

### 4 PLAY SWITCH (▶)

Depress this switch to playback a tape.

### 5 STOP SWITCH (■)

Depress this switch to stop the tape travel and to release the operating switches.

### 6 REW SWITCH (◀◀)

Depress this switch to rewind the tape at high speed (The tape will travel from right to left).

### 7 PAUSE SWITCH

Press to temporarily stop the tape transport in the playback or recording mode. At times like this, the pause indicator (■) lights. When pressed again, the pause function is released and the tape starts to travel again. The switch does not function in the fast forward or rewind modes. When it is pressed in the stop mode, the pause indicator lights; when it is pressed again, the unit is reset to the stop mode and the tape does not move.

### 8 REC/REC MUTE SWITCH

This switch functions as both the recording switch and record muting switch. When pressed, the unit is set to the recording mode and when it is kept depressed, it functions as the recording mute switch.

#### Recording switch

Press the switch when recording sound onto the tape. The REC (●) indicator now lights. If the accidental erasure prevention tabs on the cassette shell have been broken out or the tape has not been loaded, the unit will not be set to the recording mode even if this switch is pressed. Press the stop switch (■) to release the recording mode.

#### Recording mute switch

When this switch is pressed during recording, unrecorded blanks can be created for as long as the switch is kept depressed. While depressed, the REC MUTE indicator (●) lights. Use this switch for efficient editing of tapes with sufficient blanks between the programs and for providing the unrecorded blanks which are required to operate the index scan, music search/skip, music repeat and blank search accessory functions.

*The recording mute switch is not lock and so functions only while it is kept in depressed position. When pressed during a recording, no unrecorded blanks are created and so the switch should not be pressed unless absolutely necessary.*

### 9 FF SWITCH (▶▶)

Depress this switch to send the tape forward at high speed (The tape will travel from left to right).

### 10 LEVEL METERS

These indicate the input level during recording and the output level during playback.

### 11 PAUSE INDICATOR (■)

This lights when the unit is set to the pause mode.

### 12 RECORDING INDICATOR (●)

This lights when the unit is set to the recording mode.

### 13 RECORDING MUTE INDICATOR (○)

This lights while the REC MUTE switch is pressed during a recording.

### 14 MUSIC SEARCH SWITCH (MS)

Use this switch when playing a tape with music recorded on it to quickly locate the beginning of songs separated by a non-recorded section of over 4 seconds duration. In the fast-forward mode or rewind mode, when this switch is set to ON, tape travel will stop in the non-recorded area between songs and the unit is automatically set to the playback mode. This is a handy function for locating the program. *The music search function belongs to Deck A.*

### 15 SET SWITCH

Press this switch to skip programs on a tape when searching for the program you want to hear. When it is pressed by a number of times equivalent to the number of programs which are to be skipped on the tape, this number is displayed on the set indicator.

### 16 MS SET INDICATOR

The number of programs on the tape to be skipped is indicated here. When the MS SET switch is pressed, a number not exceeding "9" appears on this indicator.

### 17 PITCH CONTROL

This can be used to vary the tape speed of Deck A across a  $\pm 6\%$  range. The speed increases when the control is rotated clockwise (↻) and reduced when rotated counterclockwise (↺); the musical intervals are made higher or lower, respectively. The standard speed is obtained at the control's center clickstop position (▼). Use the control to adjust the speed when adjusting the intervals with mixing recording or playback or when playing back a tape recorded on another tape deck on your own deck.

#### NOTE:

*Set this control to the clickstop position (▼) when using the music search or skip search function. If it is left rotated clockwise, it will not be possible to detect the unrecorded blanks between the programs on the tape during fast forwarding or rewinding operations.*

### 18 TAPE COUNTER

This indicates the transport position of the tape loaded in Deck B with a 3-digit number.

### 19 RESET BUTTON

Depressing this button resets the tape counter to "000". Depress this button before recording or playback to reset the counter to "000". If you make a memo of the tape contents and corresponding tape counter numbers during recording and playback, you will have an index of the programs on the tape enabling you to conveniently find any desired program on the tape.

### 20 COPY SWITCH

"Copying" refers to the process of transferring the recorded contents on a pre-recorded tape onto another tape. The pre-recorded tape is loaded into Deck A and its contents are recorded onto Deck B when this switch is pressed. When the switch is pressed, the 29 indicator lights. Tape copying cannot be performed from Deck B to Deck A.

### 21 HIGH SPEED SWITCH

This switch is used to select normal tape speed or double tape speed for tape copying. The 30 indicator lights up to indicate double speed. Release the switch when copying tapes at the normal tape speed.

### 22 RELAY PLAY SWITCH

Press this switch for relay play. When pressed, the 31 indicator lights. When the tape loaded in one deck has finished playing and the tape comes to the end, the tape in the other deck automatically starts playback. Relay play is possible from Deck A to Deck B and vice versa.

### 23 SYNCHRO REC START SWITCH

The playback tape is loaded into Deck A while the recording tape is loaded into Deck B. When this switch is pressed, Deck A is automatically set to the playback mode and Deck B is automatically set to the recording mode, and the tapes start to move simultaneously. Use this switch for tape copying.

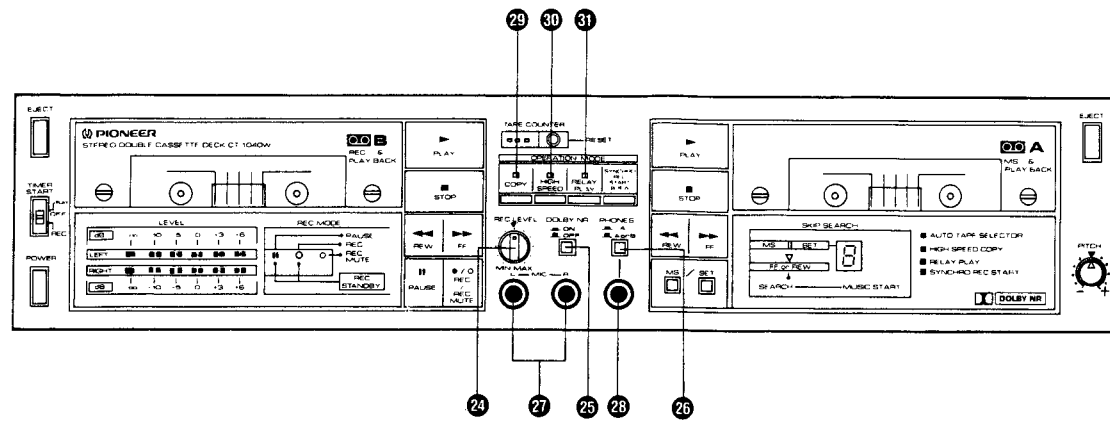

**24 RECORDING LEVEL CONTROL**

This control is used to adjust the input from the rear panel REC terminals and the MIC jack. When rotated clockwise (↻), the recording level is increased; when rotated counterclockwise (↺), the level is reduced. The standard input level is obtained when the control is set to the center clickstop position (▼).

**25 \*DOLBY NR SWITCH**

Press this switch to the ON (■) position when recording material with the Dolby noise reduction system or when playing back a tape which has been recorded with the system. Release the switch to the OFF (□) position when recording material without the Dolby system or when playing back a tape which has not been recorded with the system.

• If you make a note on the tapes of material recorded with the Dolby system, there will be less chance that the DOLBY NR switch will be set to the wrong position during playback.  
 • When a recording has been made with the system, ensure that it is played back with the system. Proper sound will not be reproduced if a tape recorded with the Dolby system is played back with the switch at the OFF position or if a tape recorded with the switch at the OFF position is played back with the Dolby system.

\*The word "Dolby" and are trademarks of Dolby Laboratories Licensing Corporation. Noise Reduction System manufactured under license from Dolby Laboratories Licensing Corporation.

**26 PHONES SWITCH**

While a tape is playing back in Deck B, the programs played back on Deck A can be heard through headphones. This function is used when preparing the next program for your friends to sing along with, for instance. Refer to the table for the rear panel PLAY terminal output with Deck A and Deck B playback and for the headphone jack output when the phones switch is selected.

DECK A	DECK B	PLAY TERMINAL OUTPUT	PHONES SWITCH POSITION	PHONES JACK OUTPUT
Playback	Playback	Deck B output	A or B (■)	Deck B output
Playback	Playback	Deck B output	A (□)	Deck A output
Playback	—	Deck A output	A or B (■)	Deck A output
Playback	—	Deck A output	A (□)	—
—	Playback	Deck B output	A or B (■)	Deck B output
—	Playback	Deck B output	A (□)	—

**27 MIC JACKS**

These are the input jacks for microphone recording. Plug the left channel microphone into the L jack and the right channel microphone into the R jack.

**28 HEADPHONE JACK**

This is the output jack for the stereo headphones. Plug the headphones into this jack to monitor the quality of a recording or to listen to a tape privately.

NOTE:  
Use headphones with a low impedance. Sufficient volume will not be obtained with high-impedance headphones.

**29 COPY INDICATOR**

This lights when the COPY switch is pressed.

**30 HIGH SPEED INDICATOR**

This lights when the HIGH SPEED switch and COPY switch are pressed.

**31 RELAY PLAY INDICATOR**

This lights when the RELAY PLAY switch is pressed.

**3. DISASSEMBLY**

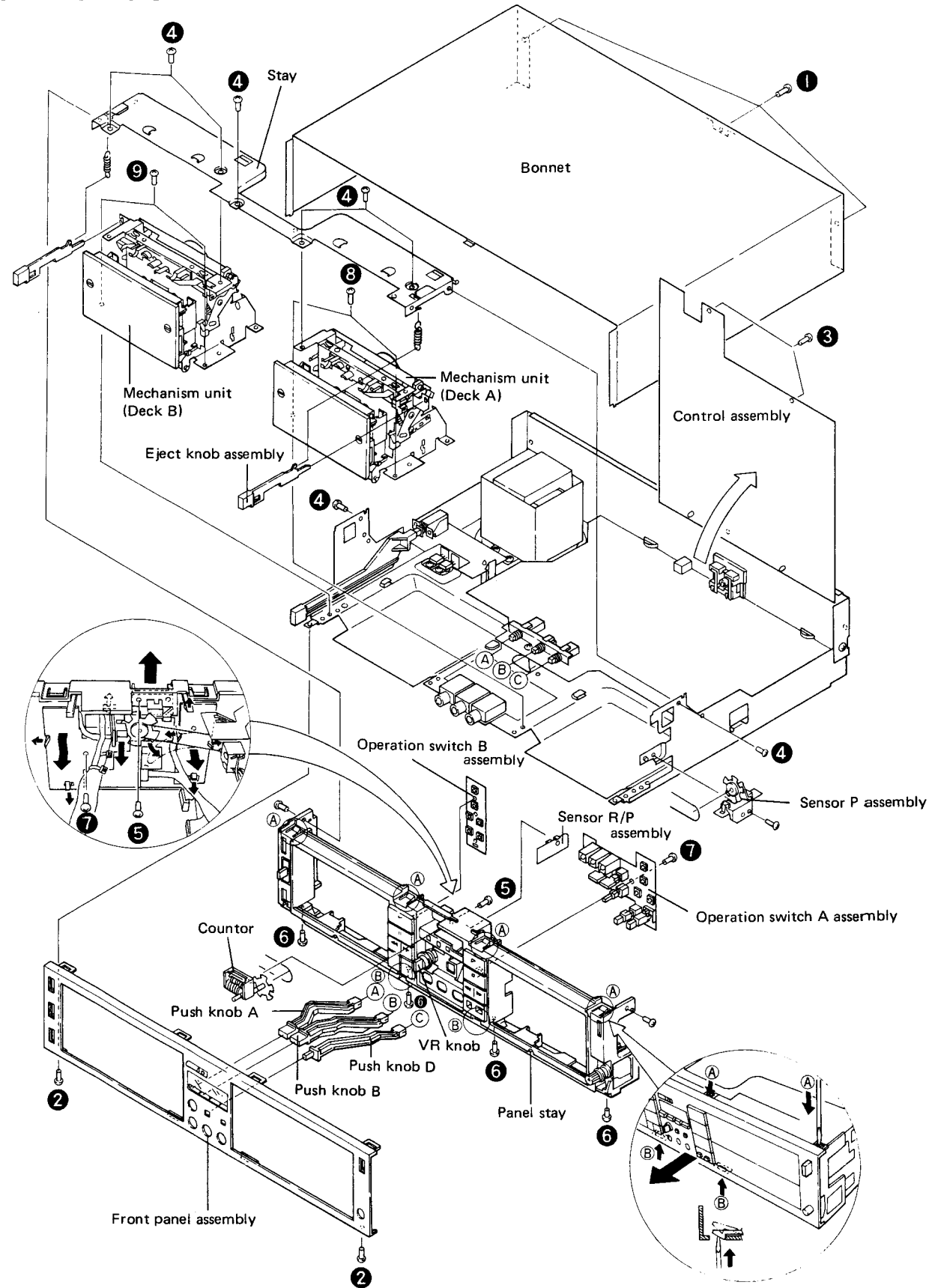

Fig. 3-1 Disassembly

**Disassembly Procedures**

1. Undo screws ❶ to remove the bonnet.
2. Undo screws ❷, and using a screwdriver push panel stay hooks A (four positions along the top) and hooks B (two positions along the bottom) to remove the front panel assembly.
3. Undo screws ❸ to open the control unit and expose the adjustment locations.
4. Undo screws ❹ to remove the stay.
5. Undo screws ❺ to remove the counter.
6. Pull push-knobs A, B and C forward and undo screws ❻ to remove the panel stay.
7. Undo screws ❼ and disengage the hook to remove the operation switch A unit.
8. Undo screws ❽ and ❾ to remove the mechanism units (deck A and deck B).

## 4. PARTS LOCATION

- Parts without part number cannot be supplied.
- The  $\Delta$  mark found on some component parts indicates the importance of the safety factor of the part. Therefore, when replacing, be sure to use parts of identical designation.
- For your Parts Stock Control, the fast moving items are indicated with the marks **★★** and **★**.  
**★★ GENERALLY MOVES FASTER THAN ★.**  
*This classification shall be adjusted by each distributor because it depends on model number, temperature, humidity, etc.*

### Front Panel View

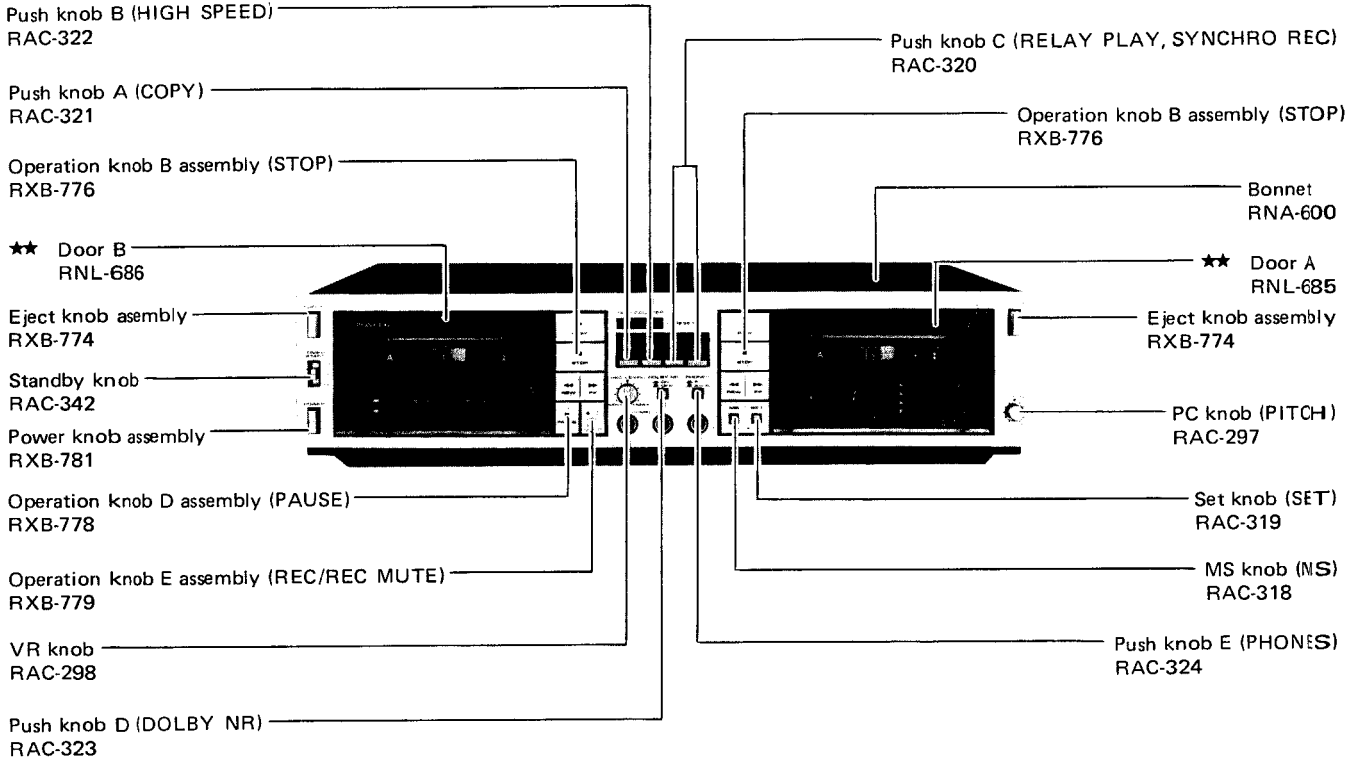

### Front View with Front Panel Removed

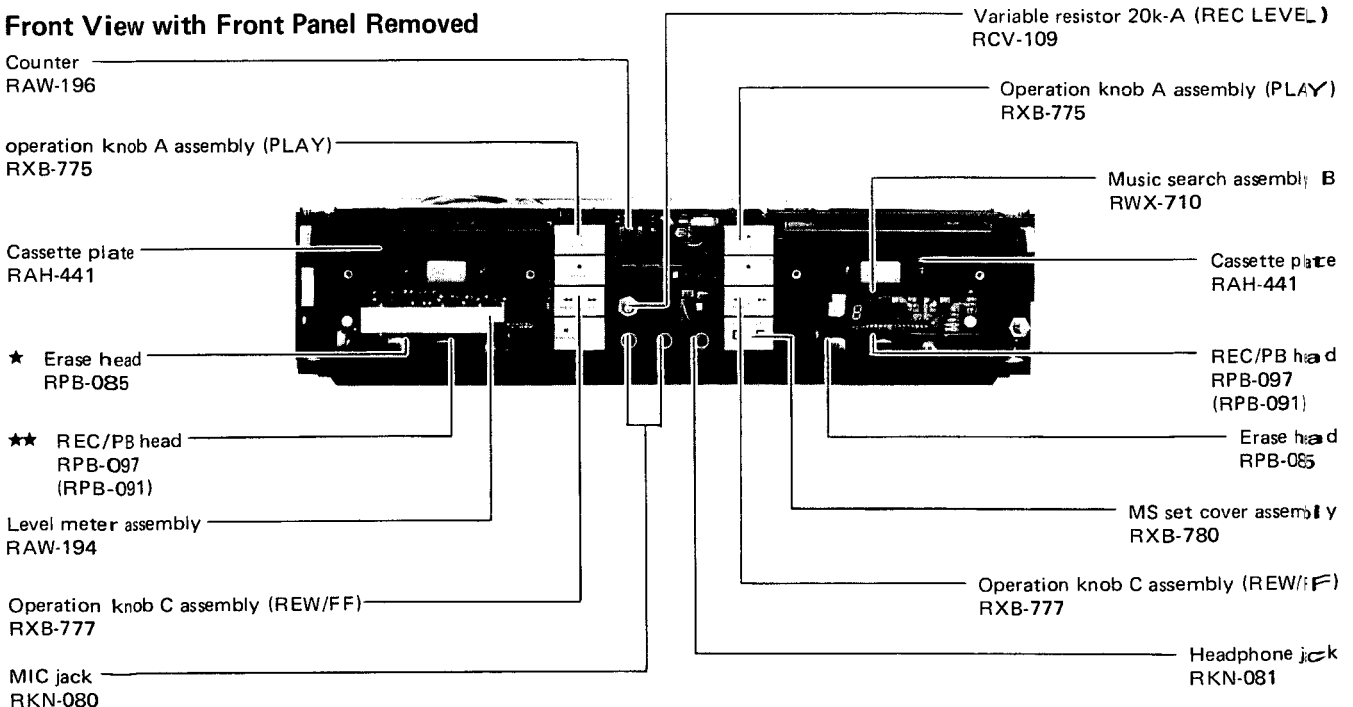

**Top View with Bonnet Removed**

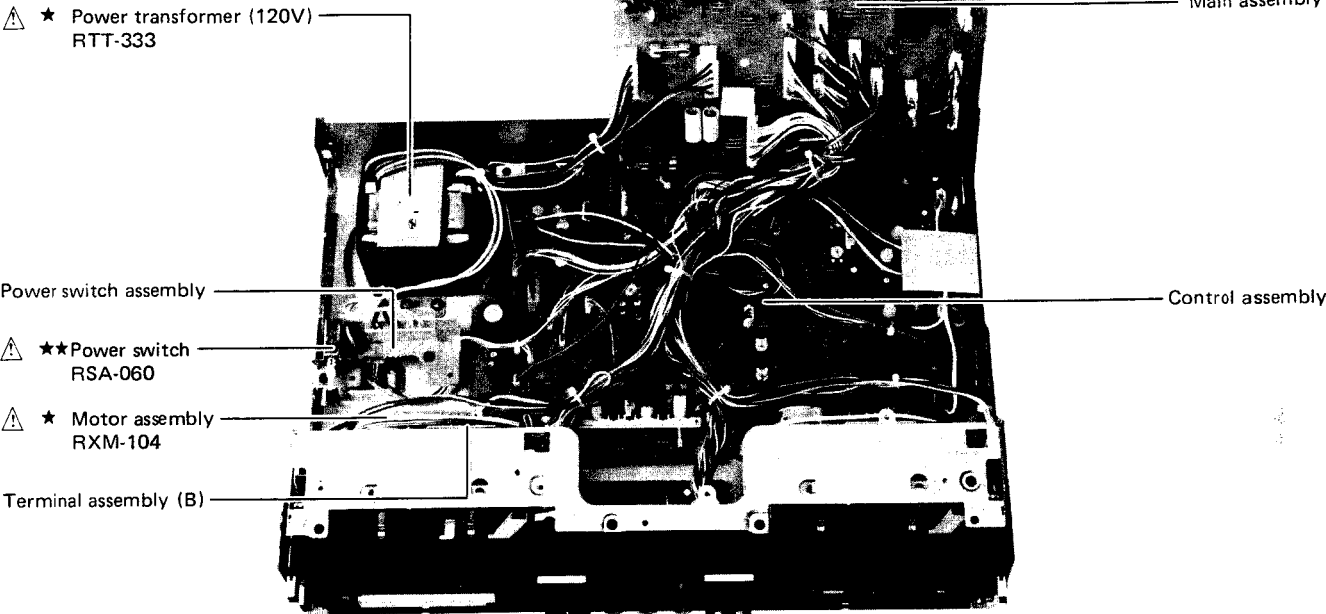

**Rear Panel View**

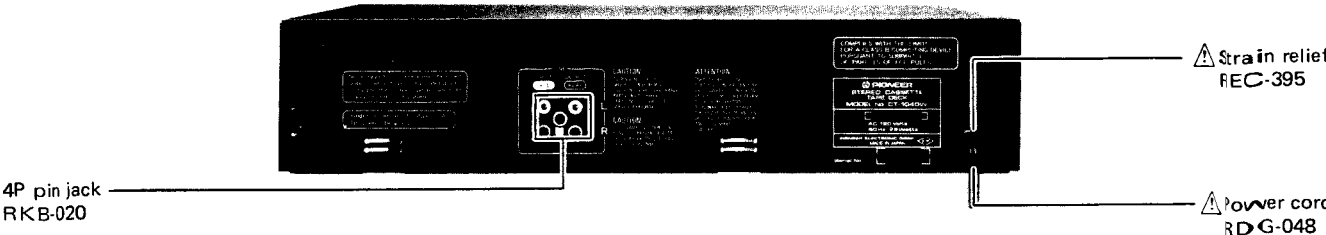

## 5. EXPLODED VIEW AND PARTS LIST

### 5.1 MAIN

- Parts without part number cannot be supplied.
- The  $\triangle$  mark found on some component parts indicates the importance of the safety factor of the part. Therefore, when replacing, be sure to use parts of identical designation.
- For your Parts Stock Control, the fast moving items are indicated with the marks **★★** and **★**.  
**★★ GENERALLY MOVES FASTER THAN ★**  
*This classification shall be adjusted by each distributor because it depends on model number, temperature, humidity, etc.*

Mark	No.	Part No.	Description	Mark	No.	Part No.	Description
	1.	RBM-002	Nylon rivet		36.	RAC-324	Push knob E
	2.	RBH-989	Operation spring		37.	RXB-781	Power knob assembly
	3.	RBH-990	Eject spring		38.	RKP-854	Connector assembly 5P
	4.	RXB-772	Sensing holder assembly		39.	REC-369	Foot assembly
	5.	RBF-062	Washer		40.	RBA-081	Screw
	6.	RNL-755	Sensing pully		41.	RKB-020	4P pin jack
	7.	RAW-196	Counter		42.	RKP-804	Connector assembly 12P
	8.	RAW-194	Level meter assembly		43.	RSG-152	Push switch assembly
	9.	RWX-710	Music search assembly B		44.	RKP-803	Connector assembly 13P
$\triangle$ ★	10.	RTT-333	Power transformer (120V)		45.	RKP-814	Connector assembly 2P
$\triangle$ ★	11.	RDG-048	Power cord		46.	RKP-747	Board in connector 3P
$\triangle$	12.	REC-395	Strain relief		47.	RKP-748	Board in connector 3P
	13.	RXX-402	Front panel assembly		48.	RKP-749	Board in connector 3P
	14.	RNL-684	Lens		49.	RKN-081	Headphones jack
	15.	REE-081	Paper		50.	RKN-080	MIC jack
	16.	RAH-441	Cassette plate		51.	RKP-750	Connector assembly 5P
	17.	RNA-600	Bonnet		52.	RKP-751	Connector assembly 3P
	18.	RXB-774	Eject knob assembly		53.	RNL-610	LED holder
	19.	RAC-342	Standby knob		54.	RSG-063	Operation switch
	20.	RNL-685	Door A		55.	RSG-143	Push switch
	21.	RNL-686	Door B		56.	RSG-150	Push switch
	22.	RXB-775	Operation knob A assembly (PLAY)		57.	RSG-153	Push switch
	23.	RXB-776	Operation knob B assembly (STOP)		58.	RKP-812	Connector assembly 3P
	24.	RXB-777	Operation knob C assembly (REW/FF)		59.	RKP-811	Connector assembly 3P
	25.	RXB-778	Operation knob D assembly (PAUSE)	★	60.	RKP-754	Connector assembly 4P
	26.	RXB-779	Operation knob E assembly (REC/REC MUTE)	★	61.	RKP-810	Connector assembly 3P
	27.	RXB-780	MS set cover assembly	★	62.	BG5524S	LED
	28.	RAC-319	Set knob	★	63.	PR5524S	LED
	29.	RAC-321	Push knob A	★	64.	RKP-809	Connector assembly 4P
	30.	RAC-322	Push knob B	★	65.	RCV-109	Variable resistor 20k-A
	31.	RAC-320	Push knob C		66.	RKP-760	Connector assembly 3P
	32.	RAC-323	Push knob D		67.	RKP-761	Connector assembly 3P
	33.	RAC-318	MS knob	★★	68.	RCS-026	Variable resistor 1k-B
	34.	RAC-298	VR knob	★★	69.	GP-411B	Photo interrupter
	35.	RAC-297	PC knob	★★	70.	RKP-808	Connector assembly 4P
				$\triangle$ ★★	71.	RKP-813	Connector assembly 3P
					72.	RSH-064	Slide switch
					73.	RKP-833	Connector assembly 3P
					74.	2SD1265	Transistor
					75.	RSA-060	Power switch

Mark	No.	Part No.	Description
	76.	RKP-834	Connector assembly 6P
	77.	RKP-774	Connector assembly 5P
	78.	RKP-775	Connector assembly
	79.	RKP-807	Connector assembly 7P
	80.	BBZ30P080FZK	Screw
	81.	VBZ40P060FMC	Screw
	82.	VBZ26P060FMC	Screw
	83.	PMZ26P040FMC	Screw
	84.	BMZ30P060FMC	Screw
	85.	RKP-520	Connector assembly 3P
	86.	RKP-684	Connector assembly 2P
	87.	RKP-709	Connector assembly 4P
	88.	RKP-298	Connector assembly 6P
	89.	RKP-769	Connector assembly 7P
	90.	RKP-770	Connector assembly 8P
	91.	AEK-073	Fuse (1.25A)
101.			Mechanism unit (Deck A)
102.			Mechanism Unit (Deck B)
103.			Main chassis
104.			Bottom plate
105.			Stay
106.			Panel stay
107.			
108.			P.C.B. stud
109.			Panel hinge
110.			Connector assembly 2P

Mark	No.	Part No.	Description
	111.		Spacer
	112.		Connector assembly 2P
	113.		Connector assembly 2P
	114.		Connector assembly 2P
	115.		Connector assembly 2P
	116.		Main assembly
	117.		Jack assembly
	118.		Operation switch A assembly
	119.		Operation switch B assembly
	120.		VR assembly
	121.		Pitch control assembly
	122.		Sensor P assembly
	123.		Sensor R/P assembly
	124.		Timer switch assembly
	125.		Transistor A assembly
	126.		Transistor B assembly
	127.		Control assembly
	128.		
	129.		Power switch assembly
	130.		

A

B

C

D

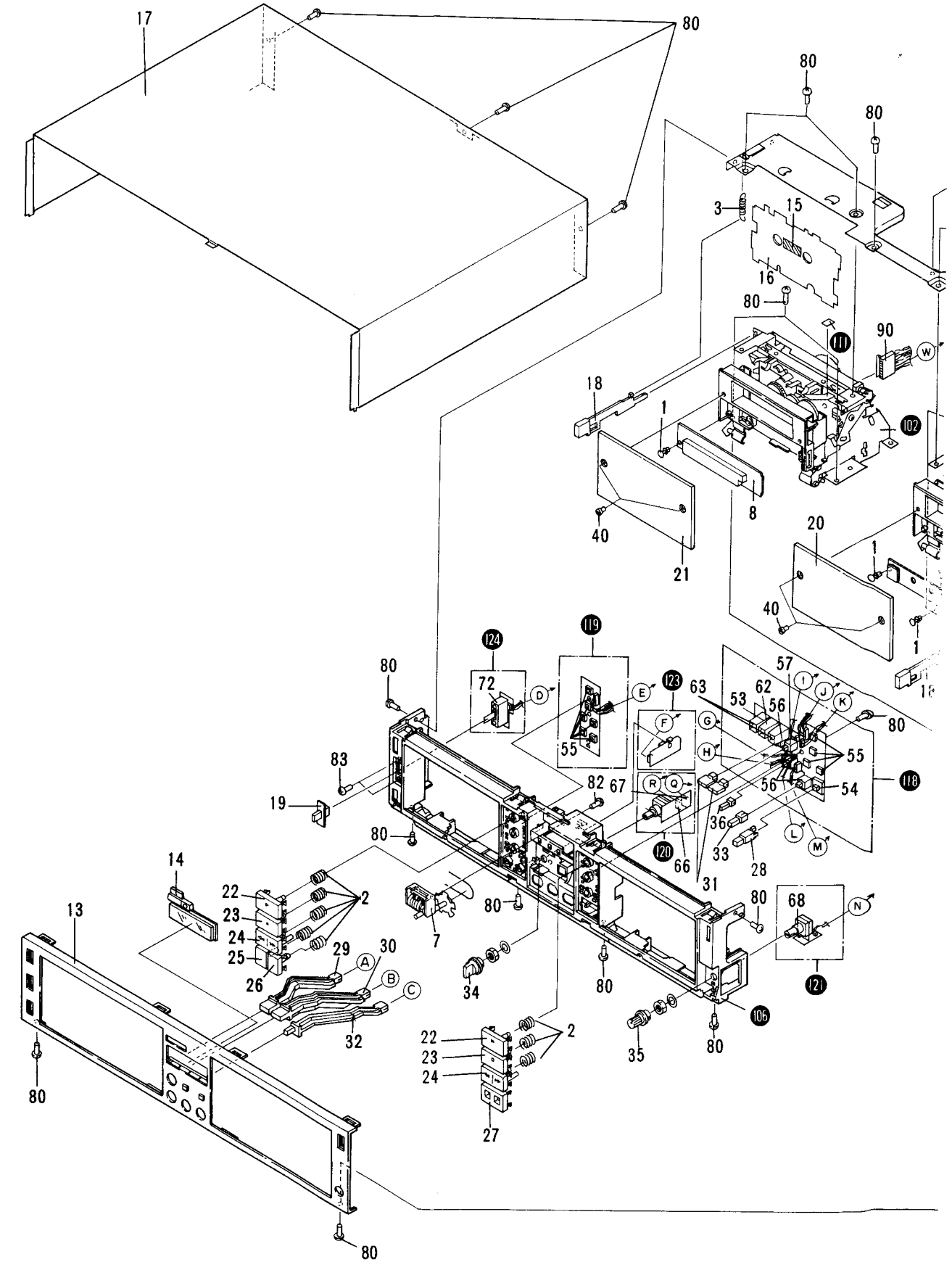

on

r assembly 2P  
 r assembly 2P  
 r assembly 2P  
 r assembly 2P

mbly  
 mbly  
 switch A assembly  
 switch B assembly  
 bly

ontrol assembly  
 assembly  
 P assembly  
 tch assembly  
 A assembly

B assembly  
 assembly  
 tch assembly

A

B

C

D

A

B

C

D

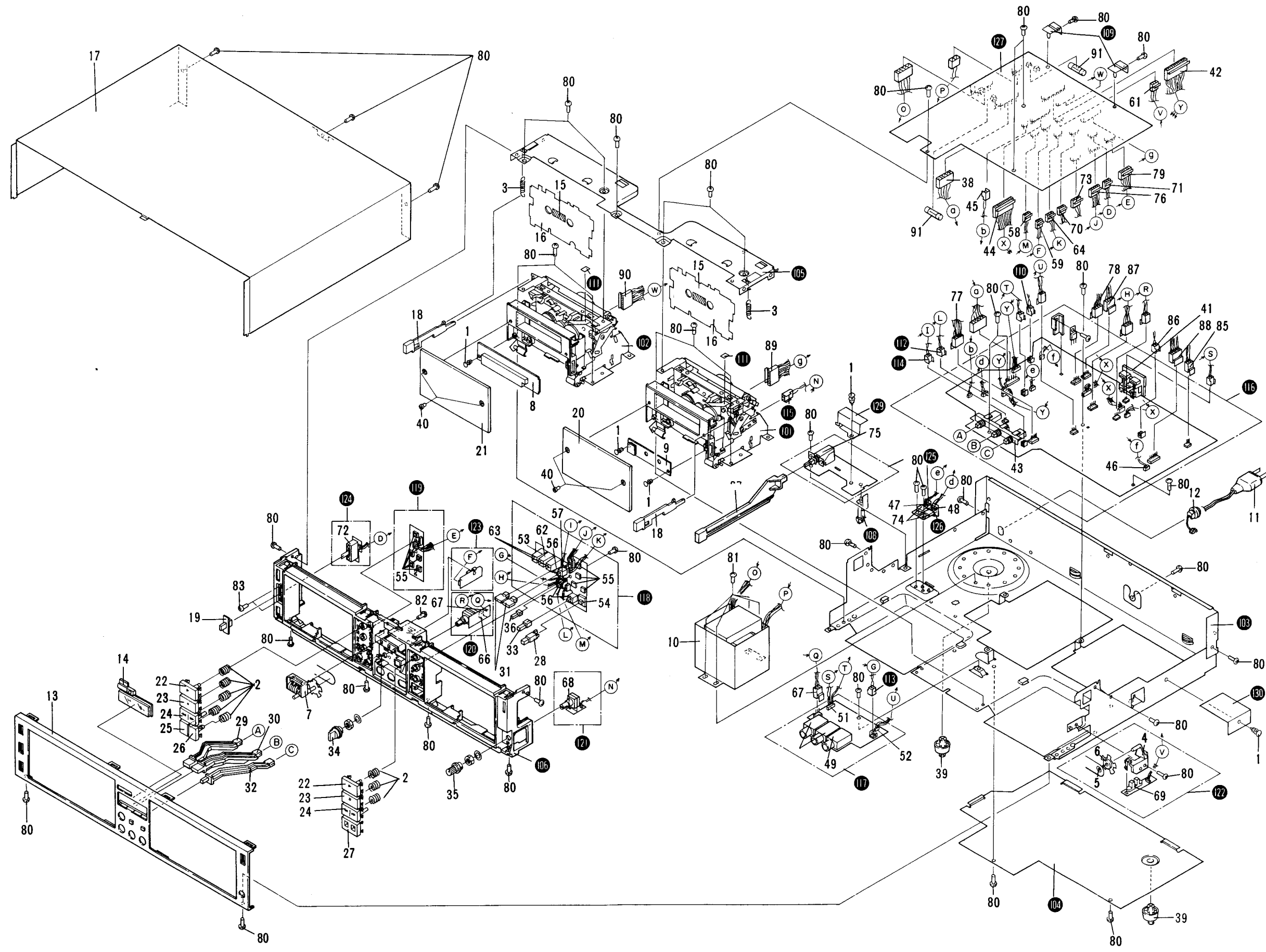

5.3 MECHANISM UNIT (DECK B)

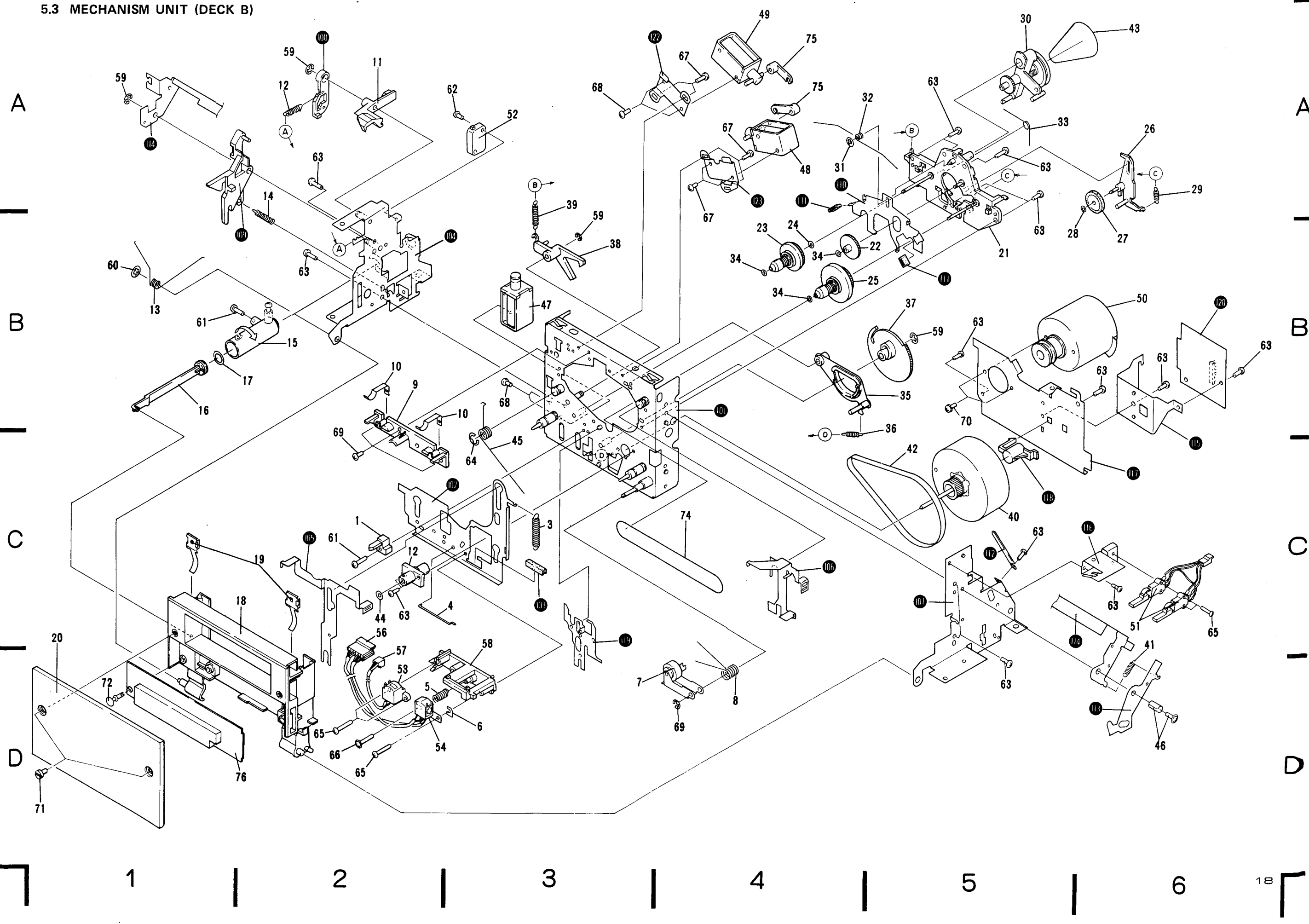

Parts  
Mark

★  
★  
★  
★

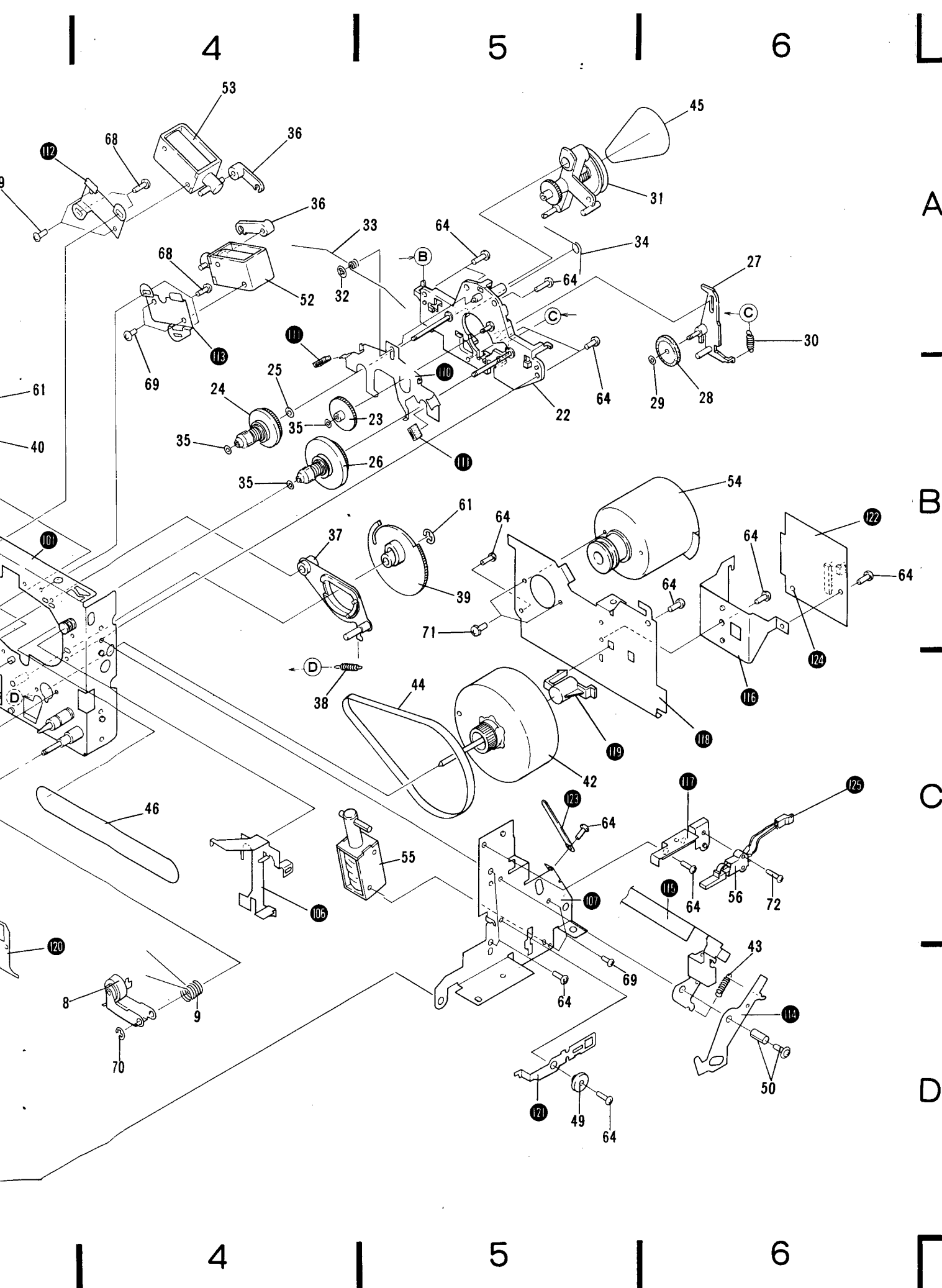

Parts list of Mechanism unit (Deck A)

Mark	No.	Part No.	Description
	1.	RNL-527	Reference pin
	2.	RXB-716	Metal holder assembly
	3.	RBH-865	HB return spring
	4.	RNL-523	Sub head base
	5.	RBH-794	HB drive spring
	6.	RBH-723	Head adjust spring
	7.	RNF-989	Spacer
	8.	RXB-720	Pinch arm assembly
	9.	RBH-890	Pinch pressure spring
	10.	RNL-524	Half holder
	11.	RNH-219	Half spring
	12.	RBH-948	Lock spring
	13.	RBH-983	Eject spring
	14.	RBH-949	Lever spring
	15.	RNL-261	Cylinder
	16.	RNL-534	Piston
	17.	REB-447	O ring
	18.	RNL-685	Door A
	19.	RNL-569	Pocket
	20.	RBK-175	Pocket spring
	21.	RWX-710	Music search assembly B
	22.	RXB-849	Reel base assembly
	23.	RNK-998	Idler gear
	24.	RXB-714	Supply reel base assembly
	25.	WA21D040D025	Washer
	26.	RXB-715	TU reel base assembly
	27.	RXB-374	Idler arm assembly
	28.	RNK-999	TU idler
	29.	WA17D032D025	Washer
	30.	RBK-724	Idler pressure spring
	31.	RXB-376	Drive arm full assembly
	32.	YS20FBT	Washer
	33.	RBH-727	Bracket spring
	34.	RBH-725	FR spring
	35.	WA17D032D025	Washer
	36.	RNL-047	Solenoid arm
	37.	RXB-723	Lever assembly
	38.	RBH-842	Lever spring
	39.	RNL-059	Cam gear
	40.	RNL-051	Gear lever
	41.	RBH-722	Gear lever return spring
	42.	RXB-717	Flywheel assembly
	43.	RBH-980	Arm spring
★	44.	REB-488	Capstan belt
★	45.	REB-495	Drive belt
★	46.	REB-355	Sensing belt
	47.	RFB-050	Oil stop washer
	48.	RBH-778	Return spring
	49.	RLB-390	Stopper
	50.	RBA-069	Screw M3 x 7

Mark	No.	Part No.	Description
△ ★	51.	RXP-134	Plunger solenoid P
△ ★	52.	RXP-135	Plunger solenoid F
△ ★	53.	RXP-136	Plunger solenoid R
△ ★	54.	RXM-104	Motor assembly
△ ★	55.	RXP-137	Plunger solenoid (PMS)
★★	56.	RSN-010	Lever switch
	57.	RPB-085	Erase head
	58.	RPB-097	REC/PB head
		(RPB-091)	
	59.	RKP-520	Connector assembly 3P
	60.	RBM-002	Nylon rivet 3 x 8
	61.	YE30FUC	Washer
	62.	YS30FBT	Washer
	63.	VCZ26P090FMC	Screw
	64.	VCZ26P060FMC	Screw
	65.	YE40FUC	Washer
	66.	PMZ20P150FMC	Screw
	67.	IMZ20Y150FMC	Screw
	68.	PMZ26P060FMC	Screw
	69.	PMX26P030FMC	Screw
	70.	YE20FUC	Washer
	71.	PMA26P040FMC	Screw
	72.	PMZ20P080FMC	Screw
	73.	RBA-081	Screw
	101.		Chassis assembly
	102.		Head bass
	103.		Shaft stopper
	104.		Side plate L assembly
	105.		Spacer
	106.		Cr O2 detect lever A
	107.		Side plate R
	108.		Lock lever
	109.		Eject lever
	110.		Brake plate
	111.		Brake shoe
	112.		Solenoid bracket R
	113.		Solenoid bracket F
	114.		Side arm
	115.		Eject plate A
	116.		P.C.B. holder
	117.		Attachment plate A
	118.		Flywheel holder
	119.		Thrust receptacle
	120.		PMS plate
	121.		Stopper lever
	122.		Terminal unit (A)
	123.		Cord holder
	124.		Binder
	125.		Connector assembly 2P

5.2 MECHANISM UNIT (DECK A)

A

B

C

D

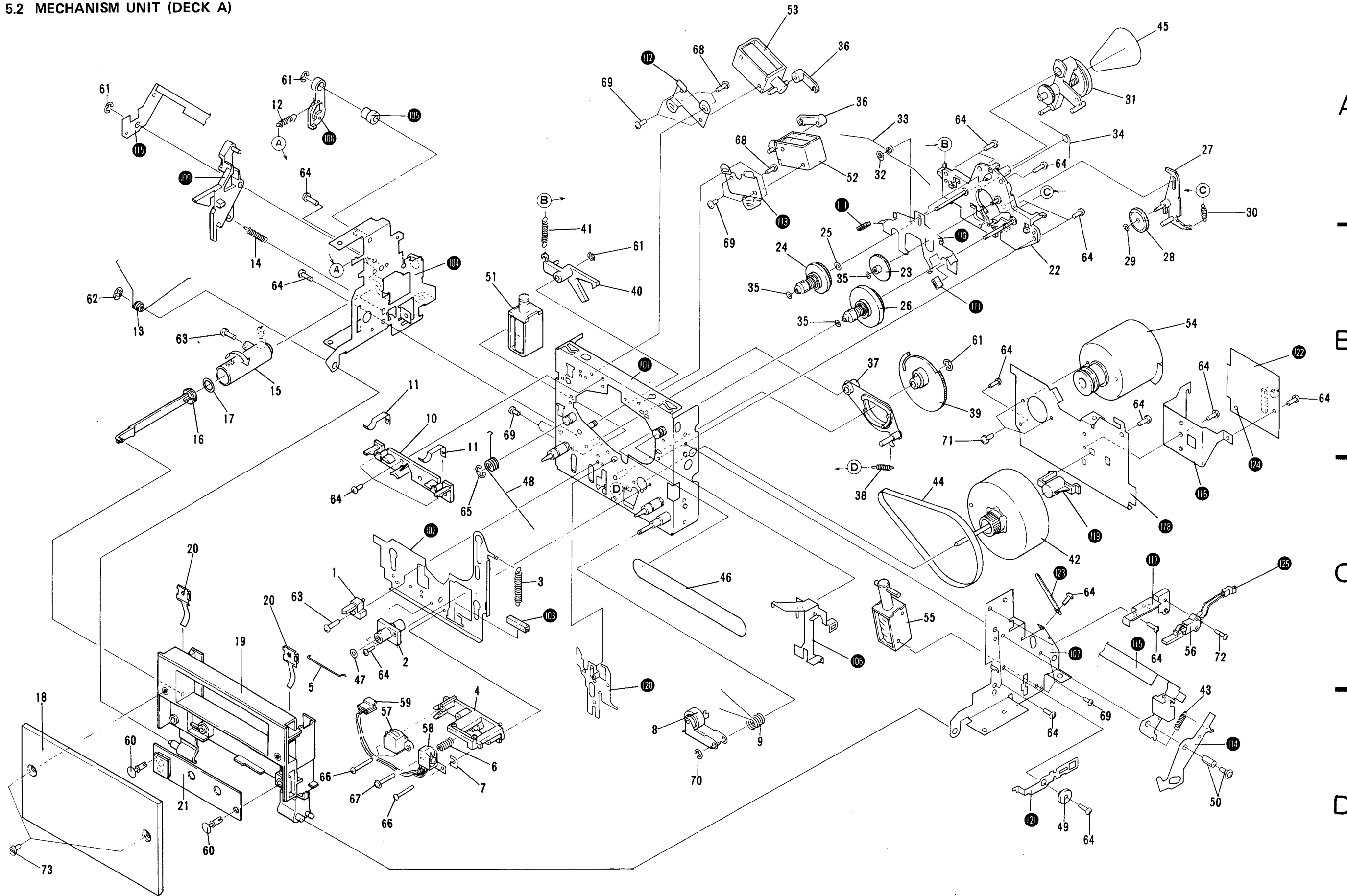

Parts list of  
Mark No.

- 1.
- 2.
- 3.
- 4.
- 5.
- 6.
- 7.
- 8.
- 9.
- 10.
- 11.
- 12.
- 13.
- 14.
- 15.
- 16.
- 17.
- 18.
- 19.
- 20.
- 21.
- 22.
- 23.
- 24.
- 25.
- 26.
- 27.
- 28.
- 29.
- 30.
- 31.
- 32.
- 33.
- 34.
- 35.
- 36.
- 37.
- 38.
- 39.
- 40.
- 41.
- 42.
- 43.
- 44. \*
- 45. \*
- 46. \*
- 47.
- 48.
- 49.
- 50.

Parts list of Mechanism unit (Deck B)

Mark	No.	Part No.	Description
	1.	RNL-527	Reference pin
	2.	RXB-716	Metal holder assembly
	3.	RBH-865	HB return spring
	4.	RBH-794	HB drive spring
	5.	RBH-723	Head adjust spring
	6.	RNF-989	Spacer
	7.	RXB-871	Pinch arm assembly
	8.	RBH-890	Pinch pressure spring
	9.	RNL-524	Half holder
	10.	RNH-219	Half spring
	11.	RNL-529	REC detect lever
	12.	RBH-948	Lock spring
	13.	RBH-983	Eject spring A
	14.	RBH-949	Lever spring
	15.	RNL-261	Cylinder
	16.	RNL-534	Piston
	17.	REB-447	O ring
	18.	RNL-569	Pocket
	19.	RBK-175	Pocket spring
	20.	RNL-686	Door B
	21.	RXB-849	Reel base assembly
	22.	RNK-998	Idler gear
	23.	RXB-714	Supply reel base assembly
	24.	WA21D040D025	Washer
	25.	RXB-715	TU reel base assembly
	26.	RXB-374	Idler arm assembly
	27.	RNK-999	TU idler
	28.	WA17D032D025	Washer
	29.	RBK-724	Idler pressure spring
	30.	RXB-376	Drive arm Full assembly
	31.	YS20FBT	Washer
	32.	RBH-727	Brake spring
	33.	RBH-725	FR spring
	34.	WA17D032D025	Washer
	35.	RXB-723	Lever assembly
	36.	RBH-842	Lever spring
	37.	RNL-059	Cam gear
	38.	RNL-051	Gear lever
	39.	RBH-722	Gear lever return spring
	40.	RXB-717	Flywheel assembly
	41.	RBH-980	Arm spring
★	42.	REB-488	Capstan belt
★	43.	REB-495	Drive belt
	44.	RFB-050	Oil stop washer
	45.	RBH-778	Return spring
△★	46.	RBA-069	Screw M3 x 7
△★	47.	RXP-134	Plunger solenoid P
△★	48.	RXP-135	Plunger solenoid F
△★	49.	RXP-136	Plunger solenoid R
△★	50.	RXM-104	Motor assembly

Mark	No.	Part No.	Description
★	51.	RSN-010	Lever switch
★★	52.	RSH-058	Slide switch
	53.	RPB-085	Erase head
	54.	RPB-097 (RPB-091)	REC/PB head
	55.	RNH-184	
	56.	RKP-298	Connector assembly 6P
	57.	RKP-526	Connector assembly 2P
	58.	RNL-523	Sub head base
	59.	YE30FUC	Washer
	60.	YS30FBT	Washer
	61.	VCZ26P090FMC	Screw
	62.	PMZ26P100FMC	Screw
	63.	VCZ26P060FMC	Screw
	64.	YE40FUC	Washer
	65.	PMZ20P150FMC	Screw
	66.	IMZ20Y150FMC	Screw
	67.	PMZ26P060FMC	Screw
	68.	PMX26P030FMC	Screw
	69.	YE20FUC	Washer
	70.	PMA26P040FMC	Screw
	71.	RBA-081	Screw
	72.	RBM-002	Nylon rivet 3 x 8
	73.		
	74.	REB-493	Counter belt
	75.	RNL-047	Solenoid arm
	76.	RAW-194	Level meter assembly
	101.		Chassis assembly
	102.		Head bass
	103.		Shaft stopper
	104.		Side plate L assembly
	105.		Metal detect lever
	106.		CrO2 detect lever
	107.		Side plate R
	108.		Lock lever
	109.		Eject lever
	110.		Brake plate
	111.		Brake shoe
	112.		
	113.		Slide arm
	114.		Eject plate B
	115.		P.C.B. holder
	116.		Attachment plate B
	117.		Flywheel holder
	118.		Thrust receptacle
	119.		PMS plate
	120.		Terminal unit (B)
	121.		Connector assembly 4P
	122.		Solenoid bracket R
	123.		Solenoid bracket L

6. PACKING

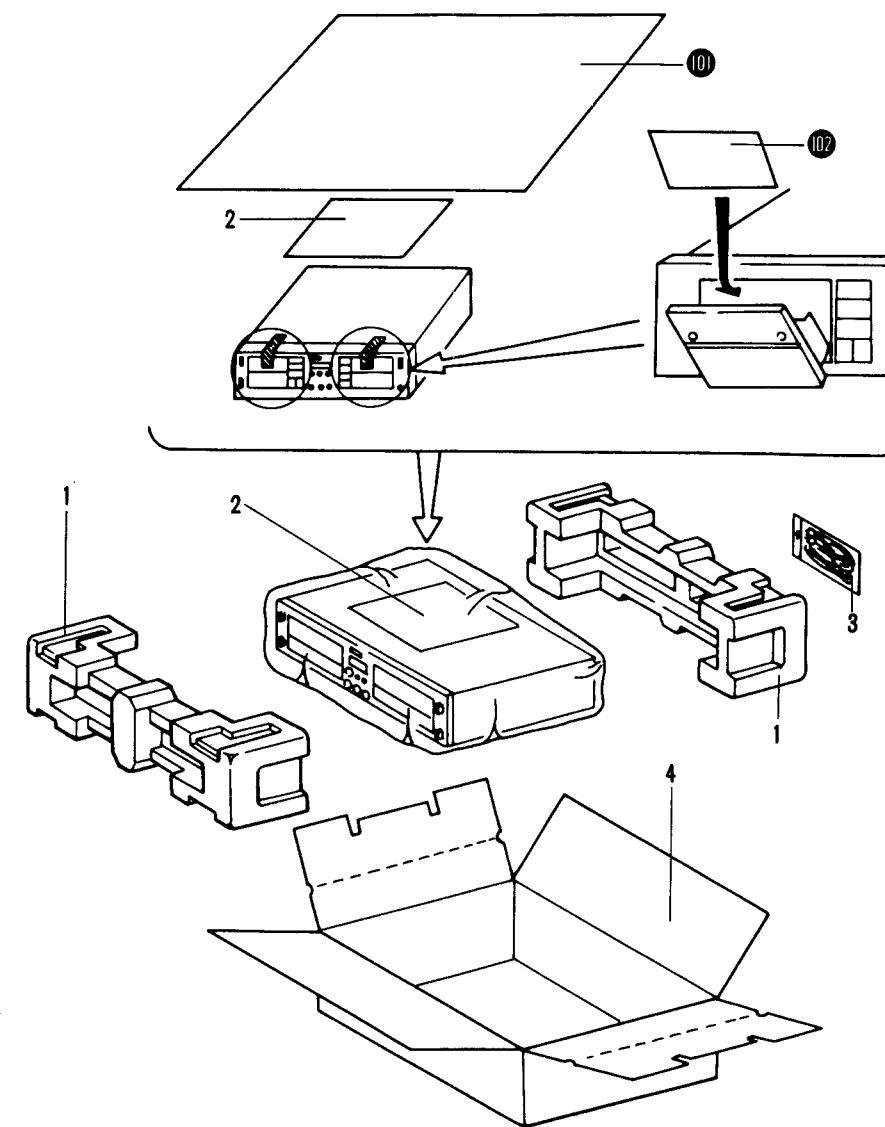

Mark	No.	Part No.	Description
	1.	RHA-254	Pad
	2.	RRB-219	Operating instructions
	3.	RDE-010	Connection cord assembly
	4.	RHG-630	Packing case
	101.		Paper
	102.		Paper



7

8

9

10

11

A

B

C

A

B

D

E

C

D

F

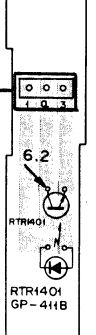
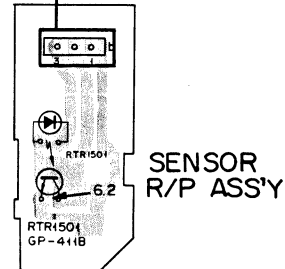
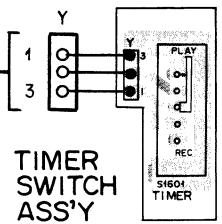
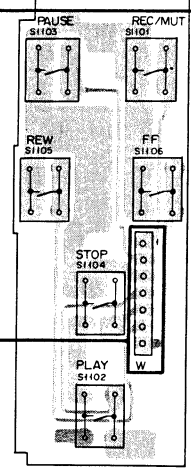
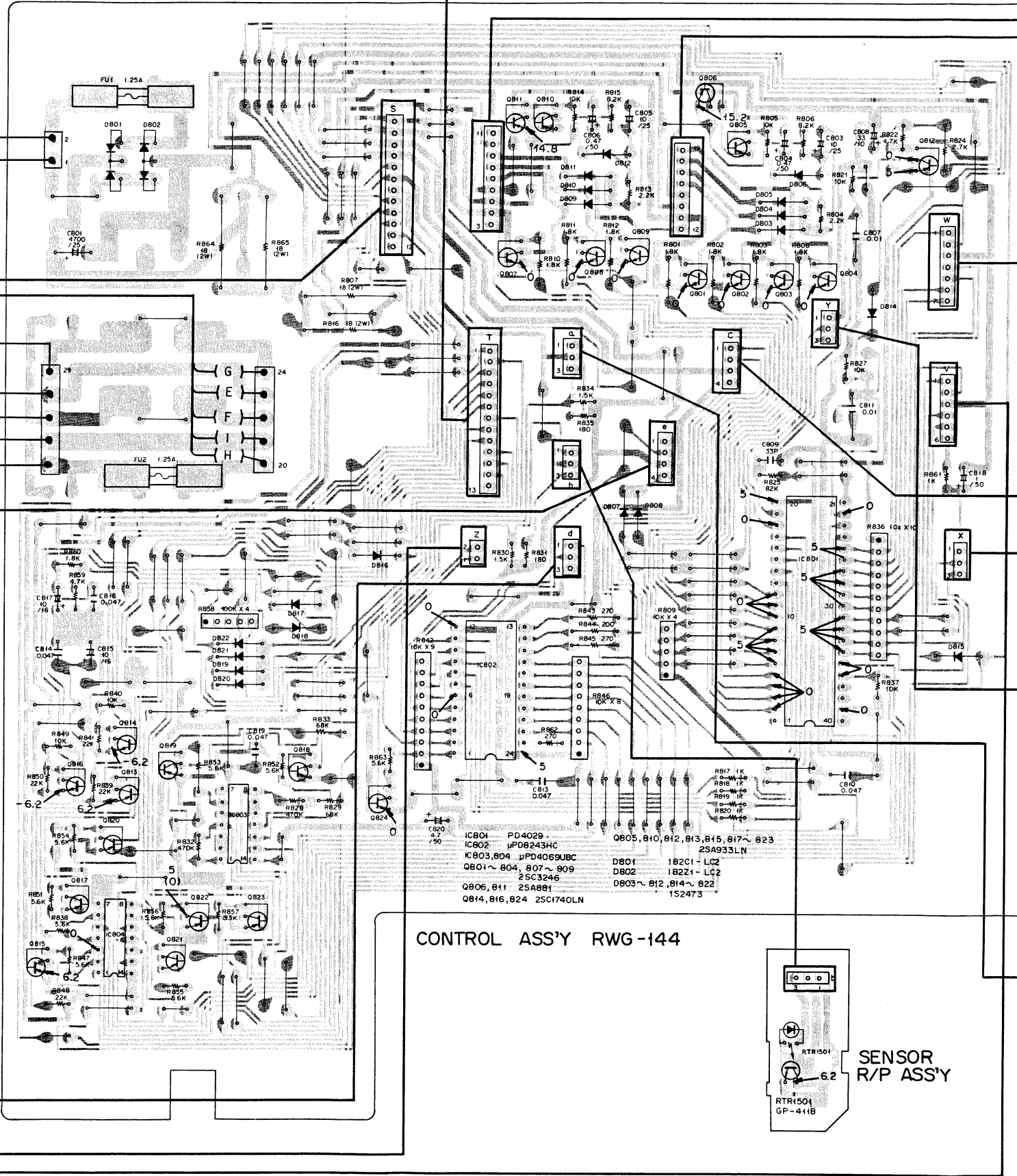
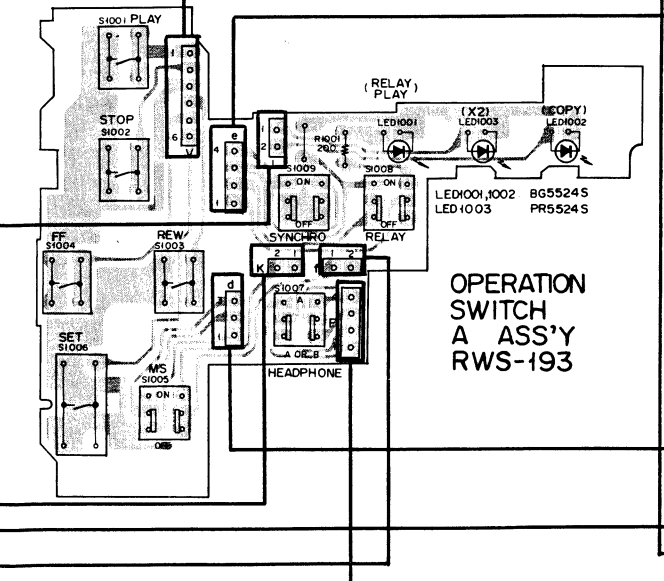
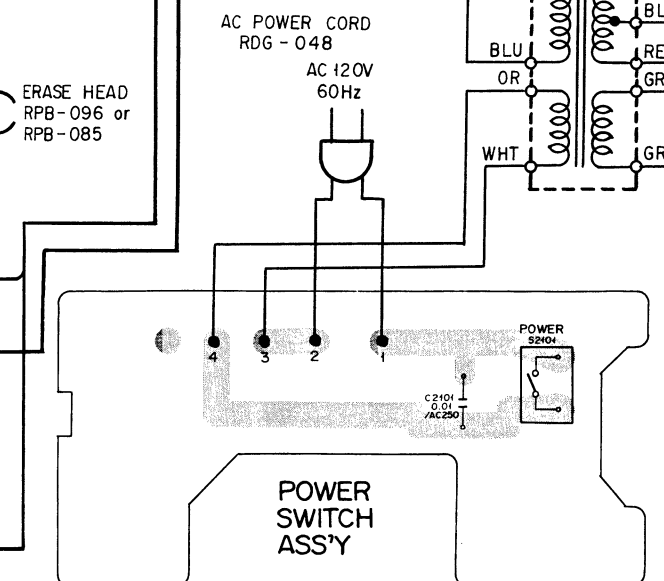
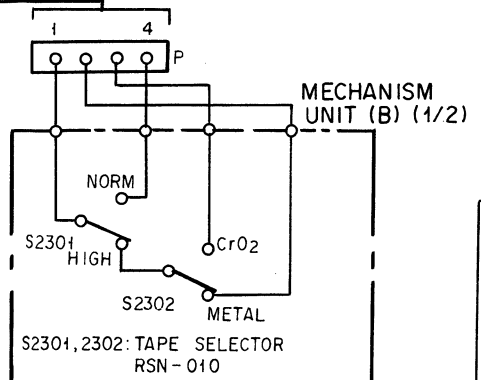

7

8

9

10

11

12

1

2

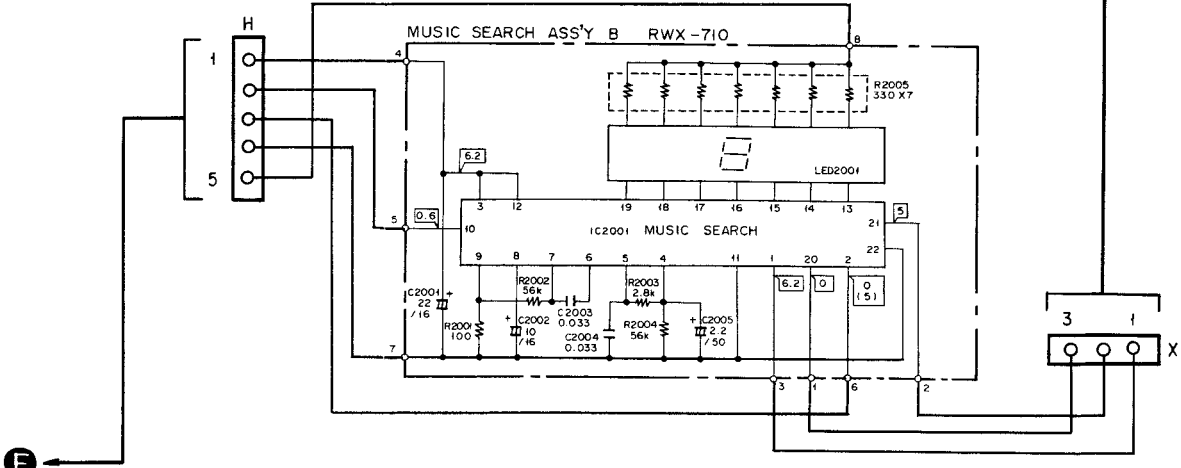
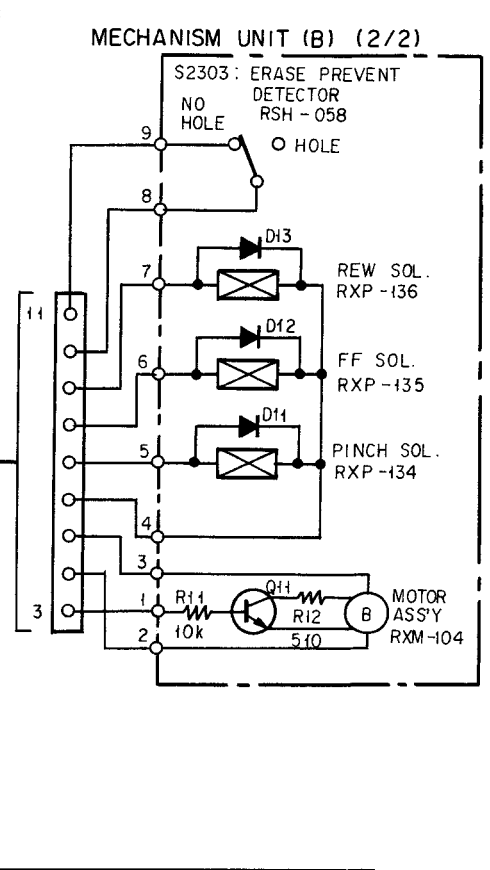
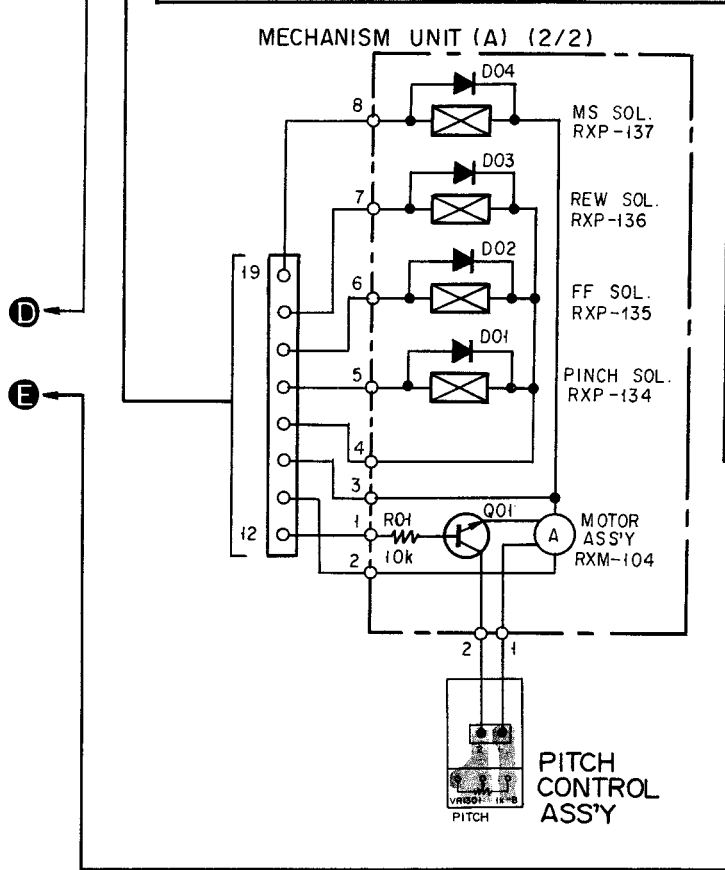
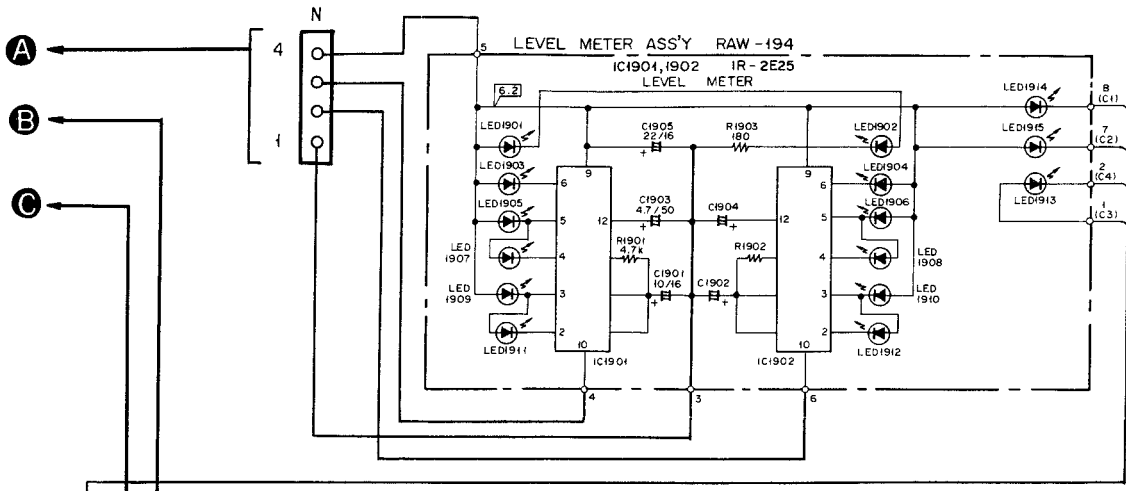

1

2

3

**2SA881**

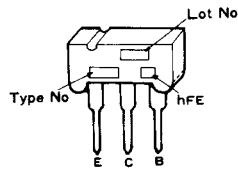

**HA11226**

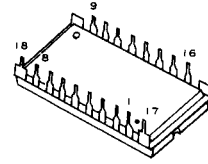

**2SA933LN  
2SC1740LN**

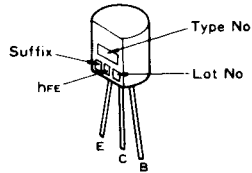

**HD14066BP  
μPD4069UBC**

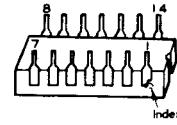

**2SC2673**

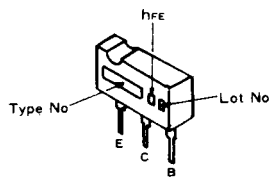

**IR2C30**

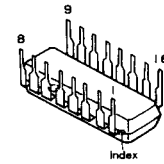

**2SC3246**

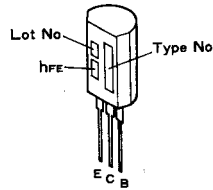

**M5218L  
M5220L**

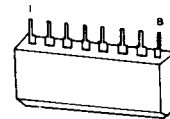

**2SD880**

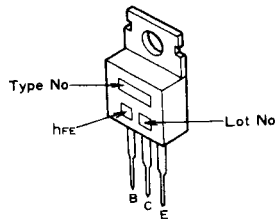

**PD4029**

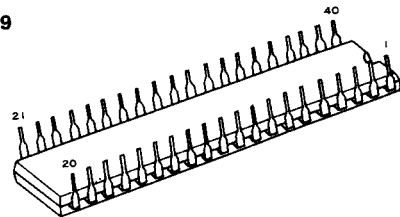

**2SD1265**

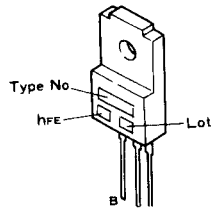

**μPD8243HC**

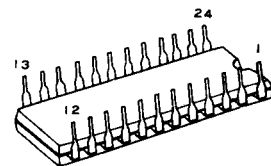

**BA328**

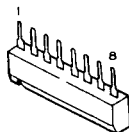

**GP-411B**

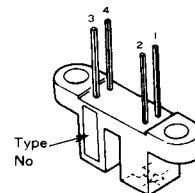



**NOTE:**  
 The indicated semiconductors are representative ones only.  
 Other alternative semiconductors may be used and are listed in the parts list.

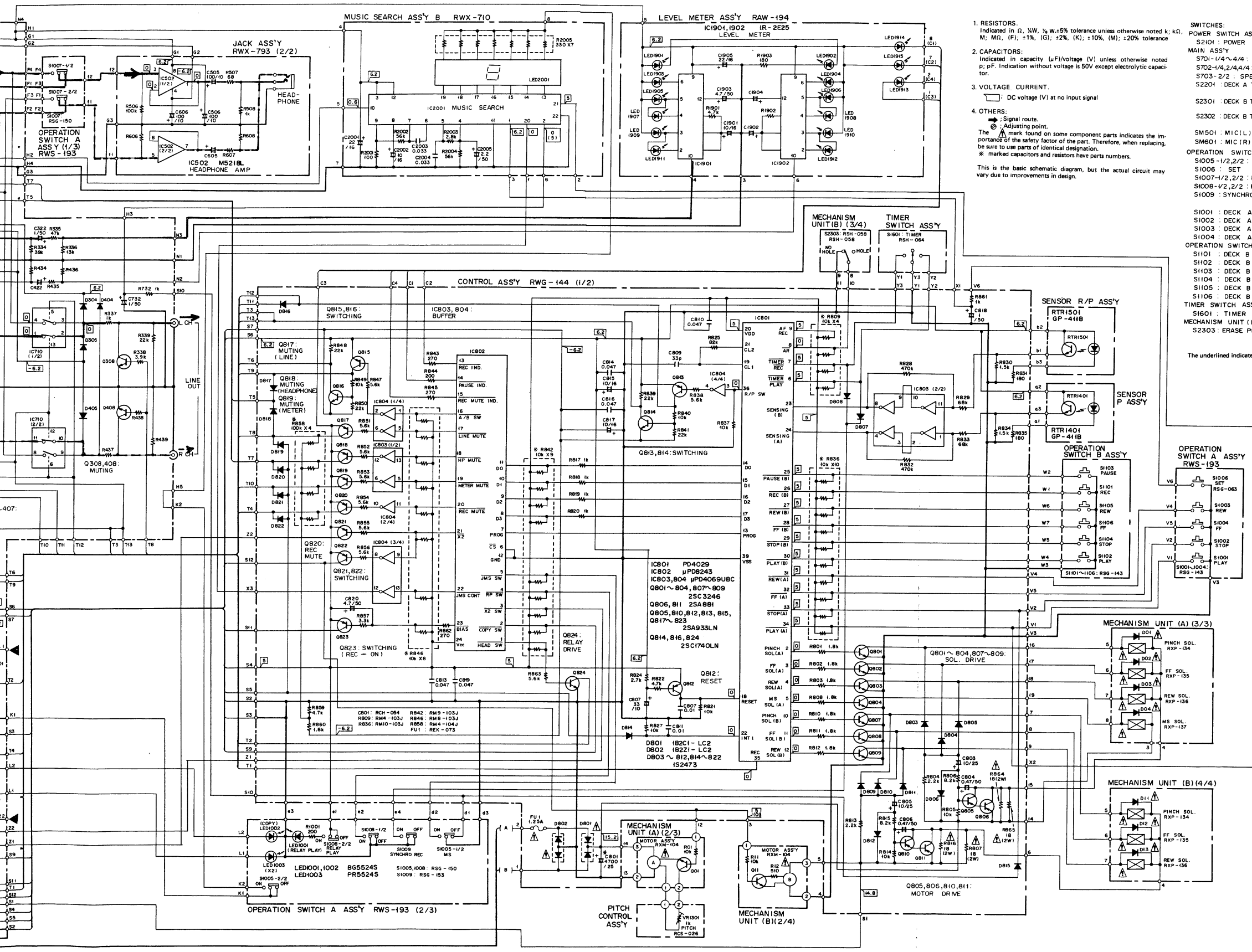

- RESISTORS:**  
 Indicated in Ω, kΩ, M, or W; ±5% tolerance unless otherwise noted; k, M, M, (F); ±1%, (G); ±2%, (K); ±10%, (M); ±20% tolerance.
- CAPACITORS:**  
 Indicated in capacity (μF)/voltage (V) unless otherwise noted; p, nF, indication without voltage is 50V except electrolytic capacitor.
- VOLTAGE CURRENT:**  
 DC voltage (V) at no input signal.
- OTHERS:**  
 Signal route.  
 Adjusting point.  
 The mark found on some component parts indicates the importance of the safety factor of the part. Therefore, when replacing, be sure to use parts of identical designation.  
 \* marked capacitors and resistors have parts numbers.  
 This is the basic schematic diagram, but the actual circuit may vary due to improvements in design.

- SWITCHES:**  
 POWER SWITCH ASS'Y  
 S2101: POWER ON - OFF
- MAIN ASS'Y**
- S701-1/4~4/4: DOLBY NR ON - OFF  
 S702-1/4,2/4,4/4 COPY ON - OFF  
 S703-2/2: SPEED ON - OFF  
 S2201: DECK A TAPE SELECTOR NORMAL - CrO<sub>2</sub> METAL  
 S2301: DECK B TAPE SELECTOR NORMAL - CrO<sub>2</sub> METAL  
 S2302: DECK B TAPE SELECTOR CrO<sub>2</sub> - METAL
- SM501: MIC (L) LINE - MIC**  
**SM601: MIC (R) LINE - MIC**
- OPERATION SWITCH A ASS'Y**
- S1005-1/2,2/2: MS ON - OFF  
 S1006: SET ON - OFF  
 S1007-1/2,2/2: HEADPHONE A - A or B  
 S1008-1/2,2/2: RELAY PLAY ON - OFF  
 S1009: SYNCHRO REC ON - OFF
- OPERATION SWITCH B ASS'Y**
- S1101: DECK B REC ON - OFF  
 S1102: DECK B PLAY ON - OFF  
 S1103: DECK B PAUSE ON - OFF  
 S1104: DECK B STOP ON - OFF  
 S1105: DECK B REW ON - OFF  
 S1106: DECK B FF ON - OFF
- TIMER SWITCH ASS'Y**
- S1601: TIMER ON - OFF
- MECHANISM UNIT (B) PLAY - OFF - REC**
- S2303: ERASE PREVENT DETECTOR HOLE - NO HOLE
- The underlined indicates the switch position.

A

B

C

D

## 9. ELECTRICAL PARTS LIST

### NOTES:

- When ordering resistors, first convert resistance values into code form as shown in the following examples.
  - Ex. 1 When there are 2 effective digits (any digit apart from 0), such as 560 ohm and 47k ohm (tolerance is shown by J = 5%, and K = 10%).
 

560Ω	56 x 10 <sup>1</sup>	561	.....	RD4PS	561J
47kΩ	47 x 10 <sup>3</sup>	473	.....	RD4PS	473J
0.5Ω	0R5		.....	RN2H	0R5K
1Ω	010		.....	RS1P	010K
  - Ex. 2 When there are 3 effective digits (such as in high precision metal film resistors).
 

5.62kΩ	562 x 100	5621	.....	RN4SR	5621F
--------	-----------	------	-------	-------	-------
- The  $\Delta$  mark found on some component parts indicates the importance of the safety factor of the part. Therefore, when replacing, be sure to use parts of identical designation.
- For your Parts Stock Control, the fast moving items are indicated with the marks  $\star\star$  and  $\star$ .
  - $\star\star$  GENERALLY MOVES FASTER THAN  $\star$ .
  - This classification shall be adjusted by each distributor because it depends on model number, temperature, humidity, etc.

### Miscellaneous Parts

Mark	Part No.	Symbol & Description
	RWX-792	Main assembly Jack assembly Operation switch A assembly Operation switch B assembly VR assembly
	RWG-144	Pitch control assembly Sensor P assembly Sensor R/P assembly Timer SW assembly Transistor A assembly  Transistor B assembly Control assembly Power SW assembly Terminal assembly (A) Terminal assembly (B)
$\Delta$ $\star$	RTT-333	Power transformer (120V)
$\Delta$ $\star\star$	REK-073	Fuse (1.25A)
	RAW-194	Level meter assembly
	RWX-710	Music search assembly B

### Parts List of Control Assembly (RWG-144)

#### SEMICONDUCTORS

Mark	Part No.	Symbol & Description
$\star\star$	PD4029	IC801
$\star\star$	$\mu$ PD8243HC	IC802
$\star\star$	$\mu$ PD4069UBC	IC803, IC804
$\star\star$	2SC3246	Q801 - Q804, Q807 - Q809
$\star\star$	2SA881	Q806, Q811

Mark	Part No.	Symbol & Description
$\star\star$	2SC1740LN	Q814, Q816, Q824
$\star\star$	2SA933LN	Q805, Q810, Q812, Q813, Q815, Q817 - Q823
$\star$	1S2473	D803 - D812, D814 - D822
$\Delta$ $\star$	1B2C1-LC2	D801
$\Delta$ $\star$	1B2Z1-LC2	D802

#### CAPACITORS

Mark	Part No.	Symbol & Description
	RCH-054	C801
	CEA R47M 50	C804, C806
	CEA 010M 50	C818
	CEA 2R2M 50	C820
	CEA 100M 25	C803, C805
	CEA 100M 16	C815, C817
	CEA 330M 10	C808
	CKDYF 473Z 50	C810, C813, C814, C816, C819
	CKDYF 103Z 50	C807, C811
	CCDCH 330J 50	C809

#### RESISTORS

Note: When ordering resistors, convert the resistance value into code form, and then rewrite the part no. as before.

Mark	Part No.	Symbol & Description
	RS2LF $\square\square\square$ J	R807, R816
	RD1/4PM $\square\square\square$ J	R801 - R803, R808, R810 - R812, R824, R833, R843 - R845, R854
	RM4-103J	R809 Resistor array
	RM8-103J	R846 Resistor array
	RM9-103J	R842 Resistor array

Mark	Part No.	Symbol & Description
	RM10-103J	R836 Resistor array
	RM4-104J	R858 Resistor array
	RD1/6PM $\square\square\square$ J	Other resistors

#### OTHERS

Mark	Part No.	Symbol & Description
	RKP-806	Connector assembly 8P
	RKP-805	Connector assembly 9P

### Parts List of Power Switch Assembly

Mark	Part No.	Symbol & Description
$\Delta$ $\star\star$	RSA-060	S2101 Power switch
$\Delta$	RCG-008	C2101

### Parts List of Main Assembly (RWX-792)

#### SEMICONDUCTORS

Mark	Part No.	Symbol & Description
$\star\star$	IR2C30	IC301, IC401
$\star\star$	M5220L	IC701, IC703
$\star\star$	M5218L	IC702, IC704, IC706
$\star\star$	HA11226	IC705
$\star\star$	HD14066BP	IC707 - IC710
$\star\star$	2SC1740LN	Q101 - Q106, Q201 - Q206, Q301 - Q310, Q401 - Q410, Q704, Q705
$\star\star$	2SA933LN	Q702, Q703, Q706, Q707
$\star\star$	2SC2673	Q712
$\star\star$	2SD880	Q708
$\star$	1S2473	D301, D303 - D306, D401, D403 - D405, D705, D706, D708, D710 - D718
$\star$	1B2C1-LC2	D702, D704
$\star$	1B2Z1-LC2	D701, D703
$\star$	1M60	D302, D402
$\star$	RD5.6EB2	ZD701
$\star$	RD3.6EB2	ZD702
$\star$	RD4.3EB2	ZD704
$\star$	RD6.2EB2	ZD703

#### SWITCHES

Mark	Part No.	Symbol & Description
	RSG-152	S701 - S703 Push switch assembly

#### COILS

Mark	Part No.	Symbol & Description
	RTX-014	OSC block
	RTF-156	L101, L201 Trap Coil
	RTF-157	L304, L404 Trap Coil
	RTF-101	L701, L702 Line Coil
	RTF-158	L301, L401 MPX Filter

Mark	Part No.	Symbol & Description
	RTF-124	L302, L402 Coil (4.7mH)
	RTF-121	L303, L403 Coil (2.7mH)

#### CAPACITORS

Mark	Part No.	Symbol & Description
	CQSH 471J 50	C101, C201
	CEA R10M 50	C317, C417, C320, C420
	CEA R33M 50	C314, C414, C321, C421, C750
	CEA 010M 50	C107, C207, C306, C308, C312, C313, C322, C406, C408, C412, C413, C422, C732
	CEA 2R2M 50	C701
	CEA 4R7M 35	C324, C424, C722
	CEA R47M 50	C323, C423
	CEA 100M 16	C103, C110, C203, C210, C302, C309, C318, C402, C409, C418, C716, C721, C727, C729, C730, C731, C734

CEA 330M 10	C111, C211
CEA 470M 10	C105, C205, C304, C404, C704, C715
CEA 470M 16	C723, C724
CEA 471M 16	C733
CEA 221M 16	C711, C712, C717, C718

CEA 102M 16	C709, C710
RCH-054	C702
CEA 101M 6R3	C705
CQMA 472J 50	C315, C415
CQMA 103J 50	C106, C206, C305, C326, C405, C426
CQMA 273J 50	C108, C109, C208, C209, C307, C407
CQMA 223J 50	C332, C432
CQMA 153J 50	C316, C319, C328, C416, C419, C428

CQMA 333J 50	C331, C431
CQMA 822J 50	C329, C330, C429, C430
CQMA 682J 50	C327, C427
CQMA 222J 50	C112, C212
CQMA 102K 50	C310, C311, C410, C411
CCPSL 101J 50	C104, C204, C303, C403
CCDSL 471K 50	C325, C425
CCDSL 101K 500	C333, C433
CKDYF 473Z 50	C728
CKDYF 103Z 50	C706, C713, C714, C719, C720, C725, C726

CQSH 681J 50	C301, C401
CQSH 221J 50	C102, C202

#### RESISTORS

Note: When ordering, into code form

Mark	Part No.
$\star$	RCP-194
$\star$	RCP-150
$\star$	RCP-195
$\star$	RCP-154
$\star$	RCP-199
$\star$	RCP-193
$\star$	RCP-149
	RD1/2PMF $\square\square$
	RD1/4PM $\square\square$
	RD1/6PM $\square\square$

#### OTHERS

Mark	Part No.
	RK B-020
	RK P-806
	RK P-803
	RK P-814
	RK P-747
	RK P-748
	RK P-749
	RSR-035

### Parts List of Jack A

Note: When ordering, into code form

Mark	Part No.
$\star\star$	M5218L
$\star\star$	BA328
	CKDYB 102K
	CEA 100M 16
	CEA 101M 10
	CKDYF 473Z
	RD1/6PM $\square\square$
	RKM-081
	RKM-080
	RKP-750
	RKP-751

## RESISTORS

Note: When ordering resistors, convert the resistance value into code form, and then rewrite the part no. as before.

Mark	Part No.	Symbol & Description
★	RCP-194	VR101, VR201, VR301, VR401 Semi-fixed (15k-B)
★	RCP-150	VR102, VR202, VR302, VR303, VR402, VR403 Semi-fixed (22k-B)
★	RCP-195	Semi-fixed (22k-B)
★	RCP-154	VR304, VR404 Semi-fixed (100k-B)
★	RCP-199	Semi-fixed (100k-B)
★	RCP-193	VR701 Semi-fixed (10k-B)
★	RCP-149	Semi-fixed (10k-B)
	RD1/2PMF □□□J	R703, R709, R710
	RD1/4PM □□□J	R103, R106, R203, R206, R302, R305, R318, R327, R402, R405, R418, R427, R713, R733 – R735
	RD1/6PM □□□J	Other Resistors

## OTHERS

Mark	Part No.	Symbol & Description
	RKB-020	4P Pinjack
	RKP-806	Connector assembly 12P
	RKP-803	Connector assembly 13P
	RKP-814	Connector assembly 2P
	RKP-747	Board in Connector 3P
	RKP-748	Board in Connector 3P
	RKP-749	Board in Connector 3P
	RSR-035	RY701 Relay

## Parts List of Jack Assembly (RWX-793)

Note: When ordering resistors, convert the resistance value into code fom, and then rewrite the part no. as before.

Mark	Part No.	Symbol & Description
★★	M5218L	IC502
★★	BA328	IC501
	CKDYB 102K 50	C501, C601
	CEA 100M 16	C502 – C504, C602 – C604
	CEA 101M 10	C505, C506, C605, C606
	DKDYF 473Z 50	C507
	RD1/6PM □□□J	R501 – R508, R601 – R608
	RKN-081	Headphone jack
	RKN-080	MIC jack
	RKP-750	Connector assembly 5P
	RKP-751	Connector assembly 3P

## Parts List of Operation Switch A Assembly (RWS-193)

Mark	Part No.	Symbol & Description
★	BG5524S	LED1001, LED1002
★	PR5524S	LED1003
★★	RSG-143	S1001 – S1004 Push switch
★★	RSG-063	S1006 Operation switch
★★	RSG-150	S1005, S1007, S1008 Push switch
★★	RSG-153	S1009 Push switch
	RD1/6PM201J	R1001
	RKP-752	Connector assembly 6P
	RKP-809	Connector assembly 4P
	RKP-754	Connector assembly 4P
	RKP-812	Connector assembly 3P

## Parts List of Operation Switch B Assembly

Mark	Part No.	Symbol & Description
★★	RSG-143	S1101 – S1106 Push switch
	RKP-807	Connector assembly 7P

## Parts List of VR Assembly

Mark	Part No.	Symbol & Description
★	RCV-109	VR1201 Variable (20k-A)
	RKP-760	Connector assembly 3P
	RKP-761	Connector assembly 3P

## Parts List of Pitch Control Assembly

Mark	Part No.	Symbol & Description
★	RCS-026	VR1301 Variable (1k-B)

## Parts List of Sensor P Assembly

Mark	Part No.	Symbol & Description
★	GP-411B	RTR1401 Photo interrupter
	RKP-811	Connector assembly 3P

## Parts List of Sensor R/P Assembly

Mark	Part No.	Symbol & Description
★	GP-411B	RTR1501
	RKP-810	Connector assembly 3P

## Parts List of Timer Switch Assembly

Mark	Part No.	Symbol & Description
★★	RSH-064	S1601 Slide switch
	RKP-813	Connector assembly 3P

## Parts List of Transistor A Assembly

Mark	Part No.	Symbol & Description
★★	2SD1265	Q1701

## Parts List of Transistor B Assembly

Mark	Part No.	Symbol & Description
★★	2SD1265	Q1801

## Parts List of Terminal Assembly (A)

Mark	Part No.	Symbol & Description
★★	2SC1740LN	Q01
★	1SR35-100A	D01 – D04
	RD1/4PM103J	R01
	RKP-717	Board in connector 4P

## Parts List of Terminal Assembly (B)

Note: When ordering resistors, convert the resistance value into code form, and then rewrite the part no. as before.

Mark	Part No.	Symbol & Description
★★	2SC1740LN	Q11
★	1SR35-100A	D11 – D13
	RD1/4PM □□□J	R11, R12
	RKP-717	Board in connector 4P

# 10. ADJUSTMENTS

## 10.1 MECHANICAL ADJUSTMENTS

- Before commencing any mechanical adjustments, clean the capstan, pinch roller, idler, and belts with a cloth dipped in a little alcohol.
- Unless specifically indicated, the following adjustments refer to both deck A and B.

### 1. Pinch Roller Pressure Check • Use tension gauge (GGK-047)

Mode	Specifications rating	Conditions
PLAY	230g ~ 350g	Let the pinch roller slowly approach the capstan, and read the tension gauge value when the pinch roller commences to rotate.

- Replace the pinch roller pressure spring (RBH-890)

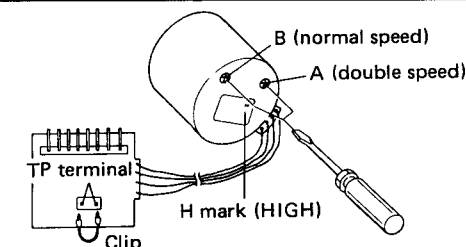
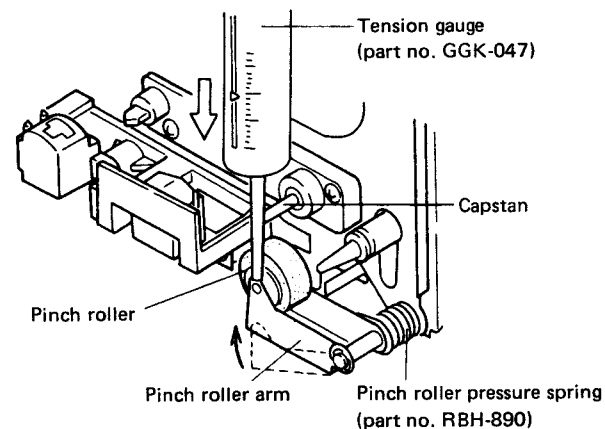

### 4. FF Solenoid Adjustment

Mode	Adjustment location	Specifications
FF	FF solenoid position (loosen screws (1) to permit movement).	The square hole in the reel base full ass'y must make contact with the boss of the drive arm full ass'y.

### 5. REW Solenoid Adjustment

Mode	Adjustment location	Specifications
REW	REW solenoid position (loosen screws (2) to permit movement).	The square hole in the reel base full ass'y must make contact with the boss of the drive arm full ass'y.

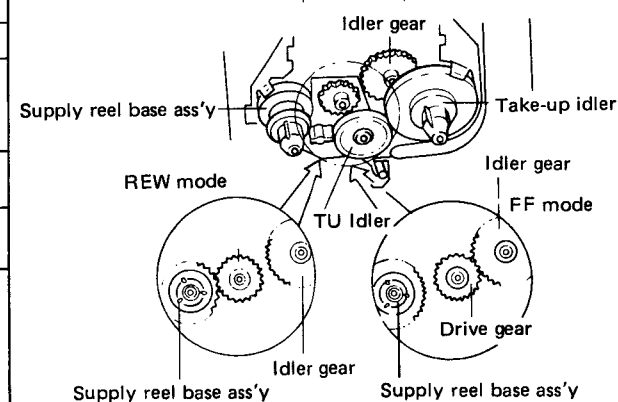
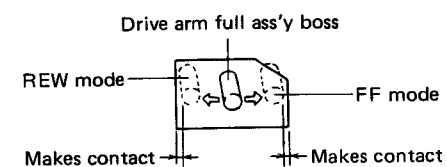
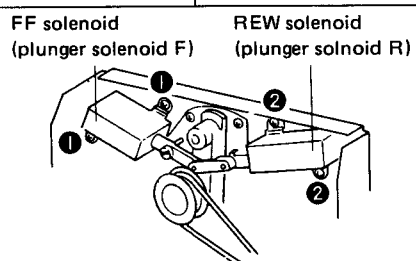

### 2. Reel Base Torque Check • Use torque meter (GGK-056)

Mode	Take-up reel base torque ratings	Supply reel base torque ratings
PLAY	35g-cm ~ 55g-cm	*2g-cm ~ 5g-cm
FF	85g-cm ~ 125g-cm	*2g-cm ~ 5g-cm
REW	*2g-cm ~ 5g-cm	85g-cm ~ 125g-cm

\* Back-tension torque

- If the specified torque ratings are not satisfied, replace the supply reel base ass'y (RXB-714) take-up reel base ass'y (RXB-715) drive arm full ass'y (RXB-376).

### 3. Tape Speed Adjustment • Adjust at beginning of tape

Mode	Test tape	Adjustment location	Specifications rating (playback frequency)
Double speed PLAY	STD-301 (3kHz)		6010Hz ± 10Hz
Normal speed PLAY	STD-301 (3kHz)		3010Hz ± 5Hz

1. Short the TP terminal, and adjust from double speed.
2. Open the TP terminal, and adjust at normal speed.
3. The deck B tape speed must not deviate from the deck A tape speed by more than ± 10Hz at double speed, nor by more than ± 5Hz at normal speed.

### 6. Music Search Adjustment (Deck A)

Mode	Adjustment location	Specification
MS	See diagram below	Using a screwdriver inserted into the notch (A) in lever (B), adjust dimension G indicated in the following diagram to 7.8 ~ 8.1 mm.

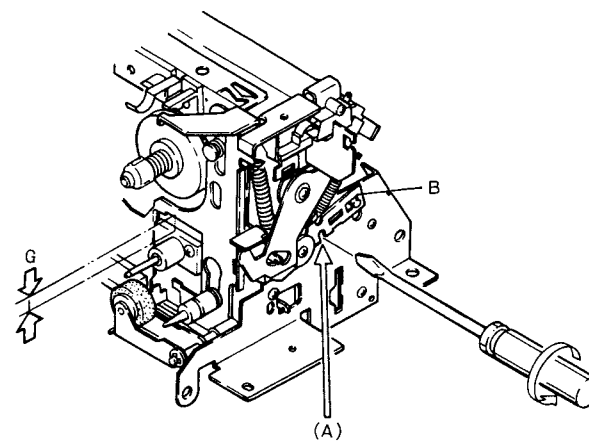

### 8. Chrome Detector Adjustment (Deck A)

Adjustment location	Adjustment method
Chrome detector lever	Adjust S2201 to be switched on when the STD-603 test tape is loaded, and S2201 to be switched off when the STD-608A test tape is loaded.

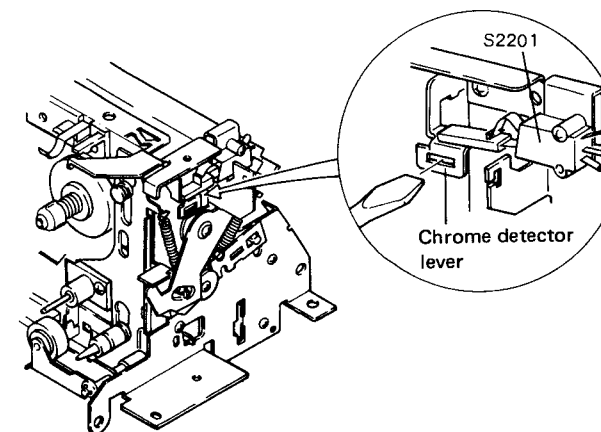

### 7. Eject Adjustment

Adjustment location	Adjustment method
Chrome detector lever	Adjust gap C to 0 ~ 0.5mm when the pocket is closed without a cassette half loaded.
Check point	Make sure that a gap exists between cassette halves and the detector lever.

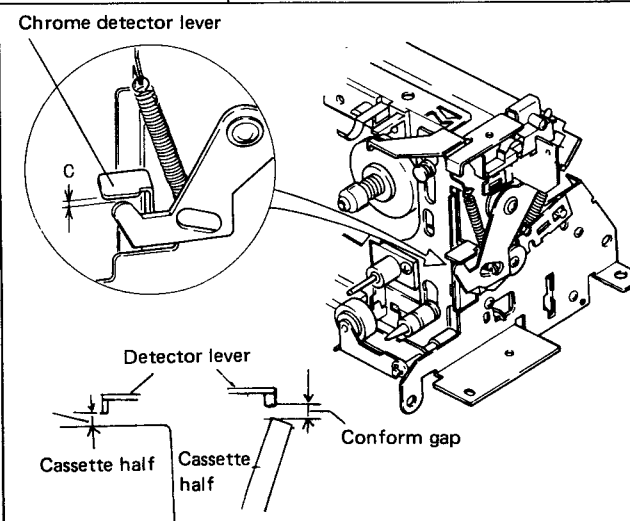

### 9. Chrome Detector Adjustment (Deck B)

Adjustment location	Adjustment method
Chrome detector lever	Adjust S2301 to be switched on when the STD-603 test tape is loaded, and S2301 to be switched off when the STD-608A test tape is loaded.
Metal detector lever	Adjust S2302 to be switched on when the STD-604 test tape is loaded, and S2302 to be switched off when the STD-608A test tape is loaded.

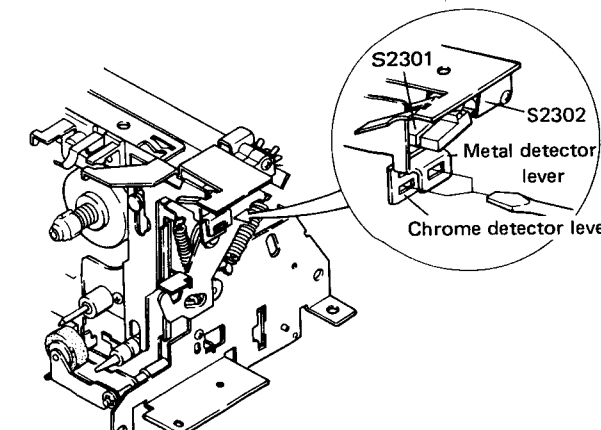

10.2 ELECTRICAL ADJUSTMENTS

Before commencing any electrical adjustments, make sure the following checked/completed.

- All mechanical adjustments must have been completed.
- The heads must be clean and demagnetized.
- Connect a 50kΩ (47kΩ ~ 52kΩ) dummy resistance to the OUTPUT terminal with 0dB = 1V during level measurements.
- Use the specified tapes for each adjustment. Although test tapes have both A and B sides, only use side A where the label is attached.  
STD-331B: Playback adjustment  
STD-608A: NORMAL blank tape  
STD-603: CrO2 blank tape  
STD-604: METAL blank tape
- Prepare the following measuring equipment. AC millivoltmeter, audio generator, attenuator, oscilloscope.
- Adjust both left and right channels unless otherwise specified.
- And unless indicated otherwise, leave the DOLBY NR switch in the OFF position.

- Let the set warm up for at least a few minutes before commencing adjustments. And before commencing the record/playback frequency response adjustment, let the set "age" for three to five minutes.
- Always adjust the set in the given adjustments order. If the order is changed, proper adjustment will not be possible, and this may result in loss of performance.

Adjustment Procedure

Deck A

- Head azimuth adjustment
- Playback equalizer adjustment
- Playback level adjustment

Deck B

- Dolby NR level adjustment
- Head azimuth adjustment
- Playback equalizer adjustment
- Playback level adjustment
- Level meter display check
- Recording/Playback frequency response
- Recording level adjustment

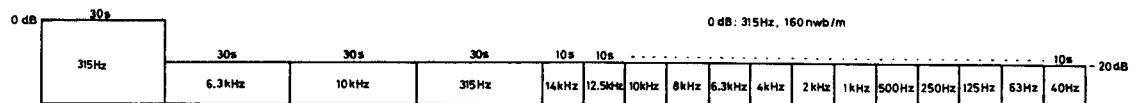

Fig. 10-1 Test tape STD-331B

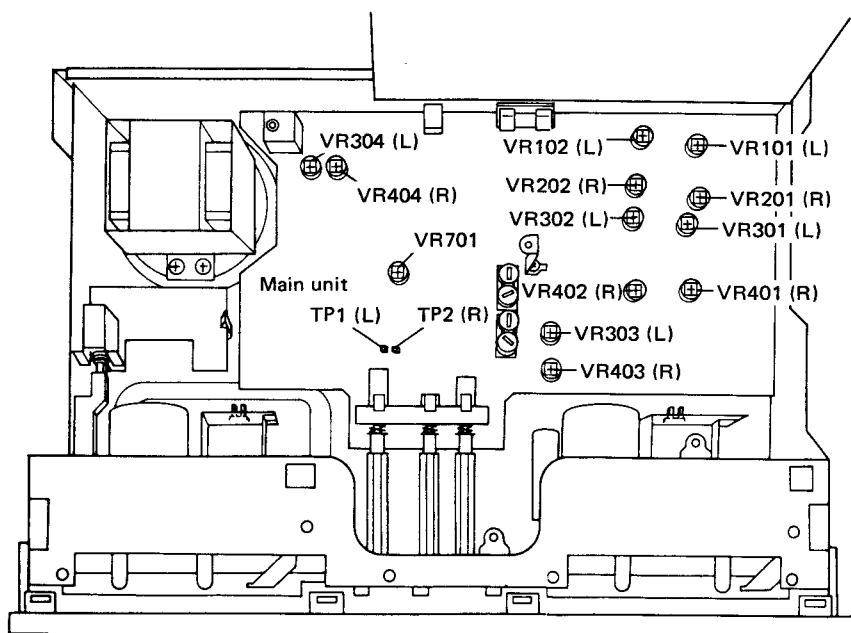

Fig. 10-2 Adjustment locations

- Deck A**
  - Playback equalizer adjustment
    - VR101 (L)
    - VR201 (R)
  - Playback level adjustment
    - VR102 (L)
    - VR202 (R)
- Deck B**
  - Dolby NR adjustment
    - VR701
  - Playback equalizer adjustment
    - VR301 (L)
    - VR401 (R)
  - Playback level adjustment
    - VR302 (L)
    - VR402 (R)
  - Recording/playback frequency response adjustment
    - VR304 (L)
    - VR404 (R)
  - Recording level adjustment
    - VR303 (L)
    - VR403 (R)

• DECK A ADJUSTMENT (with auto tape selector function)						
<b>1. Head Azimuth Adjustment</b> • Set VR102 and VR202 (playback level adjustment) to MAX positions (turn fully clockwise)						
Tape selector	Mode	Input signal/test tape	Adjustment location	Measuring location	Adjustment value	Remarks
NORM	PLAY	Play 10kHz -20dB portion of STD-331B test tape.	Head azimuth adjustment screw. (Fig. 10-3)	Left and right playback terminals.	Maximum playback signal level.	Apply "screw-lock" after completing adjustment.
<b>2. Playback Equalizer Adjustment</b> • Set VR101 and VR202 (playback level adjustment) to the physical center positions.						
Tape selector	Mode	Input signal/test tape	Adjustment location	Measuring location	Adjustment value	Remarks
NORM	PLAY	Play the 315Hz -20dB and 6.3kHz -20dB portions of the STD-331B test tape.	VR101 (L) VR201 (R)	Left and right playback terminals.		The playback level at 6.3kHz must be within -0.5 ± 0.5dB of the level at 315Hz (see playback frequency response in Fig. 10-4.)
<b>3. Playback Level Adjustment</b> • Adjust precisely since this adjustment sets the playback Dolby level.						
Tape selector	Mode	Input signal/test tape	Adjustment location	Measuring location	Adjustment value	Remarks
NORM	PLAY	Play the 315Hz 0dB portion of the STD-331B test tape.	VR102 (L) VR202 (R)	TP1 (L) TP2 (R)	-5.2dBv (550mV)	
• DECK B ADJUSTMENT (with auto tape selector function)						
<b>1. Dolby NR Level Adjustment</b>						
Tape selector	Mode	Input signal/test tape	Adjustment location	Measuring location	Adjustment value	Remarks
NORM	REC	Apply a 2kHz -10dBv (316mV) signal to the recording terminals.	1 Recording level control	TP1 (L) TP2 (R)	-2.2dBv (775mV)	
			2 DOLBY NR switch . . . . . ON			
NORM	REC	Apply a 2kHz -30dBv (31.6mV) signal to the recording terminals.	3 VR701	TP1 (L) TP2 (R)	-17.9dBv ± 0.2dB	
<b>2. Head Azimuth Adjustment</b> • Set VR302 and VR402 (playback level adjustment) to MAX positions (turn fully clockwise)						
Tape selector	Mode	Input signal/test tape	Adjustment location	Measuring location	Adjustment value	Remarks
NORM	PLAY	Play 10kHz -20dB portion of STD-331B test tape.	Head azimuth adjustment screw. (Fig. 10-3)	Left and right playback terminals. L · R	Maximum playback signal level.	Apply "screw-lock" after completing adjustment.
<b>3. Playback Equalizer Adjustment</b> • Set VR302 and VR402 (playback level adjustment) to the physical center positions.						
Tape selector	Mode	Input signal/test tape	Adjustment location	Measuring location	Adjustment value	Remarks
NORM	PLAY	Play the 315Hz -20dB and 6.3kHz -20dB portions of the STD-331B test tape.	VR301 (L) VR401 (R)	Left and right playback terminals L · R		The playback level at 6.3kHz must be within -0.5 ± 0.5dB of the level at 315Hz (see playback frequency response in Fig. 10-4.)
<b>4. Playback Level Adjustment</b> • Adjust precisely since this adjustment sets the playback Dolby level.						
Tape selector	Mode	Input signal/test tape	Adjustment location	Measuring location	Adjustment value	Remarks
NORM	PLAY	Play the 315Hz 0dB portion of the STD-331B test tape.	VR302 (L) VR402 (R)	TP1 (L) TP2 (R)	-5.2dBv (550mV)	
<b>5. Level Meter Display Check</b>						
Tape selector	Mode	Input signal/test tape	Adjustment location	Measuring location	Adjustment value	Remarks
NORM	REC	Apply a 315Hz -10dBv (316mV) signal to the recording terminals.	1 Recording level control	Level meter display	0dB	
			2	TP1 (L) TP2 (R)	-5.2dBv ± 0.5dB	
<b>6. Recording/Playback Frequency Response Adjustment</b>						
Tape selector	Mode	Input signal/test tape	Adjustment location	Measuring location	Adjustment value	Remarks
NORM	REC	Apply a 315Hz -30dBv (31.6mV) signal to the recording terminals.	1 Recording level control	TP1 (L) TP2 (R)	-25.2dBv (55mV)	
NORM	REC/PLAY	Record 315Hz and 6.3kHz signals on the STD-608A test tape, and then play back signals.	2 VR304 (L) VR404 (R)	TP1 (L) TP2 (R)		Repeat the recording and playback processes and adjust accordingly until the 6.3kHz playback level is within +1.0 ± 0.5dB of the 315Hz level.
• Change the test tape and the DOLBY NR switch position and check that the frequency response zone indicated in Fig. 10-5 is satisfied. If the response curves are unsatisfactory, the 6.3kHz playback level can be readjusted to within +1.0 ± 0.5dB of the 315Hz level.						

7. Recording Level Adjustment							
Tape selector	Mode	Input signal/test tape		Adjustment location	Measuring location	Adjustment value	Remarks
NORM	REC	Apply a 315 Hz -10 dBv (315 mV) signal to the recording terminals.	1	Recording level control	TP1 (L) TP2 (R)	-5.2 dBv (550 mV)	
NORM	REC/PLAY	Record the 315 Hz signal onto the STD-608A test tape, and then play the signal back.	2	VR303 (L) VR403 (R)	TP1 (L) TP2 (R)		Repeat the recording the playback processes, and adjust accordingly until a playback level of -5.2 dBv (550 mV) is obtained.
CrO <sub>2</sub>	REC/PLAY	Record the 315 Hz signal onto the STD-603 test tape, and then play the signal back.	3		TP1 (L) TP2 (R)		Check that the 315 Hz playback level is - 5.2 dBv ± 1.5 dB.
METAL	REC/PLAY	Record the 315 Hz signal onto the STD-604 test tape, and then play the signal back.	4		TP1 (L) TP2 (R)		Check that the 315 Hz playback level is - 5.2 dBv ± 1.5 dB.

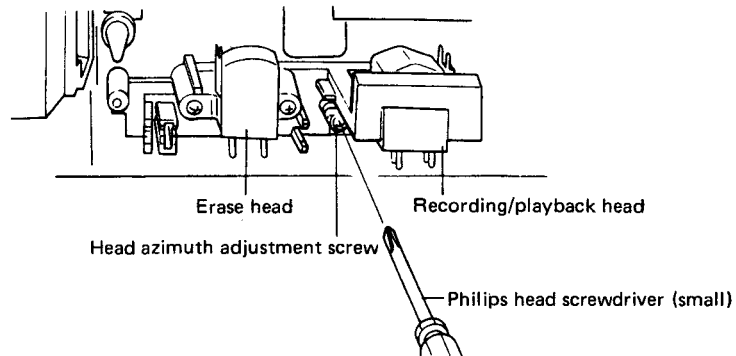

Fig. 10-3 Head azimuth adjustment

The CT-1040W features an auto tape selector mechanism.

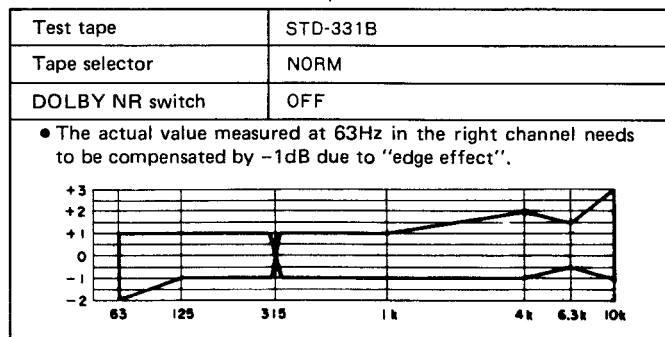

Fig. 10-4 Playback frequency response

The CT-1040W features an auto tape selector mechanism.

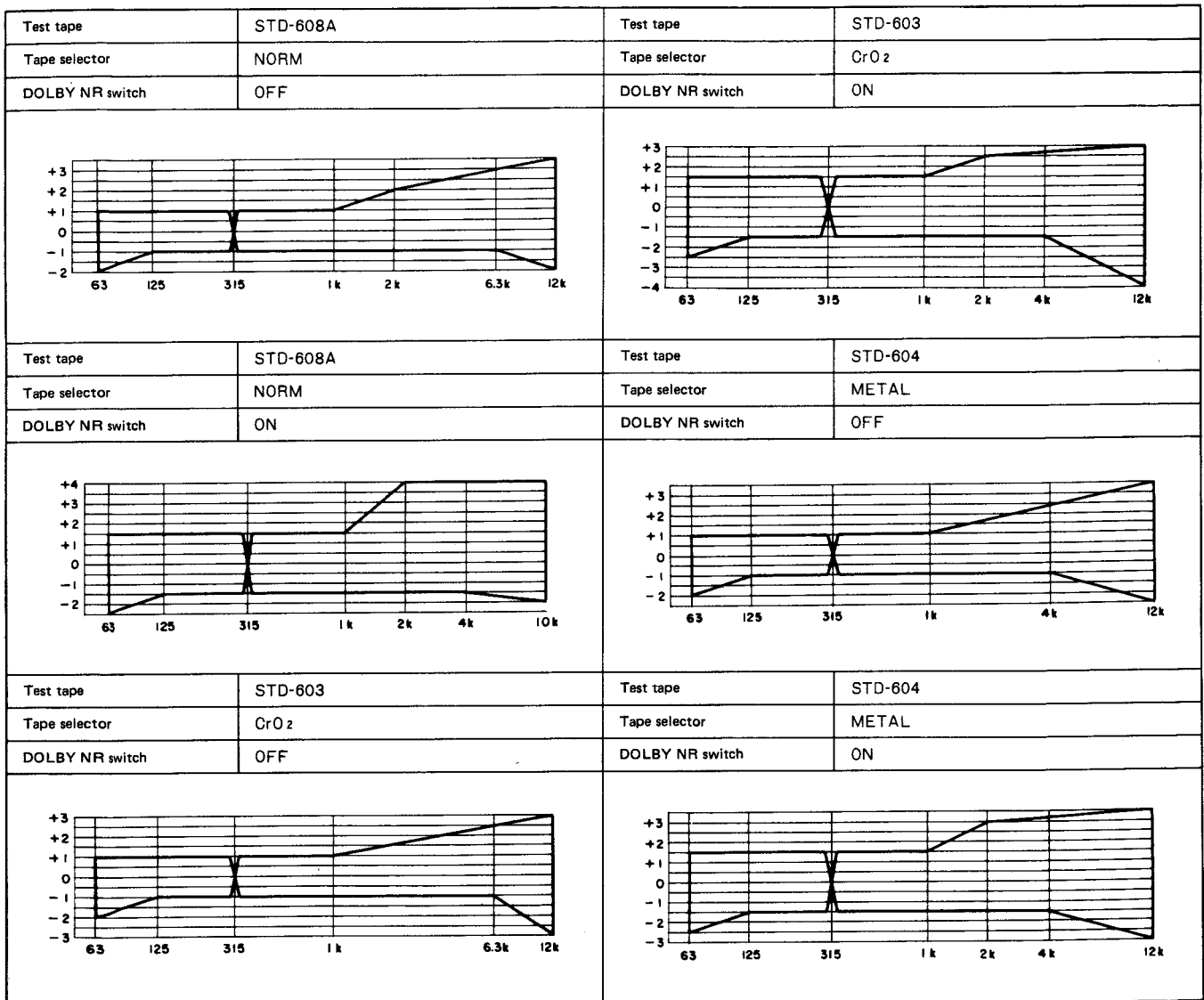

Fig. 10-5 Overall frequency

The CT-1040W features an auto tape selector mechanism.

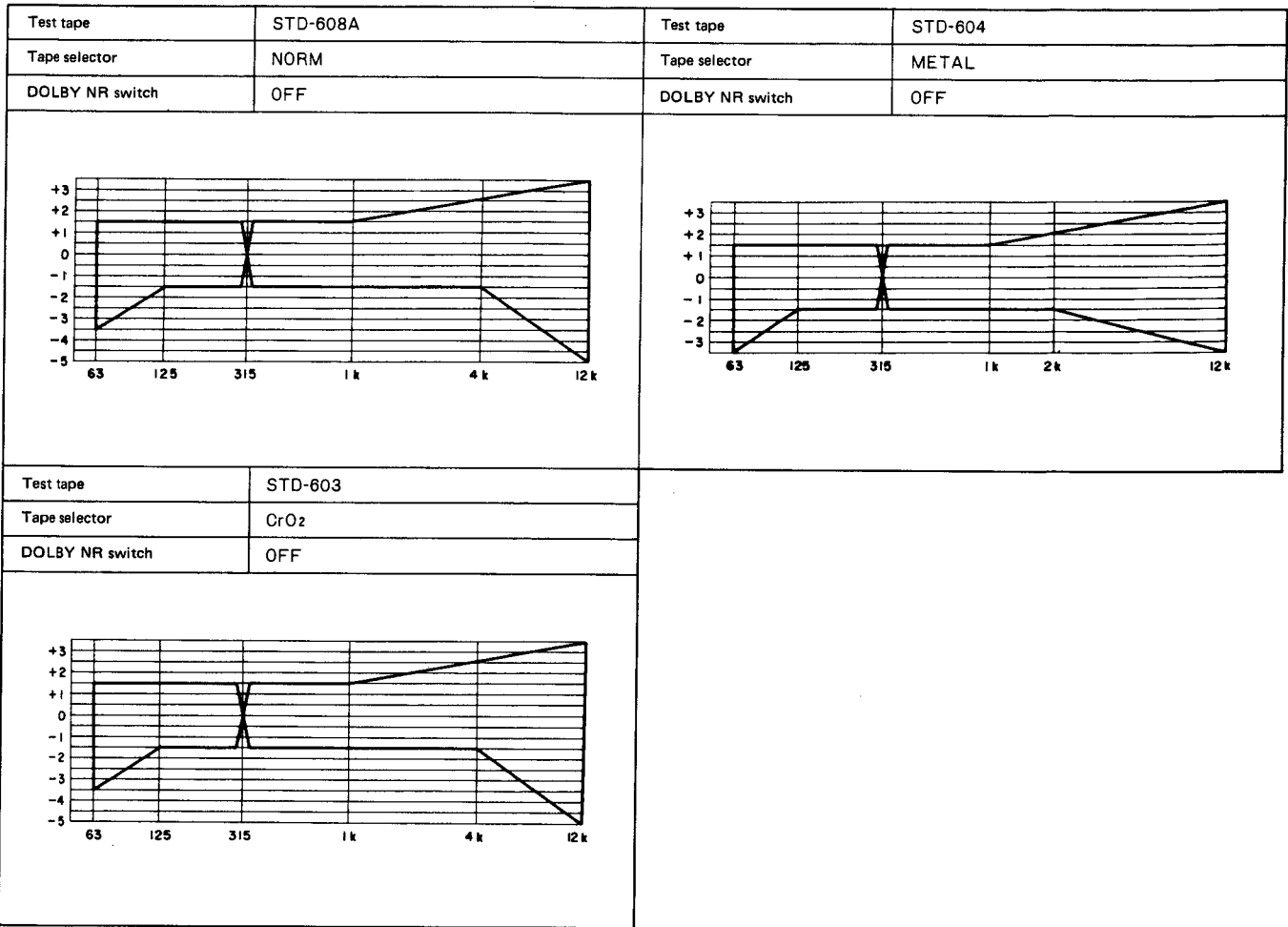

Fig. 10-6 Copy frequency response

# 10. RÉGLAGE

## 10.1 RÉGLAGES MÉCANIQUES

- Avant de procéder aux réglages mécaniques, nettoyer le cabestan, le galet presseur, la poulie et les courroies à l'aide d'un chiffon imbibé d'un peu d'alcool.
- Sauf spécification contraire, les réglages ci-dessous s'appliquent aux deux platines A et B.

**1. Vérification du galet presseur**  
 • Utiliser une jauge de tension (GGK-047)

Mode	Valeur nominale	Procédé
Reproduction (PLAY)	230g ~ 350g	Approcher lentement le galet presseur vers le cabestan, et lire la valeur indiquée par la jauge de pression lorsque le galet presseur commence à tourner.

• Remplacement du ressort du galet presseur (RBH-890)

**2. Vérification du couple à la base du pignon de la bobine.**  
 • Utiliser un appareil de mesure de couple (GGK-056)

Mode	Couple à la base du pignon de bobine d'enroulement	Couple à la base du pignon de bobine débitrice
PLAY	35g-cm ~ 55g-cm	*2g-cm ~ 5g-cm
FF	85g-cm ~ 125g-cm	*2g-cm ~ 5g-cm
REW	*2g-cm ~ 5g-cm	85g-cm ~ 125g-cm

\* Couple de contre-tension.

■ Si les couples ne sont pas conformes aux valeurs nominales, remplacer l'ensemble base pignon de bobine débitrice (RXB-714), l'ensemble base pignon de bobine d'enroulement (RXB-715), l'ensemble arbre d'entraînement (RXB-376)

**3. Réglage de la vitesse de la bande.**  
 • Procéder au réglage au début de la bande.

Mode	Bade d'essai	Emplacement du réglage	Valeurs nominales (fréquence de reproduction)
Vitesse double Reproduction (PLAY)	STD-301 (3kHz)		6010Hz±10Hz
Vitesse normale Reproduction (PLAY)	STD-301 (3kHz)		3010Hz±5Hz

1. Mettre la borne TP en court-circuit et régler la vitesse double.
2. Ouvrir la borne TP et régler la vitesse normale.
3. La vitesse de la platine B ne doit pas s'écarter de la vitesse de la platine A de plus de ±10Hz à la vitesse double, et de plus de ±5Hz à la vitesse normale.

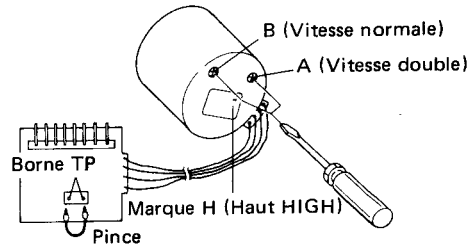

**4. Réglage du solénoïde de l'avance rapide (FF)**

Mode	Emplacement du réglage	Spécifications
Avance rapide (FF)	Solénoïde de l'avance rapide (FF) (déserrer les vis (1) pour permettre le dégagement)	L'orifice carré se trouvant dans l'ensemble base pignon de bobine doit être en contact avec le moyeu de l'ensemble bras d'entraînement.

**5. Réglage du solénoïde du réembobinage (REW)**

Réembobinage	Solénoïde du réembobinage (REW) (déserrer les vis (2) pour permettre le mouvement)	L'orifice carré se trouvant dans l'ensemble base pignon de bobine doit être en contact avec le moyeu de l'ensemble bras d'entraînement.
--------------	--	---

Solénoïde de l'avance rapide (FF) (solénoïde à noyau mobile F)      Solénoïde du réembobinage (REW) (solénoïde à noyau mobile R)

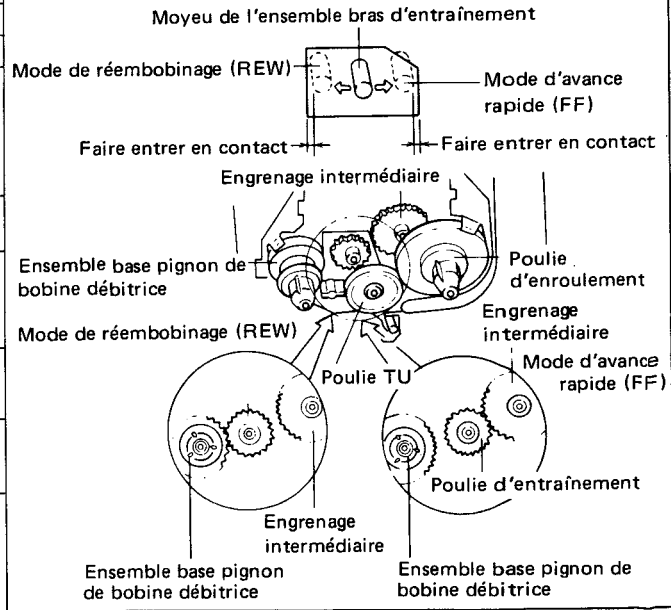
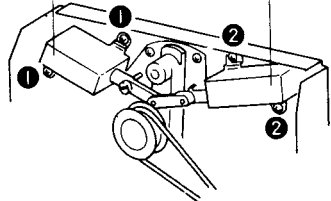

**6. Réglage de recherche musique (platine A)**

Mode	Emplacement du réglage	Spécifications
Recherche musique (MS)	Voir schéma ci-dessous	A l'aide d'un tournevis introduit dans l'encoche (A) du levier (B), régler l'écartement G indiqué sur le schéma entre 7,8 et 8,1mm.

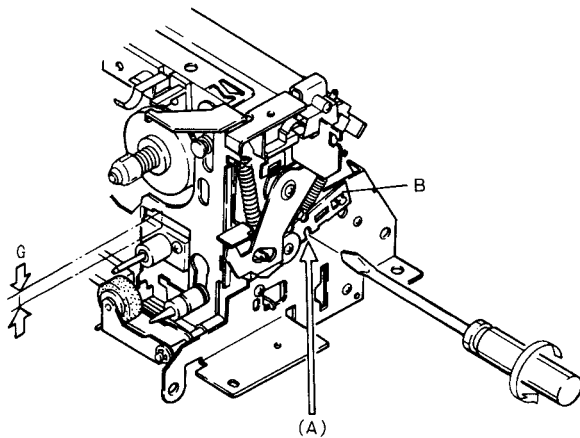

**8. Réglage du détecteur de bande au chrome (platine A)**

Emplacement du réglage	Méthode de réglage
Levier du détecteur de bande au chrome	Régler S2201 qui doit être allumé lorsque la bande d'essai STD-603 est chargée, et le S2201 qui doit être arrêté lorsque la bande d'essai STD-608A est chargée.

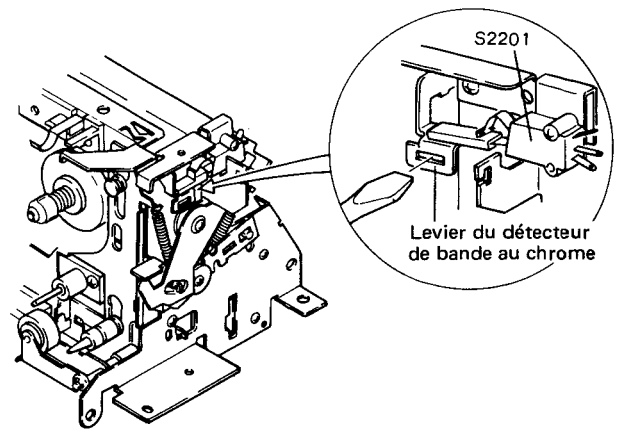

**7. Réglage de l'éjection**

Emplacement du réglage	Méthode de réglage
Levier du détecteur de bande au chrome	Régler l'écartement C entre 0 et 0,5mm lorsque le logement est fermé en l'absence de cassette.
Point de vérification	S'assurer qu'il y a bien un espace entre la cassette entre le levier de détection.

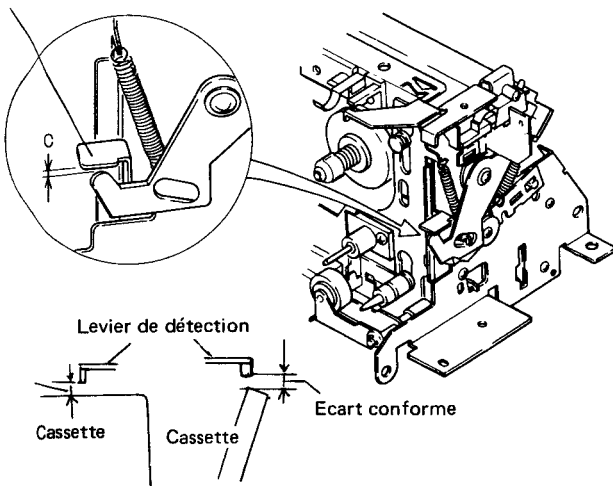

**9. Réglage du détecteur de bande au chrome (platine B)**

Emplacement du réglage	Méthode de réglage
Levier du détecteur de bande au chrome	Régler le S2301 qui doit être allumé lorsque la bande d'essai STD-603 est chargée, et le S2301 qui doit être arrêté lorsque la bande d'essai STD-608A est chargée.
Levier de détecteur de bande "métal"	Régler le S2302 qui doit être allumé lorsque la bande d'essai STD-604 est chargée, et le S2302 qui doit être arrêté lorsque la bande d'essai STD-608A est chargée.

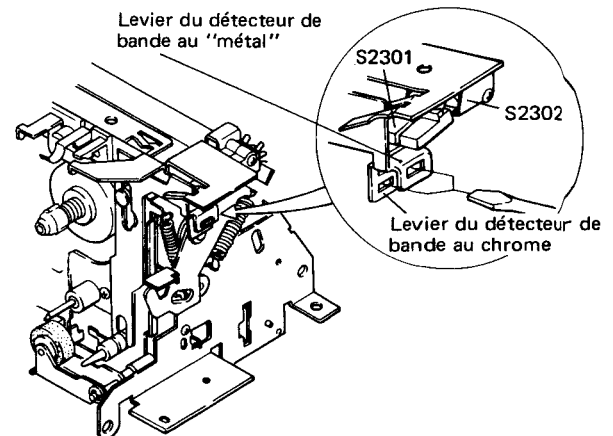

## 10.2 RÉGLAGES ÉLECTRIQUES

■ Avant de commencer à procéder aux réglages électriques, bien effectuer les vérifications suivantes.

1. Tous les réglages mécaniques ont été effectués.
2. Les têtes doivent être propres et démagnétisées.
3. Brancher une résistance fictive de 50 kohms (47 ~ 52 kohms) sur la borne de sortie (OUTPUT) en se basant sur 0dB = 1V pendant les mesures de niveau.
4. Utiliser les bandes spécifiées pour chaque réglage. Bien que les bandes d'essai aient à la fois une face A et une face B, n'utiliser que la face A sur laquelle est attachée l'étiquette.  
 STD-331B : Réglage de la reproduction.  
 STD-608A : Bande vierge ordinaire (NORMAL)  
 STD-603 : Bande vierge à l'oxyde de chrome (CrO<sub>2</sub>)  
 STD-604 : Bande vierge au métal (METAL)
5. Préparer les équipements de mesure ci-après : millivoltmètre CA, générateur audio, atténuateur, oscilloscope.
6. Régler à la fois le canal gauche et le canal droit, sauf spécification contraire.
7. Sauf spécification contraire, laisser le commutateur de réduction de bruit DOLBY en position arrêt (OFF).

8. Laisser l'appareil chauffer pendant au moins quelques minutes avant de commencer les réglages. Avant de commencer le réglage de la réponse en fréquences enregistrement/reproduction, laisser l'appareil fonctionner de trois à cinq minutes.
9. Toujours procéder aux réglages dans l'ordre indiqué. Si cet ordre est modifié, il ne sera plus possible d'effectuer des réglages correctement, et cela pourrait entraîner une dégradation des performances.

### Procédure de réglage

#### Platine A

1. Réglage de l'azimutage de la tête.
2. Réglage de l'égalisateur de reproduction.
3. Réglage du niveau de reproduction.

#### Platine B

1. Réglage du niveau du système de réduction de bruit DOLBY.
2. Réglage de l'azimutage de la tête.
3. Réglage de l'égalisateur de reproduction.
4. Réglage du niveau de reproduction.
5. Vérification de l'affichage indicateur de niveau.
6. Réponse en fréquences enregistrement/reproduction.
7. Réglage du niveau d'enregistrement.

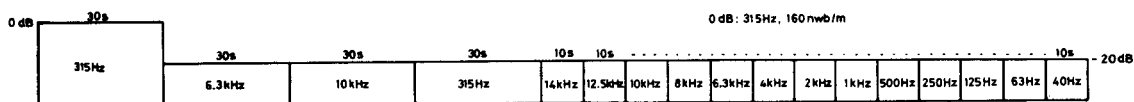
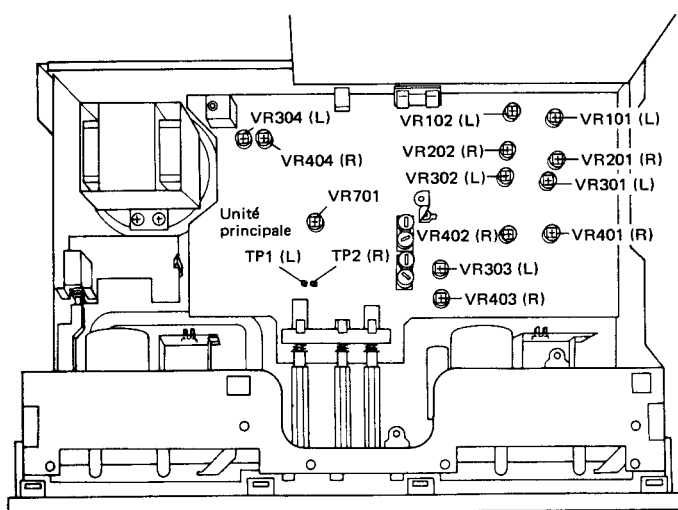

Fig. 10-1 Bande d'essai STD-331B



#### • Platine A

Réglage de l'égalisateur de reproduction  
 VR101 gauche (L)  
 VR201 droit (R)

Réglage du niveau de reproduction  
 VR102 gauche (L)  
 VR202 droit (R)

#### • Platine B

Réglage du réducteur de bruit DOLBY  
 VR701

Réglage de l'égalisateur de reproduction  
 VR301 gauche (L)  
 VR401 droit (R)

Réglage du niveau de reproduction  
 VR302 gauche (L)  
 VR402 droit (R)

Réglage de la réponse en fréquences d'enregistrement-reproduction  
 VR304 gauche (L)  
 VR404 droit (R)

Réglage du niveau d'enregistrement  
 VR303 gauche (L)  
 VR403 droit (R)

Fig. 10-2 Emplacements des réglages

● RÉGLAGE DE LA PLATINE A (Avec sélecteur automatique de bande)							
<b>1. Réglage de l'azimutage de la tête</b> ● Placer le VR102 et le VR202 (Réglage du niveau de reproduction) sur la position maximale MAX (tourner complètement dans le sens des aiguilles d'une montre).							
Sélecteur de bande	Mode	Signal d'entrée/bande d'essai	Emplacement du réglage	Emplacement de mesure	Valeur de réglage	Remarques	
Normal (NORM)	Reproduction (PLAY)	Reproduire la portion 10kHz -20dB de la bande d'essai STD-331B.	Vis de réglage de l'azimutage de la tête. (Fig. 10-3)	Bornes de reproduction droite et gauche.	Niveau de signal de reproduction maximal.	Mettre en place "l'arrêt de vis" après avoir terminé ce réglage.	
<b>2. Réglage de l'égalisateur de reproduction</b> ● Placer le VR201 et le VR202 (Réglage du niveau de reproduction) sur la position centrale.							
Sélecteur de bande	Mode	Signal d'entrée/bande d'essai	Emplacement du réglage	Emplacement de mesure	Valeur de réglage	Remarques	
Normal (NORM)	Reproduction	Reproduire les portions 315Hz -20dB et 6,3kHz -20dB de la bande d'essai.	VR101 gauche (L) VR201 droit (R)	Borne de reproduction droite et gauche.	Le niveau de reproduction à 6,3kHz doit être compris entre -0,5 ±0,5dB du niveau à 315Hz (Voir la réponse en fréquences de reproduction sur la Fig. 10-4).		
<b>3. Réglage du niveau de reproduction</b> ● Procéder à cet réglage avec précision car celui-ci détermine le niveau de reproduction du DOLBY.							
Sélecteur de bande	Mode	Signal d'entrée/bande d'essai	Emplacement du réglage	Emplacement de mesure	Valeur de réglage	Remarques	
Normal (NORM)	Reproduction (PLAY)	Reproduire la portion 315Hz 0dB de la bande d'essai STD-331B.	VR102 gauche (L) VR202 droit (R)	TP1 gauche (L) TP2 droit (R)	-5,2dB (550mV)		
● RÉGLAGE DE LA PLATINE B (Avec sélecteur automatique de bande)							
<b>1. Réglage du niveau du réducteur de bruit DOLBY</b>							
Sélecteur de bande	Mode	Signal d'entrée/bande d'essai	Emplacement du réglage	Emplacement de mesure	Valeur de réglage	Remarques	
Normal (NORM)	Enregistrement (REC)	Appliquer un signal de 2kHz -10dBv (316mV) sur les bornes d'enregistrement.	1	Contrôle de niveau d'enregistrement.	TP1 gauche (L) TP2 droit (R)	-2,2dBv (775mV)	
			2	Commutateur DOLBY NR .....ON			
Normal (NORM)	Enregistrement (REC)	Appliquer un signal de 2kHz -30dBv (31,6 mV) sur les bornes d'enregistrement.	3	VR701	TP1 gauche (L) TP2 droit (R)	-17,9dBv±0,2dB	
<b>2. Réglage de l'azimutage de la tête</b> ● Placer le VR302 et le VR402 (Réglage de niveau de reproduction) sur la position maximale (tourner complètement dans le sens des aiguilles d'une montre).							
Sélecteur de bande	Mode	Signal d'entrée/bande d'essai	Emplacement du réglage	Emplacement de mesure	Valeur de réglage	Remarques	
Normal (NORM)	Reproduction (PLAY)	Reproduire la portion 10kHz -20dB de la bande d'essai STD-331B.	Vis de réglage de l'azimutage de la tête. (Fig. 10-3)	Bornes de reproduction droite et gauche (L + R).	Niveau de signal de reproduction maximal.	Mettre en place "l'arrêt de vis" après avoir effectué ce réglage.	
<b>3. Réglage de l'égalisateur de reproduction</b> ● Régler le VR302 et VR402 (Réglage de niveau de reproduction) sur la position centrale.							
Sélecteur de bande	Mode	Signal d'entrée/bande d'essai	Emplacement du réglage	Emplacement de mesure	Valeur de réglage	Remarques	
Normal (NORM)	Reproduction (PLAY)	Reproduire les portions 315Hz -20dB et 6,3Hz -20dB de la bande d'essai STD-331B.	VR301 gauche (L) VR401 droit (R)	Bornes de reproduction droite et gauche (L + R).	Le niveau de reproduction à 6,3kHz doit être compris entre -0,5 ±0,5dB du niveau à 315Hz (Voir la réponse en fréquences de reproduction sur la Fig. 10-4).		
<b>4. Réglage du niveau de reproduction</b> ● Procéder à ce réglage avec précision car celui-ci détermine le niveau de reproduction du DOLBY.							
Sélecteur de bande	Mode	Signal d'entrée/bande d'essai	Emplacement du réglage	Emplacement de mesure	Valeur de réglage	Remarques	
Normal (NORM)	Reproduction (PLAY)	Reproduire la portion 315Hz 0dB de la bande d'essai STD-331B.	VR302 gauche (L) VR402 droit (R)	TP1 gauche (L) TP2 droit (R)	-5,2dBv (550mV)		
<b>5. Vérification de l'affichage indicateur de niveau</b>							
Sélecteur de bande	Mode	Signal d'entrée/bande d'essai	Emplacement du réglage	Emplacement de mesure	Valeur de réglage	Remarques	
Normal (NORM)	Enregistrement (REC)	Appliquer un signal 315Hz -10dBv (316mV) aux bornes d'enregistrement.	1	Contrôle de niveau d'enregistrement.	Affichage indicateur de niveau	0dB	
			2		TP1 gauche (L) TP2 droit (R)	-5,2dBv +0,5dB	
<b>6. Réglage de la réponse en fréquences d'enregistrement et de reproduction</b>							
Sélecteur de bande	Mode	Signal d'entrée/bande d'essai	Emplacement du réglage	Emplacement de mesure	Valeur de réglage	Remarques	
Normal (NORM)	Enregistrement (REC)	Appliquer un signal de 315Hz -30dBv (31,6mV) sur les bornes d'enregistrement.	1	Contrôle de niveau d'enregistrement.	TP1 gauche (L) TP2 droit (R)	-25,2dBv (55mV)	
Normal (NORM)	Enregistrement/reproduction (REC/PLAY)	Enregistrer des signaux de 315Hz et 6,3kHz sur la bande d'essai STD-608A, et reproduire ensuite les signaux.	2	VR304 gauche (L) VR404 droit (R)	TP1 gauche (L) TP2 droit (R)	Recommencer les procédures d'enregistrement et de reproduction, et procéder au réglage en conséquence jusqu'à ce que le niveau de reproduction du 6,3kHz soit compris entre +1,0 ±0,5dB du niveau du 315Hz.	
● Changer la bande d'essai et la position du commutateur de réducteur de bruit DOLBY, et vérifier que la courbe de réponse en fréquences indiquée sur la Fig. 10-5 est respectée. Si les courbes de réponse ne sont pas satisfaisantes, il est possible de régler à nouveau le niveau de reproduction du 6,3kHz entre +1,0 ±0,5 dB du niveau du 315Hz.							

7. Réglage du niveau d'enregistrement							
Sélecteur de bande	Mode	Signal d'entrée/bande d'essai		Emplacement du réglage	Emplacement de mesure	Valeur de réglage	Remarques
Normal (NORM)	Enregistrement (REC)	Appliquer un signal de 315 Hz -10dBv (315mV) sur les bornes d'enregistrement.	1	Contrôle de niveau d'enregistrement	TP1 gauche (L) TP2 droit (R)	-5,2dBv (550mV)	
Normal (NORM)	Enregistrement/reproduction (REC/PLAY)	Enregistrer le signal de 315 Hz sur la bande d'essai STD-608A, puis reproduire le signal.	2	VR303 gauche (L) VR403 droit (R)	TP1 gauche (L) TP2 droit (R)	Recommencer les procédures d'enregistrement et de reproduction, et procéder au réglage jusqu'à ce que un niveau de reproduction de -5,2dBv (550mV) soit obtenu.	
Oxyde de chrome (CrO <sub>2</sub> )	Enregistrement/reproduction (REC/PLAY)	Enregistrer le signal de 315Hz sur la bande d'essai STD-603, puis reproduire le signal.	3		TP1 gauche (L) TP2 droit (R)	Vérifier que le niveau de reproduction du 315Hz est à -5,2dBv ±1,5dB.	
Métal (METAL)	Enregistrement/reproduction (REC/PLAY)	Enregistrer le signal de 315Hz sur la bande d'essai STD-604, puis reproduire le signal.	4		TP1 gauche (L) TP2 droit (R)	Vérifier que le niveau de reproduction du 315Hz est à -5,2dBv ±1,5dB.	

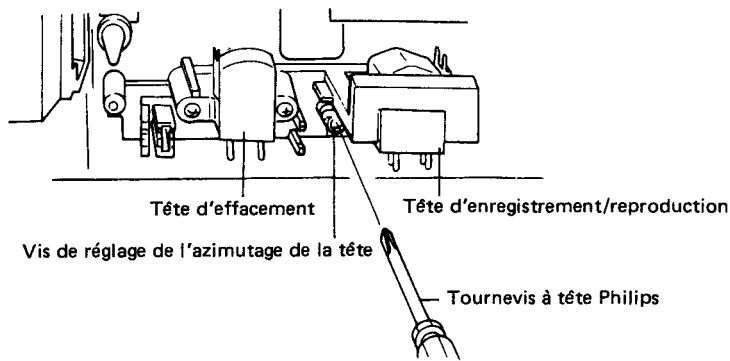

Fig. 10-3 Réglage de l'azimutage de la tête

Le CT-1040W offre un mécanisme de sélection automatique de bande.

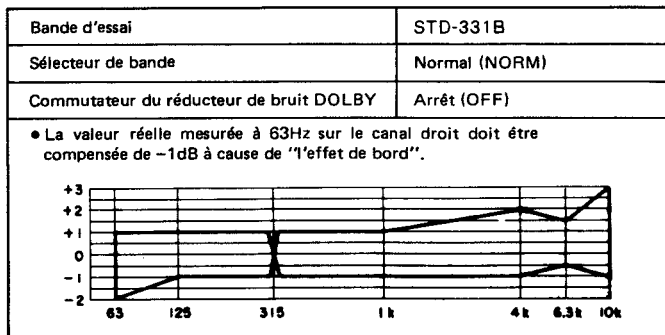

Fig. 10-4 Réponse en fréquences de reproduction

**Le CT-1040W offre un mécanisme de sélection automatique de bande**

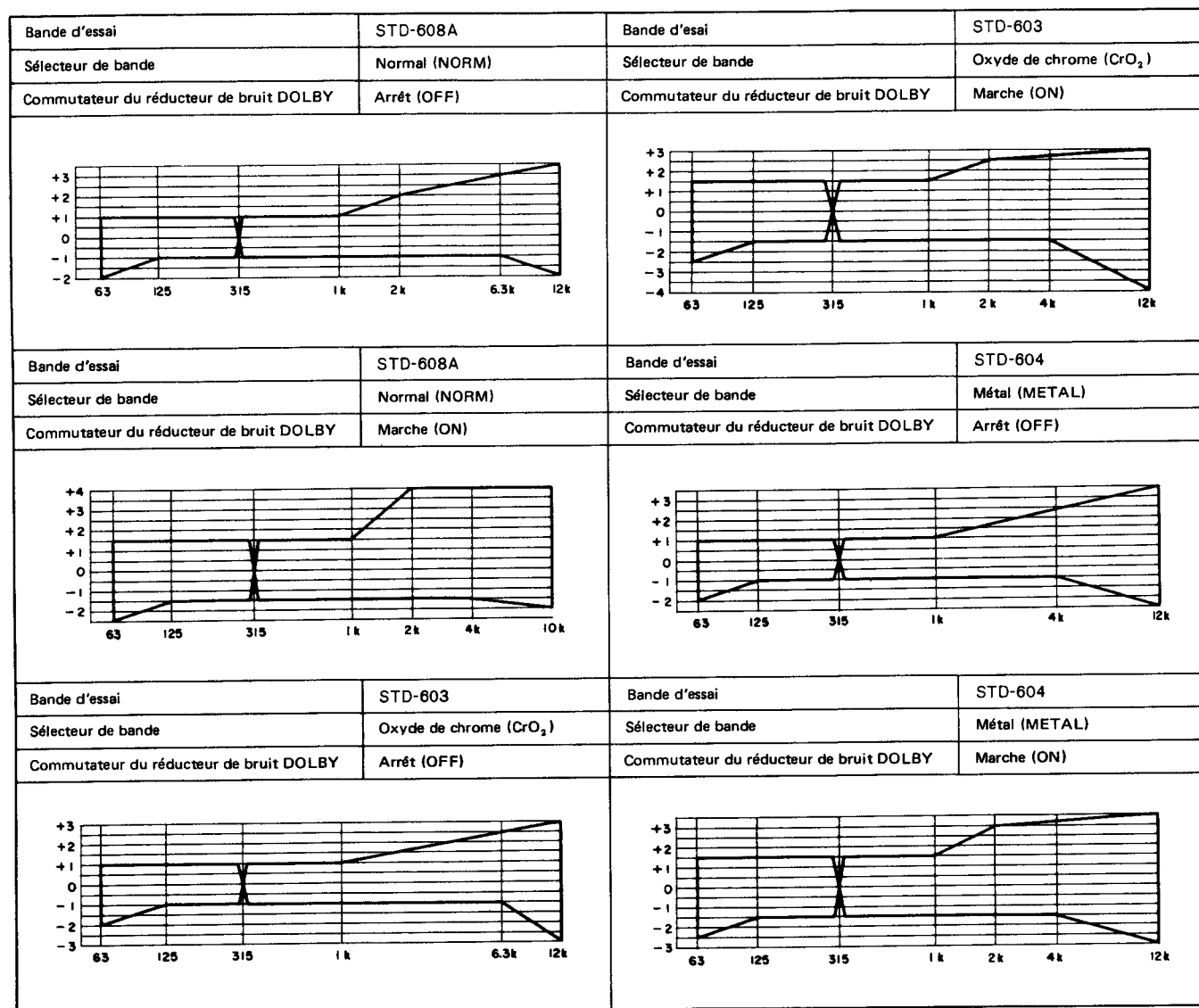

Fig. 10-5 Réponse en fréquences globales

**Le CT-1040Z offre un mécanisme de sélection automatique de bande**

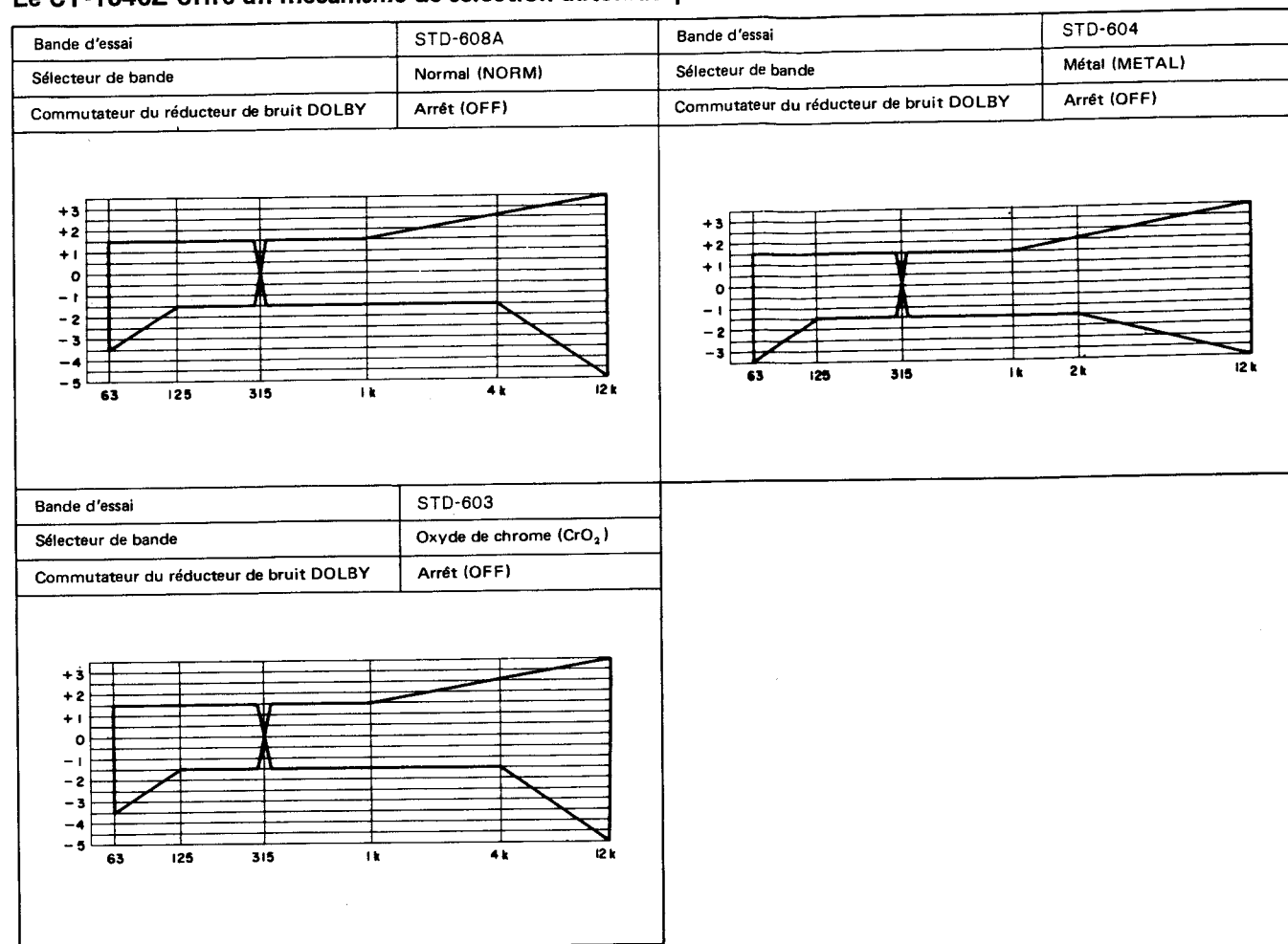

Fig. 10-6 Réponse en fréquences de reproduction

# 10. AJUSTE

## 10.1 AJUSTES MECANICOS

- Antes de iniciar cualquier ajuste mecánico, limpiar el eje de arrastre, rodillo de presión, polea loca, y correas con un paño humedecido en un poco de alcohol.
- A menos que se indique especialmente, los ajustes siguientes se refieren a los magnetófonos A y B.

**1. Comprobación de la presión del rodillo de presión**  
• Emplear el medidor de tensión (GGK-047)

Modo	Valores de especificaciones	Condiciones
PLAY	230g ~ 350g	Dejar que el rodillo de presión se acerque lentamente al eje de arrastre y leer el valor del medidor de tensión cuando el rodillo de presión empieza a girar.

• Cambiar el muelle de presión del rodillo de presión (RBH-890)

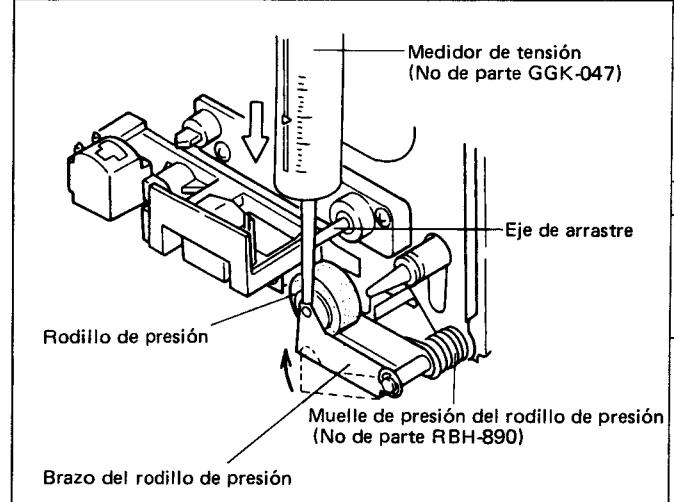
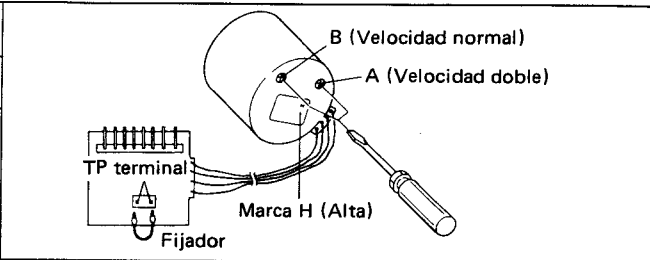

**4. Ajuste del solenoide de FF**

Modo	Lugar de ajuste	Especificaciones
FF	Posición del solenoide de FF (Aflojar los tornillos (1) para permitir el movimiento).	El orificio cuadrado del conjunto completo de la base del carrete debe estar en contacto con el buje del conjunto completo del brazo impulsor.

**5. Ajuste del solenoide de REW**

Modo	Lugar de ajuste	Especificaciones
REW	Posición del solenoide REW (Aflojar los tornillos (2) para permitir el movimiento).	El orificio cuadrado del conjunto completo de la base del carrete debe estar en contacto con el conjunto completo del brazo impulsor.

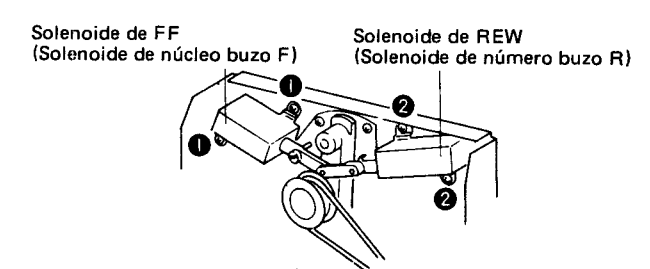

**2. Comprobación del par de torsión de la base del carrete**  
• Emplear el medidor de par de torsión (GGK-056)

Modo	Valores de torsión de la base del carrete de arrastre	Valores de torsión de la base del carrete de suministro
PLAY	35g-cm ~ 55g-cm	*2g-cm ~ 5g-cm
FF	85g-cm ~ 125g-cm	*2g-cm ~ 5g-cm
REW	*2g-cm ~ 5g-cm	85g-cm ~ 125g-cm

\* Par de torsión de retrotensión.

■ Si no se satisfacen los valores de los pares de torsión, cambiar el conjunto de la base del carrete de suministro (RXB-714), conjunto de la base del carrete de arrastre (RXB-715) y conjunto completo del brazo impulsor (RXB-376).

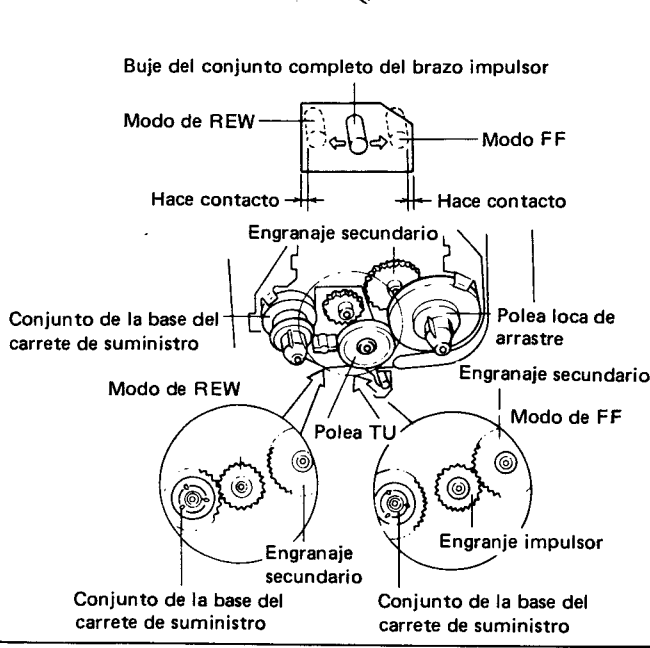

**3. Ajuste de la velocidad de la cinta**  
• Ajustar al principio de la cinta

Mode	Cinta de prueba	Lugar de ajuste	Valores de especificaciones (Frecuencia de reproducción)
Velocidad doble PLAY	STD-301 (3kHz)		6010Hz±10Hz
Velocidad normal PLAY	STD-301 (3kHz)		3010Hz±5Hz

1. Cortocircuitar el terminal TP, y ajustar desde velocidad doble.
2. Abrir el terminal TP ajustar en velocidad normal.
3. La velocidad de la cinta del magnetófono B no debe desviarse de la velocidad de la cinta del magnetófono A en más de ±10Hz a la velocidad doble, ni en más de ±5Hz a la velocidad normal.

**6. Ajuste de la localización de canciones (Magnetófono A)**

Modo	Lugar de ajuste	Especificaciones
MS	Ver el diagrama de abajo	Empleando un destornillador insertado en la ranura (A) de la palanca (B), ajustar las dimensiones de G indicadas en el diagrama siguiente a 7,8~8,1mm.

**8. Ajuste del detector de cintas de cromo (Magnetófono A)**

Lugar de ajuste	Método de ajuste
Palanca del detector de cintas de cromo	Ajustar S2201 para activarse cuando se cargue la cinta de prueba STD-603, y S2201 para desactivarse al cargar la cinta de prueba STD-608A.

**7. Ajuste de la expulsión**

Lugar de ajuste	Método de ajuste
Palanca del detector de cintas de cromo	Ajustar el entrehierros C a 0~0,5mm cuando el compartimiento está cerrado sin ningún casete cargado.
Punto de comprobación	Cerciorarse de que existe el entrehierros entre el casete y la palanca del detector.

**9. Ajuste del detector de cintas de cromo (Magnetófono B)**

Lugar de ajuste	Método de ajuste
Palanca del detector de cintas de cromo	Ajustar S2301 para activarse al cargar la cinta de prueba STD-603, y S2301 para desactivarse al cargar la cinta de prueba STD-608A.
Palanca del detector de cintas de metal	Ajustar S2302 para activarse al cargar la cinta de prueba STD-604, y S2302 para desactivarse al cargar la cinta de prueba STD-608A.

10.2 AJUSTES ELECTRICOS

■ Antes de iniciar cualquier ajuste, cerciorarse de haber completado y comprobado lo siguiente.

1. Deben haberse completo todos los ajustes mecánicos.
2. Las cabezas deben estar limpias y desmagnetizadas.
3. Conectar una resistencia ficticia de 50K ohmios 47 ~ 52k ohmios) al terminal OUTPUT con 0dB = 1V durante las mediciones del nivel.
4. Emplear las cintas especificadas para cada ajuste. Aunque estas cintas están provistas de ambos lados, A y B, emplear sólo el lado A, donde está la etiqueta.  
STD-331B : Ajuste de reproducción.  
STD-608A : Cinta en blanco NORMAL.  
STD-603 : Cinta en blanco de CrO<sub>2</sub>.  
STD-604 : Cinta en blanco de METAL.
5. Preparar el siguiente equipo de medición: Un voltímetro de CA, un generador de sonido, un atenuador y un osciloscopio.
6. Ajustar los canales izquierdo y derecho a menos que se especifique lo contrario.
7. Y a menos que se diga lo contrario, dejar el interruptor DOLBY NR en la posición OFF.

8. Dejar que se precaliente el aparato durante algunos minutos antes de iniciar los ajustes. Y antes de empezar el ajuste de la respuesta en frecuencia para reproducción y grabación, dejar que se precaliente de tres a cinco minutos.
9. Ajustar siempre el aparato en el orden de ajuste dado. Si se cambia el orden, no son posibles los ajustes adecuados, lo cual puede ocasionar pérdida del rendimiento.

Procedimientos de ajuste

Magnetófono A

1. Ajuste del acimut de la cabeza.
2. Ajuste del ecualizador de reproducción.
3. Ajuste del nivel de reproducción.

Magnetófono B

1. Ajuste del nivel de reducción de ruido DOLBY.
2. Ajuste del acimut de la cabeza.
3. Ajuste del ecualizador de reproducción.
4. Ajuste del nivel de reproducción.
5. Comprobación de la indicación del medidor de nivel.
6. Respuesta en frecuencia de grabación/reproducción.
7. Ajuste del nivel de grabación.

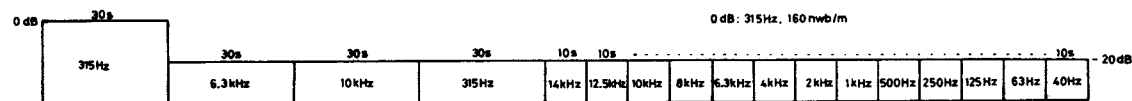

Fig. 10-1 Cinta de prueba STD-331B

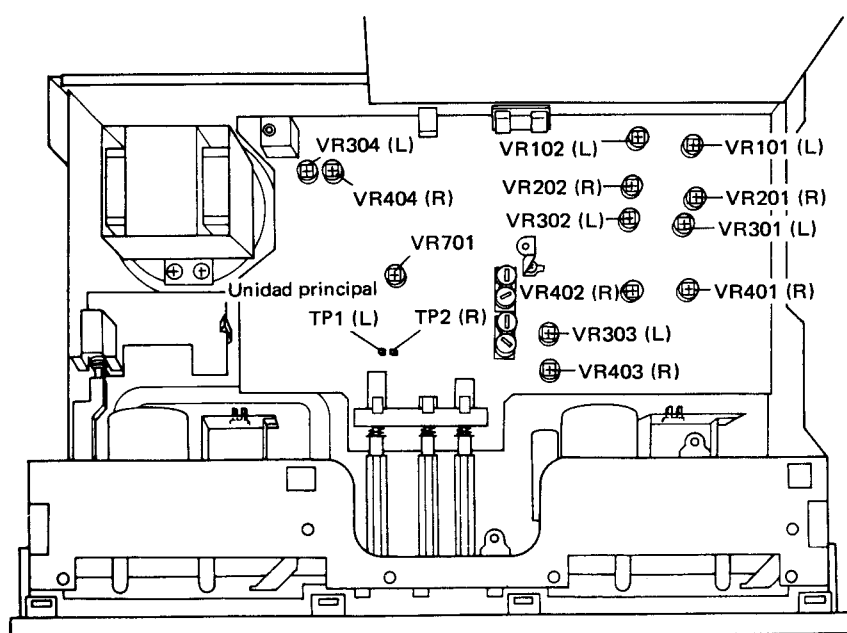

Fig. 10-2 Lugares de ajuste

● Magnetófono A

Ajuste del ecualizador de reproducción  
VR101 (izq.) (L)  
VR201 (der.) (R)  
Ajuste del nivel de reproducción  
VR102 (izq.) (L)  
VR202 (der.) (R)

● Magnetófono B

Ajuste de reducción de ruido Dolby  
VR701  
Ajuste del ecualizador de reproducción  
VR301 (izq.) (L)  
VR401 (der.) (R)  
Ajuste del nivel de reproducción  
VR302 (izq.) (L)  
VR402 (der.) (R)  
Ajuste de la respuesta en frecuencia de grabación/reproducción  
VR304 (izq.) (L)  
VR404 (der.) (R)  
Ajuste del nivel de grabación  
VR303 (izq.) (L)  
VR403 (der.) (R)

● AJUSTE DEL MAGNETOFONO A (Sin la función del selector automático de cintas)						
<b>1. Ajuste del acimut de la cabeza</b> ● Ajustar VR102 y VR202 (Ajuste del nivel de reproducción) a las posiciones MAX (Girados completamente a la derecha)						
Selector de cintas	Modo	Señal de entrada/cinta de prueba	Lugar de ajuste	Lugar de medición	Valor de ajuste	Observaciones
NORM	PLAY	Reproducir la parte de 10kHz -20dB de la cinta de prueba STD-331B.	Tornillo de ajuste del acimut de la cabeza. (Fig. 10-3)	Terminales de reproducción izquierdo y derecho.	Nivel máximo de señal de reproducción.	Aplicar el "enclavamiento del tornillo" después de finalizar el ajuste.
<b>2. Ajuste del ecualizador de reproducción</b> ● Ajustar VR101 y VR202 (Ajuste del nivel de reproducción) a las posiciones centrales físicas.						
Selector de cintas	Modo	Señal de entrada/cinta de prueba	Lugar de ajuste	Lugar de medición	Valor de ajuste	Observaciones
NORM	PLAY	Reproducir las partes de 315Hz -20dB y de 6,3kHz -20dB de la cinta de prueba STD-331B.	VR101 (L) VR201 (R)	Terminales de reproducción izquierdo y derecho.	El nivel de reproducción a 6,3kHz debe estar dentro de -0,5±0,5dB del nivel a 315Hz (Ver la respuesta en frecuencia de reproducción de la Fig. 10-4).	
<b>3. Ajuste del nivel de reproducción</b> ● Ajustar con precisión porque este ajuste establece el nivel del sistema Dolby para reproducción.						
Selector de cintas	Modo	Señal de entrada/cinta de prueba	Lugar de ajuste	Lugar de medición	Valor de ajuste	Observaciones
NORM	PLAY	Reproducir la parte de 315Hz 0dB de la cinta de prueba 331B.	VR102 (L) VR202 (R)	TP1 (L) TP2 (R)	-5,2dBv (550mV)	
● AJUSTE DEL MAGNETOFONO B (Con la función del selector automático de cintas)						
<b>1. Ajuste del nivel de reducción de ruido Dolby</b>						
Selector de cintas	Modo	Señal de entrada/cinta de prueba	Lugar de ajuste	Lugar de medición	Valor de ajuste	Observaciones
NORM	REC	Aplicar una señal de 2kHz -10dBv (316mV) a los terminales de grabación.	1	Control del nivel de grabación	TP1 (L) TP2 (R)	-2,2dBv (775mV)
			2	Interruptor DOLBY NR.....ON		
NORM	REC	Aplicar una señal de 2kHz -30dBv (31,6mV) a los terminales de grabación.	3	VR701	TP1 (L) TP2 (R)	-17,9dBv±0,2dBv
<b>2. Ajuste del acimut de la cabeza</b> ● Ajustar VR302 y VR402 (Ajuste del nivel de reproducción) a las posiciones MAX (Girados completamente a la derecha)						
Selector de cintas	Modo	Señal de entrada/cinta de prueba	Lugar de ajuste	Lugar de medición	Valor de ajuste	Observaciones
NORM	PLAY	Reproducir la parte de 10kHz -20dB de la cinta de prueba STD-331B.	Tornillo de ajuste del acimut de la cabeza. (Fig. 10-3)	Terminales de reproducción izquierdo y derecho. L.R.	Nivel máximo de la señal de reproducción.	Aplicar el "enclavamiento del tornillo" después de terminar el ajuste.
<b>3. Ajuste del ecualizador de reproducción</b> ● Ajustar VR302 y VR402 (Ajuste de nivel de reproducción) a las posiciones centrales físicas.						
Selector de cintas	Modo	Señal de entrada/cinta de prueba	Lugar de ajuste	Lugar de medición	Valor de ajuste	Observaciones
NORM	PLAY	Reproducir la parte de 315Hz -20dB y la de 6,3kHz -20dB de la cinta de prueba STD-331B.	VR301 (L) VR401 (R)	Terminales de reproducción izquierdo y derecho. L.R.	El nivel de reproducción a 6,3kHz debe estar dentro de -0,5±0,5dB del nivel a 315Hz (Ver la respuesta en frecuencia de reproducción de la Fig. 10-4).	
<b>4. Ajuste del nivel de reproducción</b> ● Ajustar con precisión porque este ajuste establece el nivel del sistema Dolby de reproducción.						
Selector de cintas	Modo	Señal de entrada/cinta de prueba	Lugar de ajuste	Lugar de medición	Valor de ajuste	Observaciones
NORM	PLAY	Reproducir la parte de 315Hz 0dBv de la cinta de prueba STD-331B.	VR302 (L) VR402 (R)	TP1 (L) TP2 (R)	-5,2dBv (550mV)	
<b>5. Comprobación de la indicación del medidor de nivel</b>						
Selector de cintas	Modo	Señal de entrada/cinta de prueba	Lugar de ajuste	Lugar de medición	Valor de ajuste	Observaciones
NORM	REC	Aplicar la señal de 315Hz -10dBv (316mV) a los terminales de grabación.	1	Control del nivel de grabación	Indicador del medidor de nivel	0dB
			2		TP1 (L) TP2 (R)	-5,2dBv +0,5dB
<b>6. Ajuste de la respuesta en frecuencia para grabación/reproducción</b>						
Selector de cintas	Modo	Señal de entrada/cinta de prueba	Lugar de ajuste	Lugar de medición	Valor de ajuste	Observaciones
NORM	REC	Aplicar una señal de 315Hz -30dBv (31,6mV) a los terminales de grabación.	1	Control del nivel de grabación	TP1 (L) TP2 (R)	-25,2dBv (55mV)
NORM	REC/PLAY	Grabar las señales de 315 Hz y de 6,3kHz en la cinta de prueba STD-608A, y luego reproducirlas.	2	VR304 (L) VR404 (R)	TP1 (L) TP2 (R)	Repetir los procesos de grabación y reproducción y ajustar consecuentemente hasta que el nivel de reproducción de 6,3kHz esté dentro de +1,0 ±0,5dB del nivel de 315Hz.
● Cambiar la cinta de prueba y la posición del interruptor DOLBY NR y comprobar que la zona de respuesta en frecuencia indicada en la Fig. 10-5 se satisfaga. Si las curvas de la respuesta son insatisfactorias, el nivel de reproducción de 6,3kHz podrá reajustarse a dentro de +1,0 ±0,5 dB del nivel de 315Hz.						

7. Ajuste del nivel de grabación						
Selector de cintas	Modo	Señal de entrada/cinta de prueba	Lugar de ajuste	Lugar de medición	Valor de ajuste	Observaciones
NORM	REC	Aplicar una señal de 315 Hz -10dBv (315mV) a los terminales de grabación.	1	Control del nivel de grabación	TP1 (L) TP2 (R)	-5,2dBv (550mV)
NORM	REC/PLAY	Grabar la señal de 315Hz en la cinta de prueba STD-608A y reproducirlas.	2	VR303 (L) VR403 (R)	TP1 (L) TP2 (R)	Repetir los procesos de grabación y ajustar consecuentemente hasta que se obtenga un nivel de reproducción de -5,2dBv (550mV).
CrO <sub>2</sub>	REC/PLAY	Grabar la señal de 315Hz en la cinta de prueba STD-603, y reproducirla.	3		TP1 (L) TP2 (R)	Comprobar que el nivel de reproducción de 315Hz sea de -5,2dBv±1,5dB.
METAL	REC/PLAY	Grabar la señal de 315Hz en la cinta de prueba STD-604 y reproducirla.	4		TP1 (L) TP2 (R)	Comprobar que el nivel de reproducción de 315Hz sea de -5,2dBv±1,5dB.

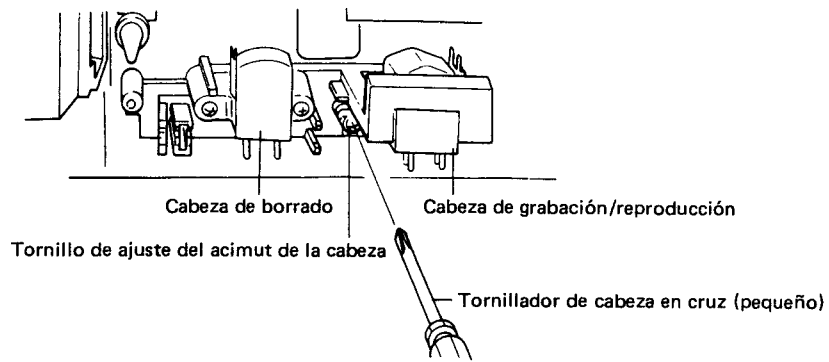

Fig. 10-3 Ajuste del acimut de la cabeza

El CT-1040W está provisto de un mecanismo selector automático de cintas.

Cinta de prueba	STD-331B
Selector de cintas	NORM
Interruptor DOLBY NR	OFF
<p>● El valor real medido a 63Hz en el canal derecho tiene que compensarse en -1dB debido al "efecto de borde".</p>	

Fig. 10-4 Respuesta en frecuencia de reproducción

El CT-1040W está provisto de un mecanismo selector automático de cintas

Cinta de prueba	STD-608A	Cinta de prueba	STD-603
Selector de cintas	NORM	Selector de cintas	CrO <sub>2</sub>
Interruptor DOLBY NR	OFF	Interruptor DOLBY NR	ON
Cinta de prueba	STD-608A	Cinta de prueba	STD-604
Selector de cintas	NORM	Selector de cintas	METAL
Interruptor DOLBY NR	ON	Interruptor DOLBY NR	OFF
Cinta de prueba	STD-603	Cinta de prueba	STD-604
Selector de cintas	CrO <sub>2</sub>	Selector de cintas	METAL
Interruptor DOLBY NR	OFF	Interruptor DOLBY NR	ON

Fig. 10-5 Frecuencia global

El CT-1040W está provisto de un mecanismo selector automático de cintas

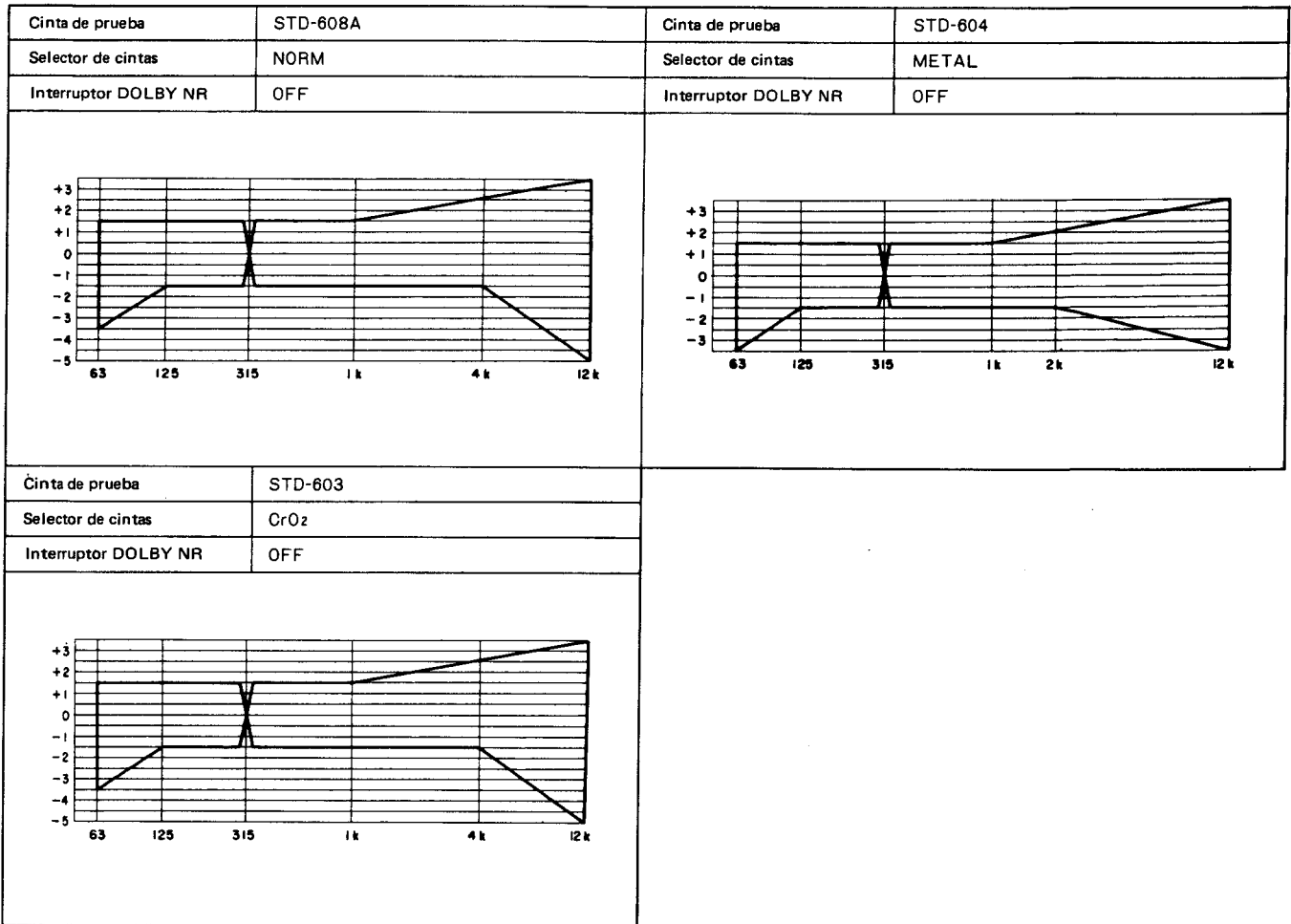

Fig. 10-6 Respuesta en frecuencia de copiado

# 11. SAFETY INFORMATION

## 1. SAFETY PRECAUTIONS

The following check should be performed for the continued protection of the customer and service technician.

### LEAKAGE CURRENT CHECK

Measure leakage current to a known earth ground (water pipe, conduit, etc.) by connecting a leakage current tester such as Simpson Model 229-2 or equivalent between the earth ground and all exposed metal parts of the appliance (input/output terminals, screwheads, metal overlays, control shaft, etc.). Plug the AC line cord of the appliance directly into a 120V AC 60Hz outlet and turn the AC power switch on. Any current measured must not exceed 0.5mA.

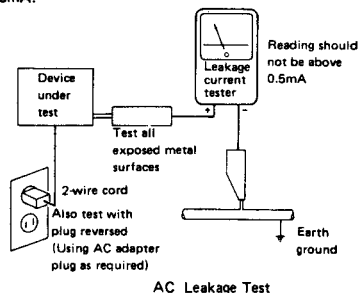

ANY MEASUREMENTS NOT WITHIN THE LIMITS OUTLINED ABOVE ARE INDICATIVE OF A POTENTIAL SHOCK HAZARD AND MUST BE CORRECTED BEFORE RETURNING THE APPLIANCE TO THE CUSTOMER.

## 2. PRODUCT SAFETY NOTICE

Many electrical and mechanical parts in the appliance have special safety related characteristics. These are often not evident from visual inspection nor the protection afforded by them necessarily can be obtained by using replacement components rated for voltage, wattage, etc. Replacement parts which have these special safety characteristics are identified in this Service Manual.

Electrical components having such features are identified by marking with a  $\beta$  on the schematics and on the parts list in this Service Manual.

The use of a substitute replacement component which does not have the same safety characteristics as the PIONEER recommended replacement one, shown in the parts list in this Service Manual, may create shock, fire, or other hazards.

Product Safety is continuously under review and new instructions are issued from time to time. For the latest information, always consult the current PIONEER Service Manual. A subscription to, or additional copies of, PIONEER Service Manual may be obtained at a nominal charge from PIONEER.

## 12. SUPPLEMENT FOR HE, HB AND HP TYPES

Model CT-1040W/HE, HB and HP types are the CT-1040W/KU with the exception of this supplement.

### 12.1 SPECIFICATIONS

Power Requirements . . . . . AC220V/240V, 50/60Hz  
 Power Consumption . . . . . 33 Watts

### 12.2 CONTRAST OF MISCELLANEOUS PARTS

Mark	Symbol & Description	Part No.			
		KU type	HE type	HB type	HP type
⚠ ★	Power transformer (120V) (220V/240V)	RTT-333	.....	.....	.....
⚠	Power cord	RDG-048	RDG-053	.....	RDG-029
⚠	Power cord assembly	.....	.....	RDG-052	.....
⚠ ★	Fuse (1.25A)	REK-073	.....	.....	.....
⚠ ★	Fuse (3.15A)	.....	REK-047	REK-047	REK-047
⚠ ★	Fuse (500mA)	.....	REK-049	REK-049	REK-049
⚠	Strain relief	REC-395	REC-396	REC-396	REC-396
	Packing case	RHG-630	RHG-631	RHG-631	RHG-631
	Operating instructions (English/German/ French/Italian)	RRB-219	.....	RRB-219	RRB-219
	(English)	.....	RRE-049	.....	.....
	Main assembly	RWX-792	RWX-847	RWX-847	RWX-847

### 12.3 P.C. BOARD ASSEMBLIES

- Main assembly RWX-847 (for HE, HB and HP types) is the same as the RWX-792 (for KU type) with the exception of following sections.

	Symbol & Description	for KU type	for HE, HB and HP types
⚠ ★	D701	1B2C1-LC2	S3VC 10R
⚠ ★	D702	1B2Z1-LC2	S3VC 10
	C703	.....	RCH-054
⚠	FN19100J	.....	REK-085

- Control assembly for HE, HB and HP types is the same as the control assembly for KU type with the exception of following sections.

	Symbol & Description	for KU type	for HE, HB and HP types
⚠ ★	D801	1B2C1-LC2	.....
⚠ ★	D802	1B2Z1-LC2	.....
	C801	RCH-054	.....
	C821, C822	.....	CKDYF 473Z 50

- Power switch assembly for HE, HB and HP types is the same as the power switch assembly for KU type with the exception of following sections.

Symbol & Description	for KU type	for HE, HB and HP type
C2101	RCG-008	RCG-009

12.4 POWER SUPPLY CIRCUIT FOR HE, HB AND HP TYPES

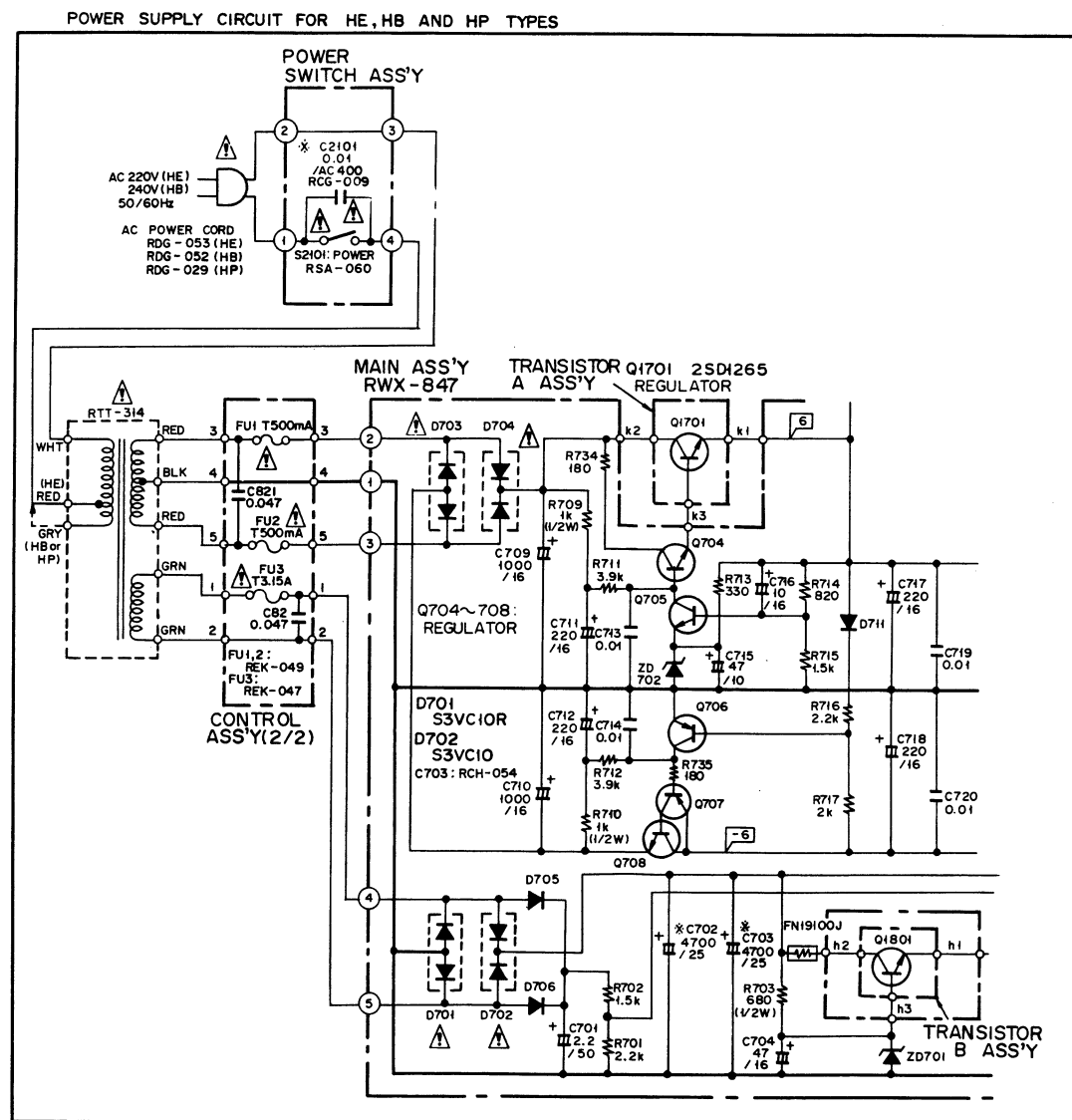

12.5 CONTROL ASSEMBLY FOR HE, HB AND HP TYPES

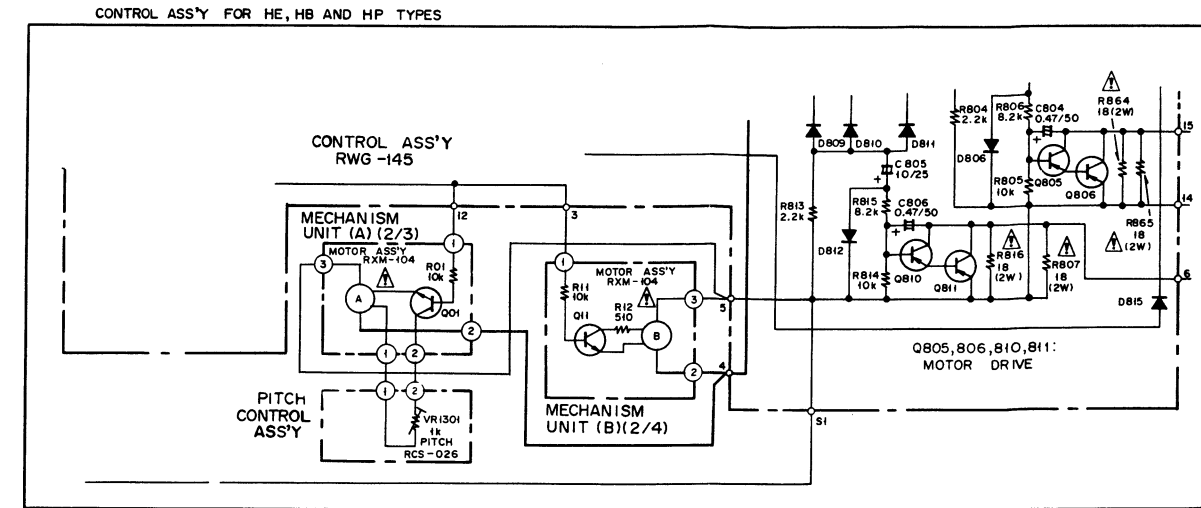

### 13. SLIPPLEMENT FOR D AND D/G TYPES

Model CT-1040W/D and D/G types are the CT-1040W/KU with the exception of this supplement.

#### 13.1 SPECIFICATIONS

Power Requirements . . . . . AC120/220/240V, 50/60Hz (switchable)

Power Consumption . . . . . 24 Watts

#### 13.2 CONTRAST OF MISCELLANEOUS PARTS

Mark	Symbol & Description	Part No.			Remarks
		KU type	D type	D/G type	
△ ★	Power transformer (120V) (120V/220V/240V)	RTT-333	.....	.....	
△	Connector 5P	RKP-854	.....	.....	
△	Power cord	RDG-048	RDG-051	RDG-051	
★	Fuse (1.25A)	REK-073	.....	.....	
△	Voltage selector	.....	RSX-057	RSX-057	
	Packing case	RHG-630	RHG-632	RHG-633	
		.....	.....	RHC-077	
		.....	.....	RHC-089	
		.....	.....	RHC-090	
	Operating instructions (English/German/ French/Italian)	RRB-219	RRB-219	RRB-219	
	(English)	.....	RRD-063	RRD-063	
	Main ass'y	RWX-792	RWX-848	RWX-848	

#### 13.3 P.C. BOARD ASSEMBLIES

● Main assembly RWX-848 (for D and D/G types) is the same as the RWX-792 (for KU type) with the exception of following sections.

Symbol & Description	for KU type	for D and D/G types
★★ Q806, Q811	2SA881	.....
★★ Q805, Q810	2SA933LN	.....
★ D803-D806, D809-D812	1S2473	.....
★ D801	1B2C1-LC2	.....
★ D802	1B2Z1-LC2	.....
C801	RCH-054	.....
C804, C806	CEA R47M 50	.....
C803, C805	CEA 100M 25	.....
C821, C822	RS2LF 180J	.....
R804, R813	RD1/6PM 222J	.....
R806, R815	RD1/6PM 822J	.....
R805, R814	RD1/6PM 103J	.....

● Control assembly for D and D/G types is the same as the control assembly for KU type with the exception of following sections.

Symbol & Description	for KU type	for D and D/G types
△ ★ D701	1B2C1-LC2	S3VC10R
△ ★ D702	1B2Z1-LC2	S3VC10
C703	.....	RCH-054
R734, R735	RD1/6PM 101J	.....
R736	RD1/6PM 6R8J	.....

#### 13.4 POWER SUPPLY CIRCUIT FOR D AND D/G TYPES

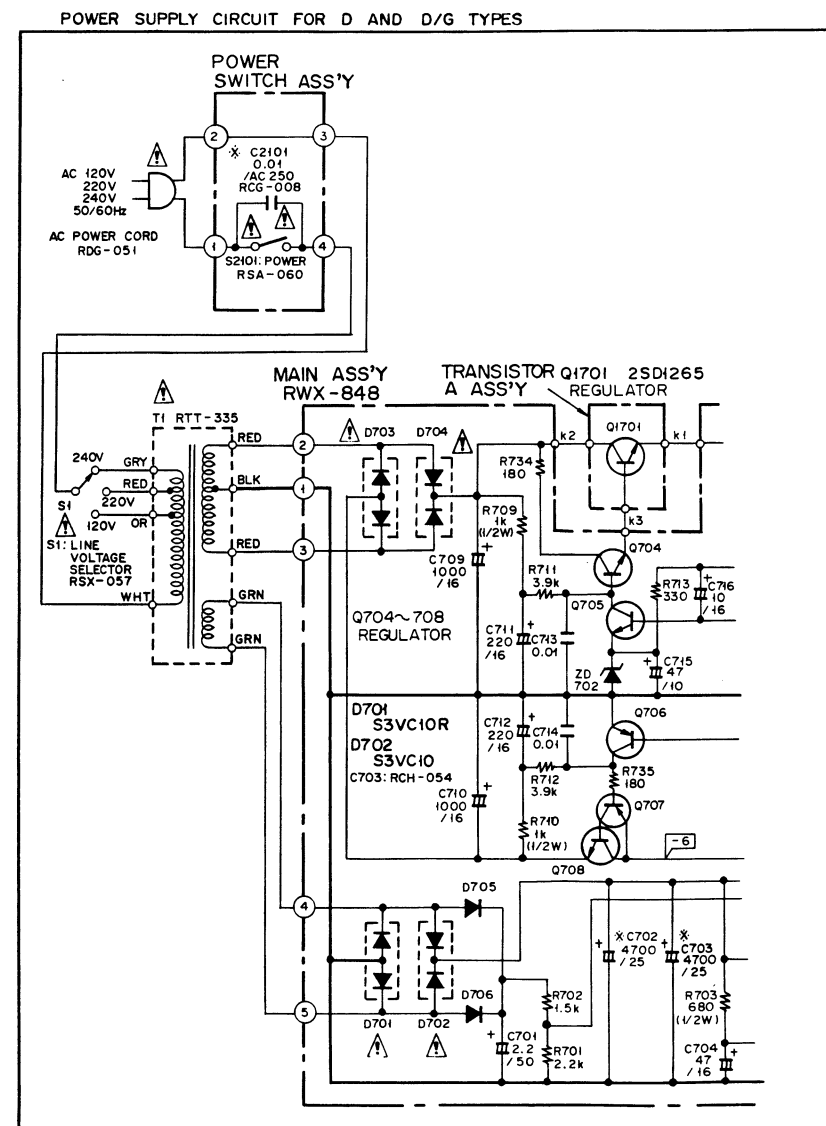

13.5 CONTROL ASSEMBLY FOR D AND D/G TYPES

