

# **ALLIED<sup>®</sup>**

MODEL
<b>490</b>

## **SOLID STATE STEREO AM/FM RECEIVER**

### **INSTALLATION AND OPERATING INSTRUCTIONS**

To get the finest performance from your receiver.

**READ THIS INSTRUCTION MANUAL NOW**

and Keep it as a handy reference

**ALLIED RADIO CORPORATION**

100 N. Western Avenue, Chicago, Illinois 60680

## **UNPACKING**

Your Allied receiver is packed as a complete assembly, ready to operate. After unpacking the receiver from its protective shipping carton inspect it carefully. Any damage should be reported immediately. File a report with the claims division of the delivery agent and return the completed form, together with your order papers, to Allied for a prompt adjustment.

## **INSTALLATION**

When installing your stereo system, check the following points.

- \* The area should be well-ventilated, and free from dampness and dust.
- \* The units should not be exposed to direct sunlight.
- \* The units should not be placed near radiators or other heating units.
- \* The place should be substantial and roomy enough for the installation, when installing the unit on a shelf.

## **FEATURES**

### **FM FRONT-END EMPLOYING A FIELD EFFECT TRANSISTOR TO HEAR MORE STATIONS MORE CLEARLY**

By the use of FET (field effect transistor) in the FM radio frequency amplifier stage, design of nearly perfect FM front-end was achieved—free from cross modulation, free from drift, with better sensitivity, lower inherent noise, and high spurious rejection ratio.

### **INTEGRATED CIRCUIT (IC) EMPLOYED IN FM TUNER ASSURES OUTSTANDING CAPTURE RATIO WITH HIGH RELIABILITY**

In the FM intermediate frequency amplifier stage, integrated circuits are employed, resulting in an entirely different outstanding performance from that of IF stages hitherto designed, especially in the limiter characteristic and the capture ratio.

### **MULTIPLEX CIRCUITRY (MPX) FOR MAXIMUM CHANNEL SEPARATION**

The accurate electronic switching circuitry is employed in the FM multiplex demodulator, insuring maximum separation with excellent quality.

### **HIGH PERFORMANCE SINGLE-ENDED PUSH-PULL (SEPP) OUTPUT CIRCUITS**

The power amplifier employs high-performance single-ended push-pull circuitry in the output stage and push-pull complementary circuitry in the driver stage, completely eliminating the distortion inherent transformers from the audio stage.

### **EASY-TO-OPERATE STYLISH PANEL DESIGN**

Easy-to-operate configuration of controls and switches on the front panel plus styling of lasting beauty is an additional feature.

### **COMPLETE PROVISION OF AUXILIARY CIRCUITS**

The auxiliary circuits include the tone control, loudness contour, tape monitor, headphones jack, etc. With these circuits, you can have a full command over reproduction of sounds to obtain every advantage of the most advanced audio technology.

# FUNCTIONS OF THE FRONT PANEL CONTROLS AND INDICATORS

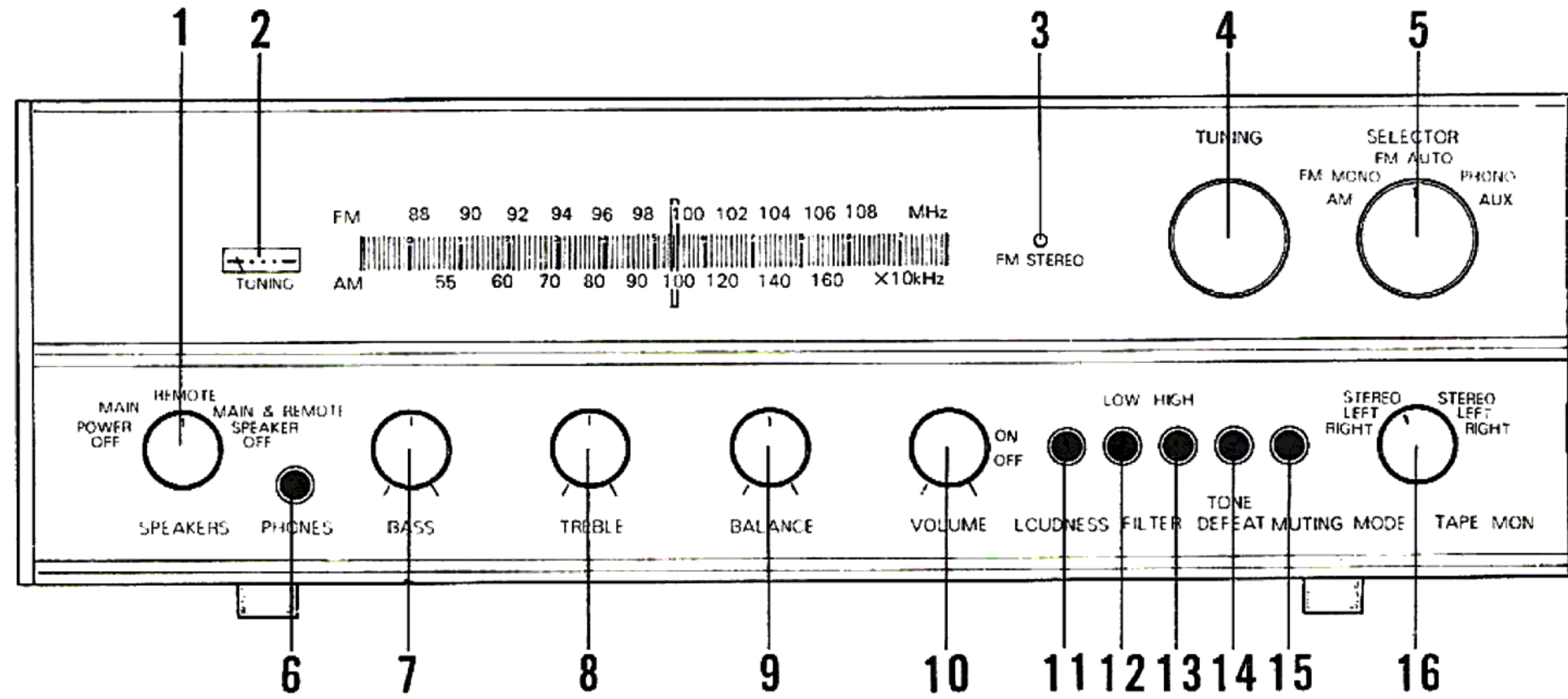

Fig. 1

## 1. SPEAKERS SWITCH

A combination of the power on-off switch and the loudspeaker system selector switch.

- |                     |  |
|---------------------|--|
| POWER OFF .....     | The equipment is dead.<br>The power supplied from the SWITCHED AC outlet (32) is discontinued simultaneously.  |
| MAIN .....          | For listening through main loudspeakers.   |
| REMOTE .....        | For listening through remote loudspeakers.   |
| MAIN + REMOTE ..... | For listening through both main and remote loudspeakers.   |
| SPEAKER OFF .....   | By setting this switch to the OFF position and listening through a pair of stereo headphones, it will be possible to enjoy reproduction of program material in complete privacy. |

## 2. TUNING INDICATOR

This meter indicates the optimum tuning points for stations. The point of maximum swing for any station is the tuning point for that station.

## 3. FM STEREO INDICATOR

This indicator light automatically switches on when the FM station being received is a stereo.

NOTE: With the SELECTOR (5) set to the FM-AUTO position, even if the broadcast being received is a stereo broadcast, there may be times when the indicator light may not go on, in such cases, the signal will be reproduced as a monophonic broadcast.

## 4. TUNING

This control tunes the receiver to the desired AM, FM, or FM STEREO station.

## 5. SELECTOR

This control switch selects the program material to be reproduced, the type of radio broadcast, phono or audio signal from a TV set.

Its positions are as follows:

- |               |  |
|---------------|--|
| AM .....      | For reception of AM Stations.  |
| FM-MONO ..... | For reception of FM Monophonic Stations.   |
| FM-AUTO ..... | For reception of FM broadcasts, with automatic switching between FM Monophonic and stereo. |
| PHONO .....   | For playback of records.   |
| AUX .....     | For reproduction of auxiliary signals fed to the AUX position.                             |

## **6. HEADPHONES JACK**

This jack is for stereo headphones. It remains live at all times.

## **7. BASS CONTROL**

This control adjusts bass response. Turning it clockwise will boost, and turning it counterclockwise will reduce bass response. If the two-section control, the front section adjusts the left channel and the rear section adjusts the right channel.

## **8. TREBLE CONTROL**

This control adjusts treble response. Turning it clockwise will boost, and turning it counterclockwise will reduce treble response. If the two-section control, the front section adjusts the left channel and the rear section adjusts the right channel.

## **9. BALANCE CONTROL**

This control serves to balance the volume level of the left and right channels. Turning it to the right (clockwise) will increase the sound in the right channel. Turning it to the left (counterclockwise) will increase the left channel.

## **10. VOLUME CONTROL**

This control adjusts the volume level. Turning it to the right will increase the volume and turning it to the left will lower the volume.

## **11. LOUDNESS CONTOUR**

At low sound levels, the sensitivity of the human ear to low and high frequencies deteriorates. The function of the LOUDNESS CONTOUR circuit is to compensate for this deficiency in the extreme bass and treble range. For listening at low volume settings, set this switch to the ON position.

## **12. LOW FILTER**

Use this filter to cut out low-frequency interference, such as motor rumbling or hum.

## **13. HIGH FILTER**

Use this filter to cut out high-frequency interference, such as that from fluorescent light.

## **14. TONE DEFEAT**

This switch when in the ON position de-activates the Bass and Treble Controls:

You now have a perfectly flat frequency response. If you desire more Bass or Treble sound reproduction, leave this switch in "OFF" position, and set the Bass and Treble controls to the desired positions.

## **15. MUTING**

This switch is used to suppress noise between FM stations when tuning. In a fringe area, however, this switch should be kept off because it may suppress the desired station signal at the same time.

## **16. MODE/TAPE MONITOR SWITCH**

This switch is the selector for stereo/mono and tape monitor settings.

Positions are as follows:

MODE-RIGHT . . . . .	For reproduction through both left and right loudspeakers of program material being fed to any of the right channel inputs.
MODE-LEFT . . . . .	For reproduction through both left and right loudspeakers of program material being fed to any of the left channel inputs.
MODE-STEREO . . . . .	For stereo reproduction.
TAPE-MON-STEREO . . . . .	For stereo reproduction of program material fed to the TAPE-MONITOR inputs (26).
TAPE MON-LEFT . . . . .	For reproduction through both left and right loudspeakers of program material being fed to the left channel TAPE MONITOR input.
TAPE MON-RIGHT . . . . .	For reproduction through both left and right loudspeakers of program material being fed to the right channel TAPE MONITOR input.

# FUNCTIONS OF THE REAR PANEL CONTROL, TERMINALS AND INPUTS

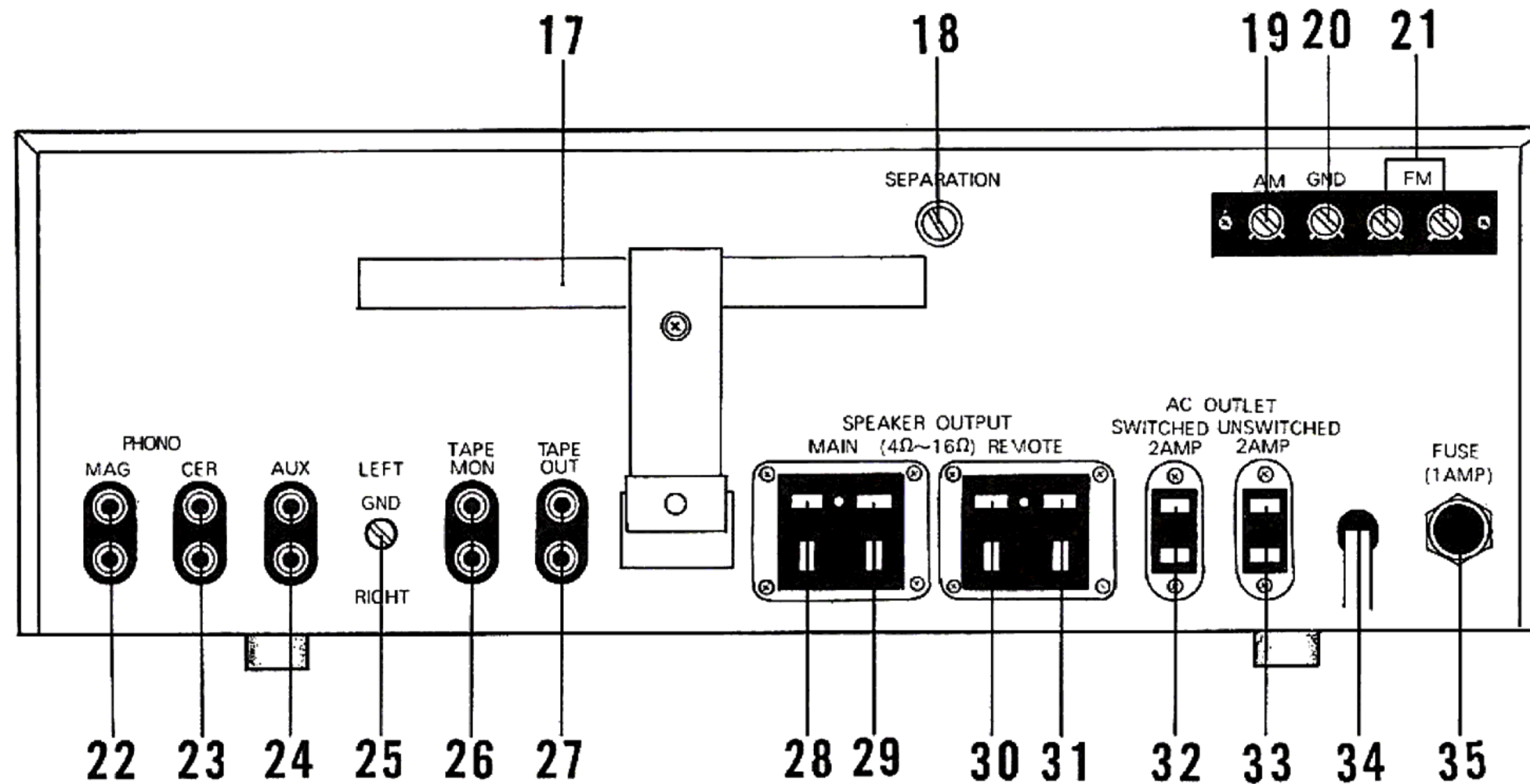

Fig. 2

## 17. AM FERRITE LOOPSTICK ANTENNA

This is a loopstick antenna for the reception of AM stations. In areas relatively close to the AM station, this antenna will provide satisfactory reception. This antenna has directional properties, so it should be moved about while listening to a station and set at the position providing best reception.

## 18. MPX SEPARATION CONTROL

This control adjusts the channel separation of FM multiplex stereo broadcasts. It has already been adjusted at the factory, and normally there should be no need for any further adjustment.

## 19. AM ANTENNA TERMINAL

This is the terminal for the AM antenna. The lead cable provided may be used as an indoor antenna, or the lead from an outdoor antenna, if you plan to use one.

## 20. GND1

When using a ground lead for the receiver it should be connected to this terminal.

## 21. FM ANTENNA TERMINALS

These are the terminals for the FM antenna. The leads from the indoor T-shaped antenna or the leads from an outdoor antenna, should be connected to these terminals.

## 22. PHONO MAG

When using a turntable that is equipped with a magnetic cartridge, the output cables should be connected to these input jacks.

## 23. PHONO CER/XTAL

When using a turntable that is equipped with a ceramic or crystal cartridge, the output cables should be connected to these input jacks.

## **24. AUX INPUT JACKS**

These are input jacks for auxiliary inputs, such as the audio signal from a TV set.

## **25. GND 2**

If a turntable equipped with a ground lead is used, then it should also be connected to this terminal.

## **26. TAPE MONITOR INPUT JACKS**

When playing back tape recordings using a tape deck equipped with preamplifiers, the LINE OUTPUT of the tape recorder should be connected to these input jacks.

## **27. TAPE OUTPUT JACKS**

To make tape recordings of program material, the LINE INPUT of the tape recorder are connected to these recording output jacks.

## **28 & 29 MAIN LOUDSPEAKER TERMINALS**

The Allied 490 is designed to permit connection of two sets of stereo loudspeaker systems. Connect the first set of loudspeaker system (MAIN system) to these terminals; the right channel to terminal (28) and the left channel loudspeaker of this system to terminal (29).

## **30 & 31 REMOTE LOUDSPEAKER TERMINALS**

Connect the right channel loudspeaker of the second loudspeaker system (REMOTE system) to terminal (30) and the left channel loudspeaker of this system to terminal (31).

## **32. AC OUTLET (SWITCHED)**

This is AC outlet that may be used to provide AC power. This one has a maximum capacity of 230 W, and is controlled through the POWER SWITCH (1).

## **33. AC OUTLET (UNSWITCHED)**

This is another AC outlet that provides a convenient source of power for your turntable, tape deck or recorder. It has a maximum capacity of 230 W. It is not controlled through the POWER SWITCH (1), and remains live at all times.

## **34. AC CORD**

This is the AC power cord.

## **35. FUSE**

This is the fuse holder. If it is necessary to replace the fuse, always use glass-tube fuse. Use a 1-ampere fuse only.

# ANTENNA AND GROUND CONNECTIONS

## AM ANTENNA

The FERRITE LOOPSTICK ANTENNA (17) mounted on the rear of the receiver will provide satisfactory reception of local stations with strong signals. Because the loopstick antenna has directional properties, its direction may be adjusted for the best reception while listening to a station.

If noise is strong in your area and the adjustment of the loopstick antenna direction does not improve the situation, the furnished AM lead antenna may be laid on the wall or on other standing object as high as possible, and one end of the antenna lead should be connected to the AM ANTENNA TERMINAL (19). If the furnished antenna does not help, an outdoor AM antenna may need to be set up. In this case, the antenna lead should also be connected to the AM ANTENNA TERMINAL (19).

## FM ANTENNA

If the receiver is situated in regions close to the transmitting site or is placed in a wooden building, the furnished simple indoor T-shaped antenna will provide satisfactory results. In this case, the two wires of the twin lead from the antenna should be connected to the FM ANTENNA TERMINALS (21) and the horizontal element of the T-section should be extended and positioned for the best reception while listening to an FM station. Then, the antenna should be secured to the wall or to any support.

In regions where the furnished indoor T-shaped antenna provided poor results such as many noises or poor separation, an outdoor FM antenna may be required. In this case the leads from the outdoor antenna should also be connected to the FM ANTENNA TERMINALS (21).

## GROUND

In some area, the use of a proper ground reduces noise significantly. The lead from an appropriate grounding electrode such as a water pipe or a ground rod, is connected to GROUND TERMINAL (20).

# LOUDSPEAKER CONNECTIONS

Two loudspeaker systems, the main and remote, the left and right channel loudspeakers per system or four loudspeakers in total may be connected to the receiver. Note, however, that the impedance of each channel loudspeaker must be larger than four ohms when two loudspeaker system are connected to the receiver. As shown in Fig. 3, the loudspeaker leads are connected to the speaker plug furnished with this receiver. In this case, be sure that the positive loudspeaker lead is connected to the positive terminal on the plug with reference to Fig. 3.

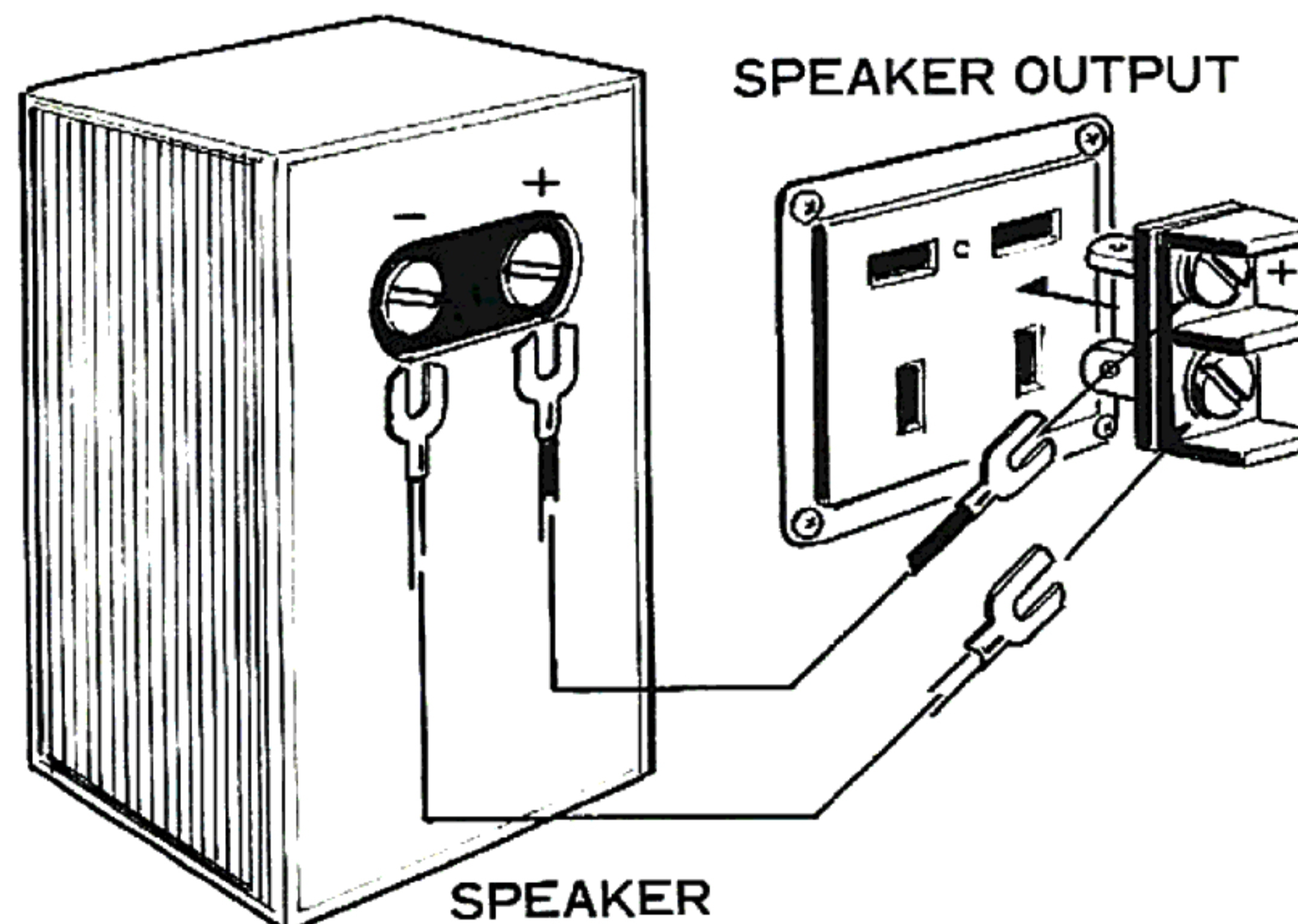

Fig. 3

## **CONNECTION FOR INSTALLATION OF ONE LOUDSPEAKER SYSTEM**

1. The speaker plug connected to the leads from the right channel loudspeaker is inserted into its mating socket [MAIN SPEAKER TERMINALS-RIGHT CHANNEL (28)].
2. The speaker plug connected to the leads from the left channel loudspeaker is inserted into its mating socket [MAIN SPEAKER TERMINALS-LEFT CHANNEL (29)].

## **CONNECTION FOR INSTALLATION OF TWO LOUDSPEAKER SYSTEMS**

1. The first loudspeaker system is connected to the MAIN SPEAKER TERMINALS (28) and (29) as described in the preceding paragraph.
2. The second loudspeaker system is connected to the REMOTE SPEAKER TERMINALS (30) and (31) in the similar manner described in the preceding paragraph: the right channel loudspeaker is connected to the terminals (30) and the left channel loudspeaker to the terminals (31).

NOTE: If only one loudspeaker system is connected to either of the two sets of LOUDSPEAKER output terminals, the loudspeaker impedance (each channel) may be 4 to 16 ohms. If, however, both output terminals (MAIN SPEAKER and REMOTE SPEAKER) are used for connection with two loudspeaker system, the loudspeaker impedance (each channel) should be 8 to 16 ohms.

## **TURNTABLE CONNECTIONS**

Any type of turntables or record changers with a ceramic, or magnetic type cartridge may be used. However, for best tonal quality, a turntable using a magnetic type cartridge, is recommended.

### **MAGNETIC PICKUP TURNTABLE CONNECTIONS**

1. When using a turntable equipped with a magnetic type cartridge, the output leads should be connected to the PHONO MAG inputs (22).

### **CERAMIC/CRYSTAL PICKUP TURNTABLE CONNECTIONS**

1. When using a turntable equipped with either a ceramic or crystal cartridge, the output leads are to be connected to the CER/XTAL inputs (23).

The upper of the two terminals for the left channel and lower is for the right channel.

When using a monophonic turntable, it does not matter which of the two inputs the output cable is connected to, as long as the MODE/TAPE MONITOR SWITCH (15) is switched to the corresponding "MODE-LEFT" or "MODE-RIGHT" position.

## **TAPE RECORDER CONNECTIONS**

### **FOR PLAYBACK**

- \* Connect the LINE OUTPUT (either the output jacks or monitor jacks) of your tape recorder to the TAPE MONITOR INPUT JACKS (26).

### **FOR RECORDING**

- \* Connect the LINE INPUT (the recorder's input jacks) of your tape recorder to the TAPE OUTPUT JACKS (27).

NOTE: In the TAPE MONITOR INPUT JACKS (26) and TAPE OUTPUT JACKS (27), the upper jack is for the left channel and the lower jack is for the right channel. If your tape recorder is mono type, connect the recorder's input jack to the upper output jack of the TAPE OUTPUT JACKS (27) and set the MODE/TAPE MONITOR SWITCH (15) to MODE-MONO.

## RECEPTION OF FM BROADCASTS

1. Whether you plan to listen to FM-monophonic or FM stereo broadcasts, first set the SELECTOR (5) to the FM-AUTO position, and the set MODE/TAPE MONITOR (15) to the MODE-STEREO.

The MODEL 490 is equipped with an FM mono/stereo automatic switching circuit which serves to identify an FM signal automatically as either a mono or a stereo signal.

Monophonic signals are reproduced in mono, and stereo signals are automatically reproduced in stereo. When a stereo signal is received and reproduced, the stereo indicator light will go on.

2. Tune in the desired station with the TUNING CONTROL (4) while observing the TUNING INDICATOR for pinpoint accuracy in tuning.

- NOTES:
1. With the SELECTOR (5) set to the FM-AUTO position, if an extremely weak stereo broadcast is received and there is excessive noise, the receiver will automatically switch to mono operation.
  2. If you wish to reproduce FM-stereo broadcasts in mono, or if there is excessive noise with the SELECTOR (5) set to the FM-AUTO position and tonal quality is impaired, set the SELECTOR (5) to the FM-MONO position. The MODE/TAPE MONITOR SWITCH (16) may be set to the MODE-STEREO, MODE-LEFT or MODE-RIGHT positions.

## RECEPTION OF AM BROADCASTS

1. The SELECTOR (5) is set to the AM position. The MODE/TAPE MONITOR SWITCH may be set to the MODE-STEREO, MODE-LEFT, or MODE-RIGHT positions.
2. The desired station is tuned in by means of the tuning control (4) while observing the TUNING INDICATOR (2).

## RECORD REPRODUCTION

1. The SELECTOR (5) is set to the PHONO position.
2. The MODE/TAPE MONITOR SWITCH (15) is now set to the appropriate position. When using a stereo turntable, it should be set to the MODE-STEREO position, and when using a monophonic turntable, it should be set to either the MODE-LEFT or MODE-RIGHT positions, depending upon which channel input the output cable of the turntable is connected to.

# RECORDING AND PLAYBACK USING TAPE

## RECORDING

1. Set the SELECTOR (5) to the position providing reproduction of the program material that is to be recorded: AM, FM-AUTO, or PHONO.

NOTE: 1. When making monophonic recordings by using a monophonic or stereo tape recorder, connect the input of the tape recorder to one of the two TAPE OUT outputs.

2. The setting of the MODE/TAPE MONITOR SWITCH (15), the VOLUME CONTROL (11), the TREBLE CONTROL (9), the BASS CONTROL (8) and the HIGH FILTER (14) do not affect the sounds being recorded. The recording level should be adjusted with the level controls of the tape recorder.

## PLAYBACK

1. For stereo playback, the MODE/TAPE MONITOR SWITCH (15) should be set to the MONITOR-STEREO position. For playback of mono material using a monophonic or stereo tape recorder, the MODE/TAPE MONITOR SWITCH (15) should be set to either the MONITOR-LEFT or MONITOR-RIGHT, depending upon which track the material is recorded on.

## TAPE MONITORING

When using a 2-or 3-head tape recorder equipped with a monitor circuit, by making all connection for recording and playback, it will be possible to monitor the recording in progress by moving the MODE/TAPE MONITOR SWITCH (16) back and forth between the MODE-STEREO/MODE-RIGHT/MODE-LEFT and MONITOR-STEREO/MONITOR-RIGHT/MONITOR-LEFT positions. In the case of a 2-head tape recorder, the signal being fed to the recording head will be monitored, and in the case of a 3-head tape recorder, the signals recorded on the tape will immediately be monitored by the playback head picking up the recorded signals.

# SCHEMATIC DIAGRAMS & PRINTED CIRCUIT BOARDS

## FM FRONT-END (W11-028)

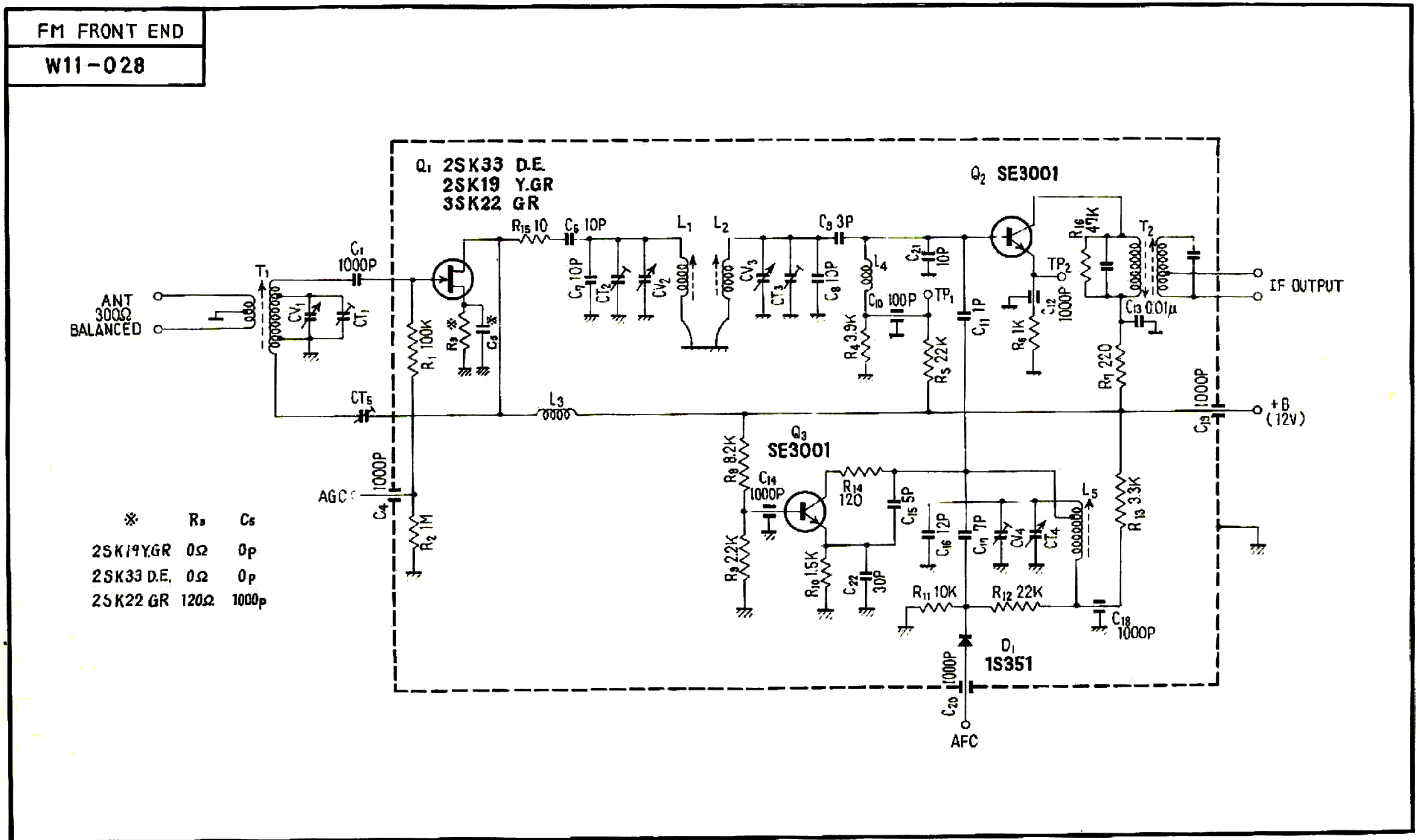

# FM IF UNIT (W12-020)

FM IF UNIT

W12-020

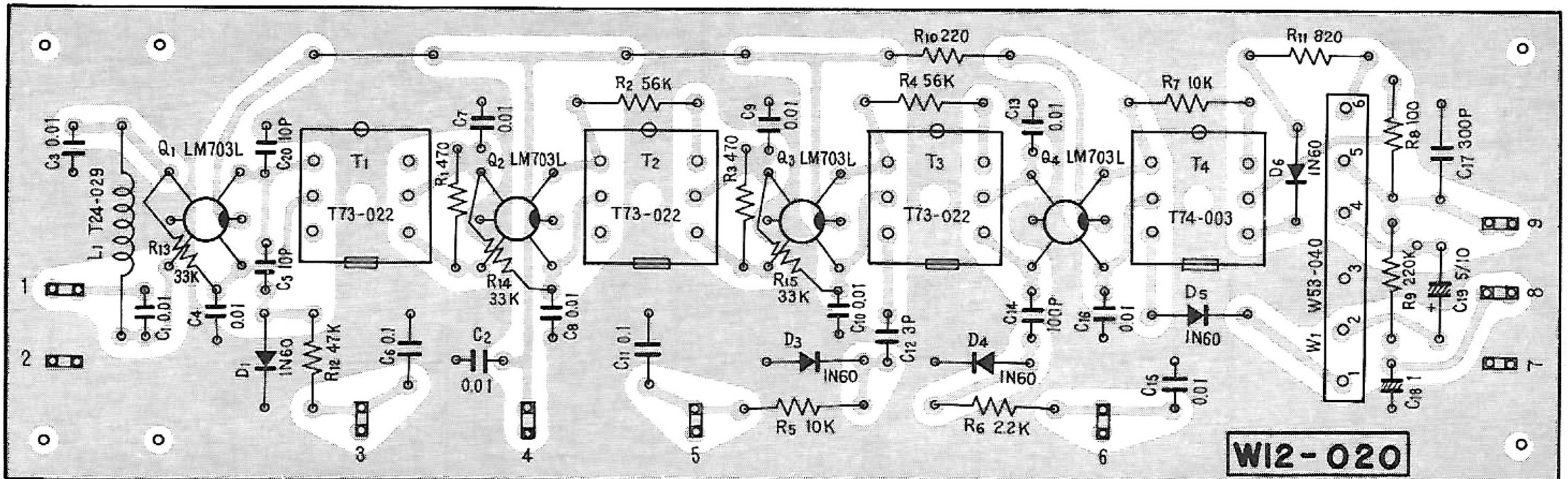
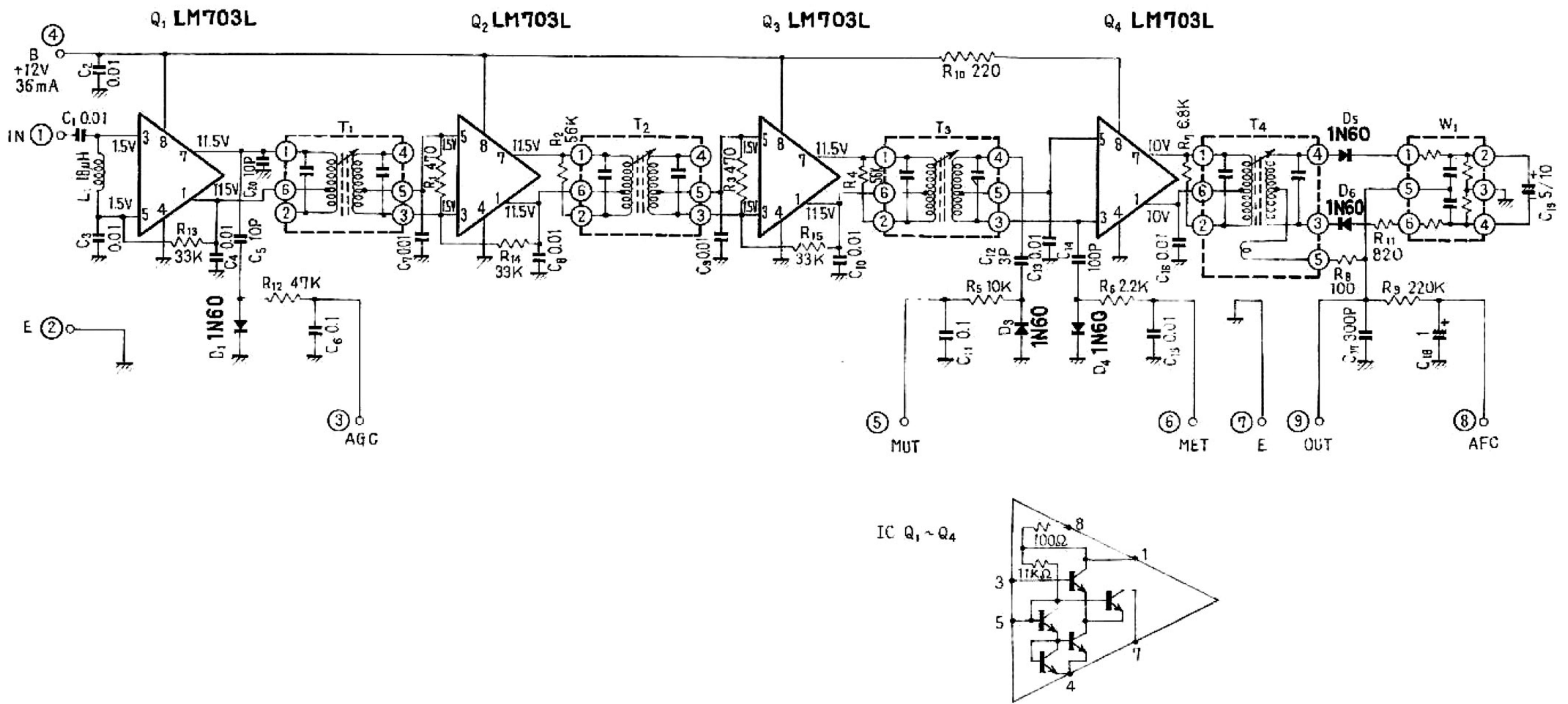



# FM MPX UNIT (W13-021)

MPX UNIT

W13-021

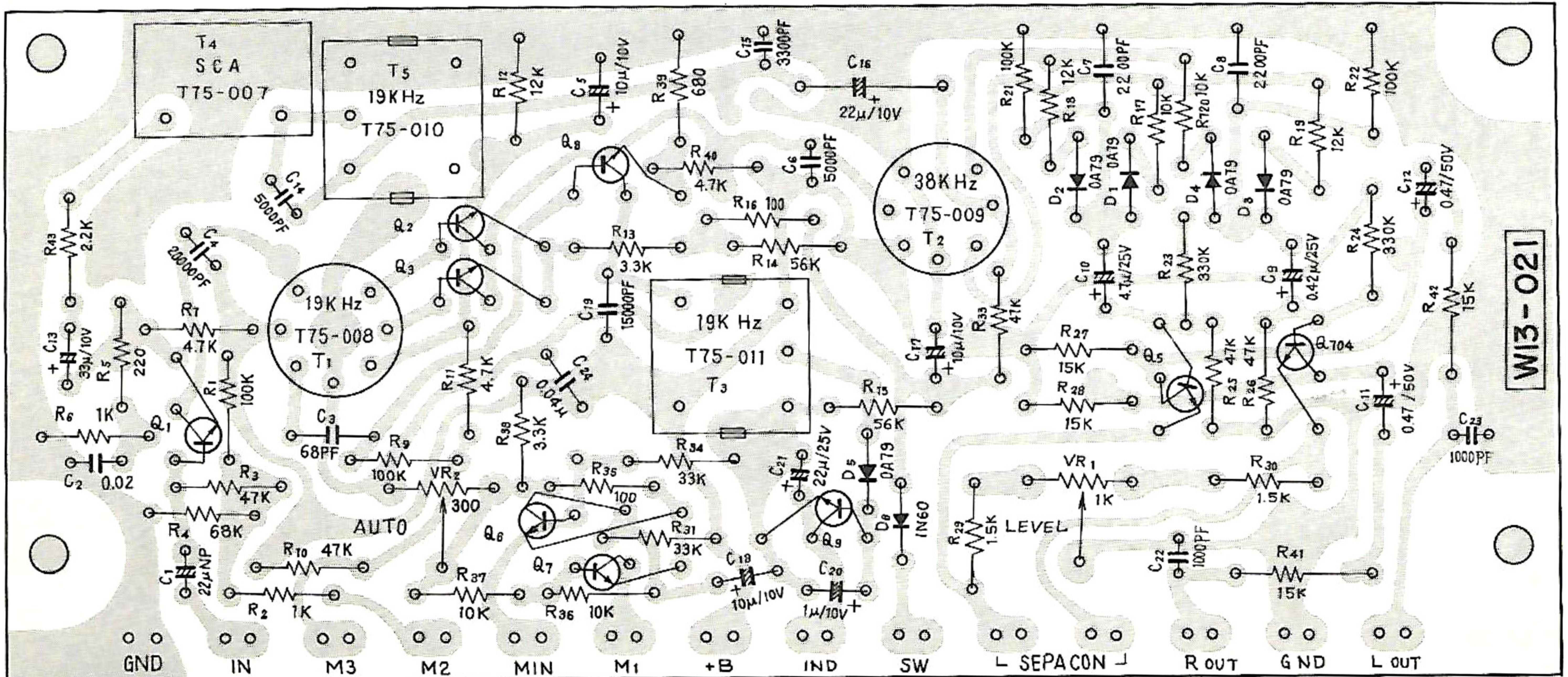
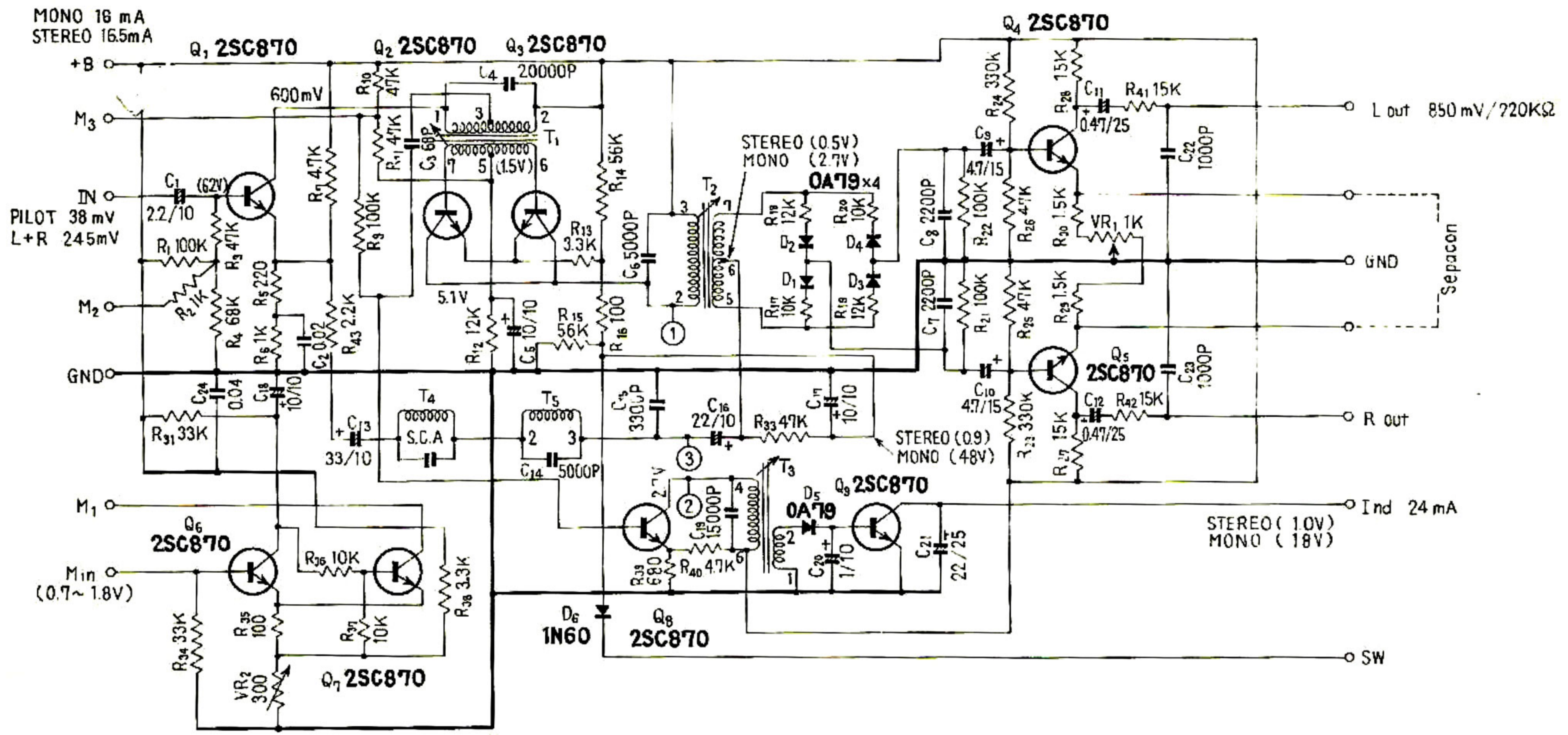

All Transistors are 2SC870

# AM TUNER UNIT (W14-008)

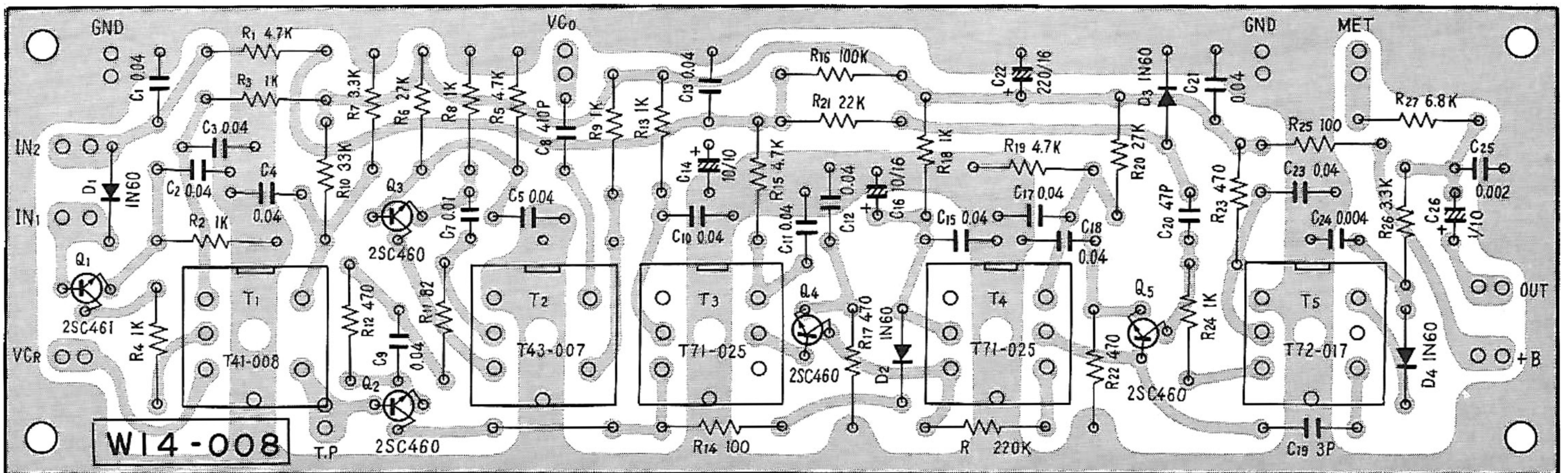
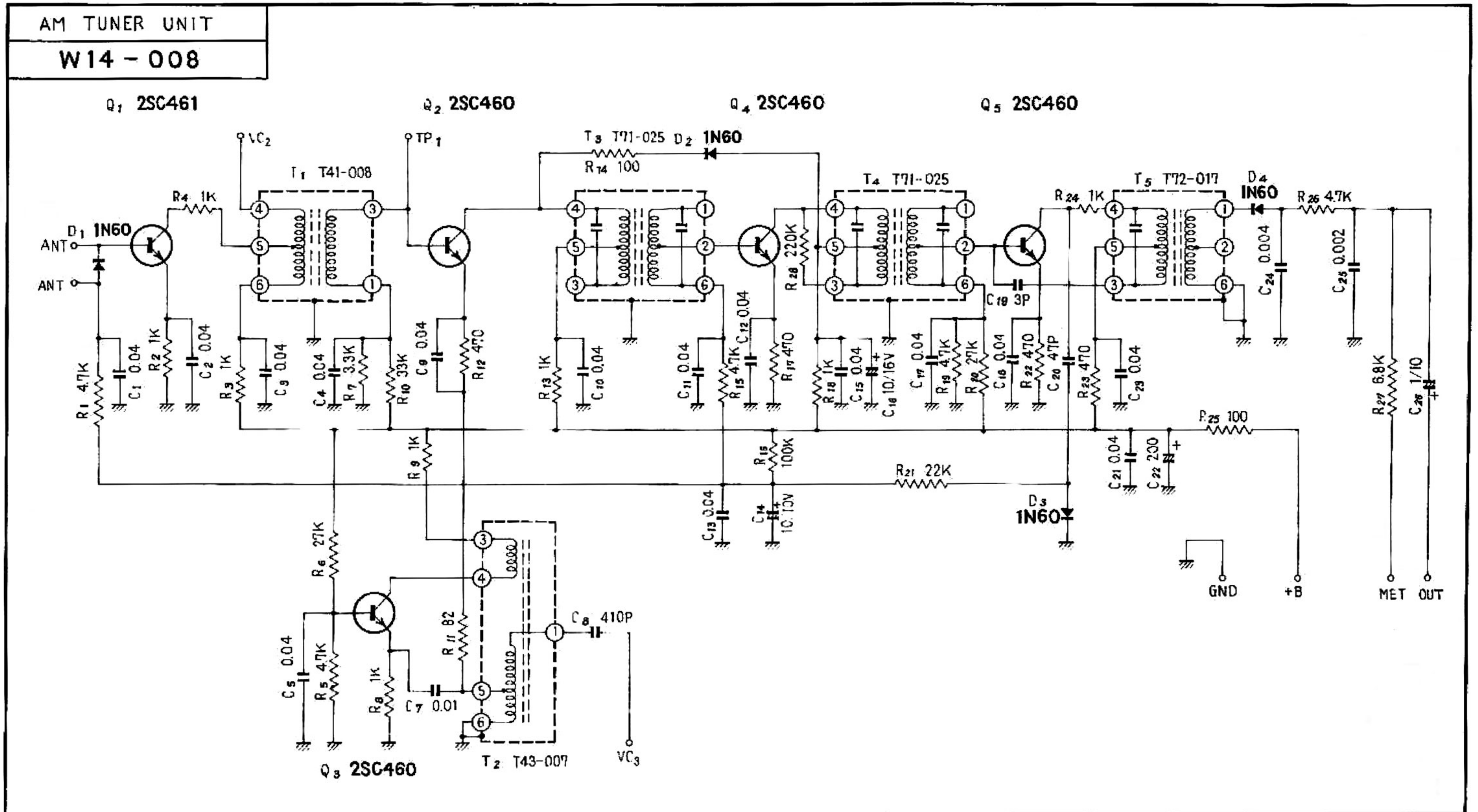

# HEAD AMP UNIT (W15-089)

HEAD AMP UNIT

W15-089

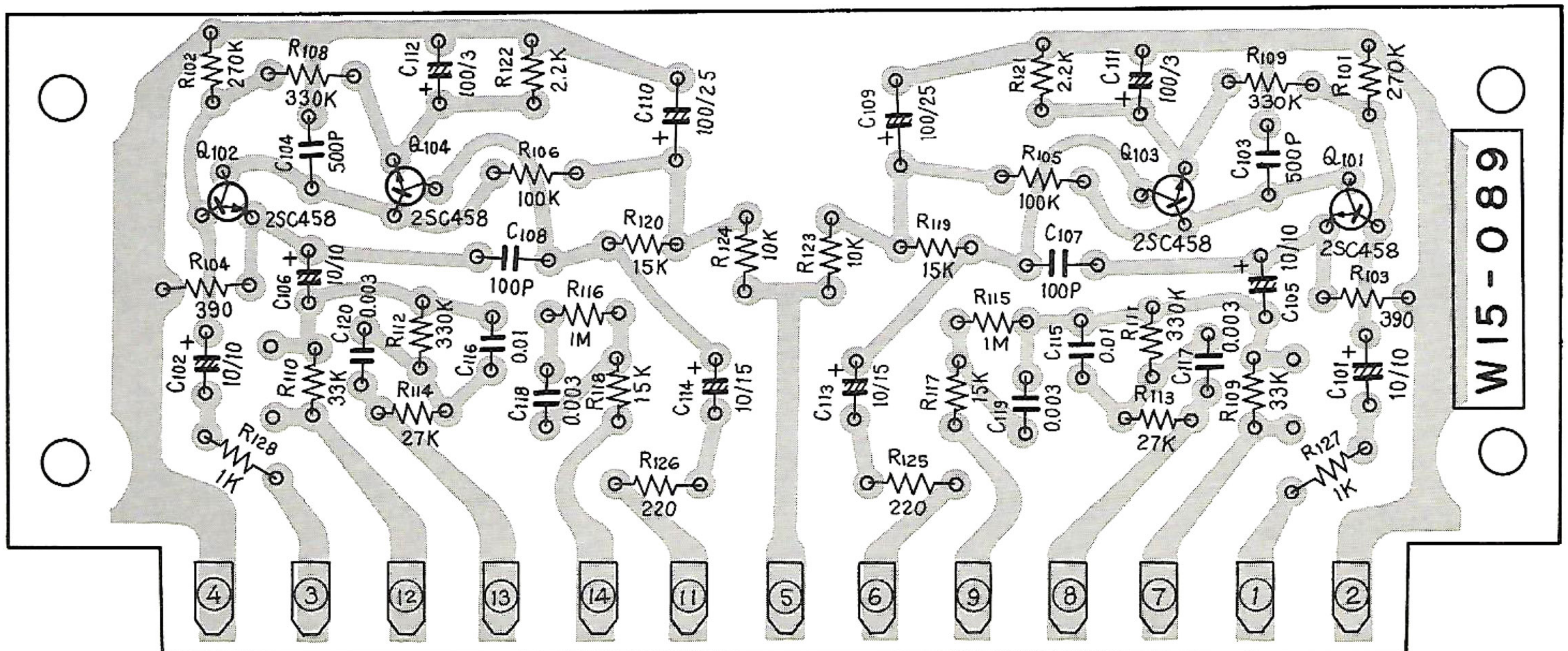
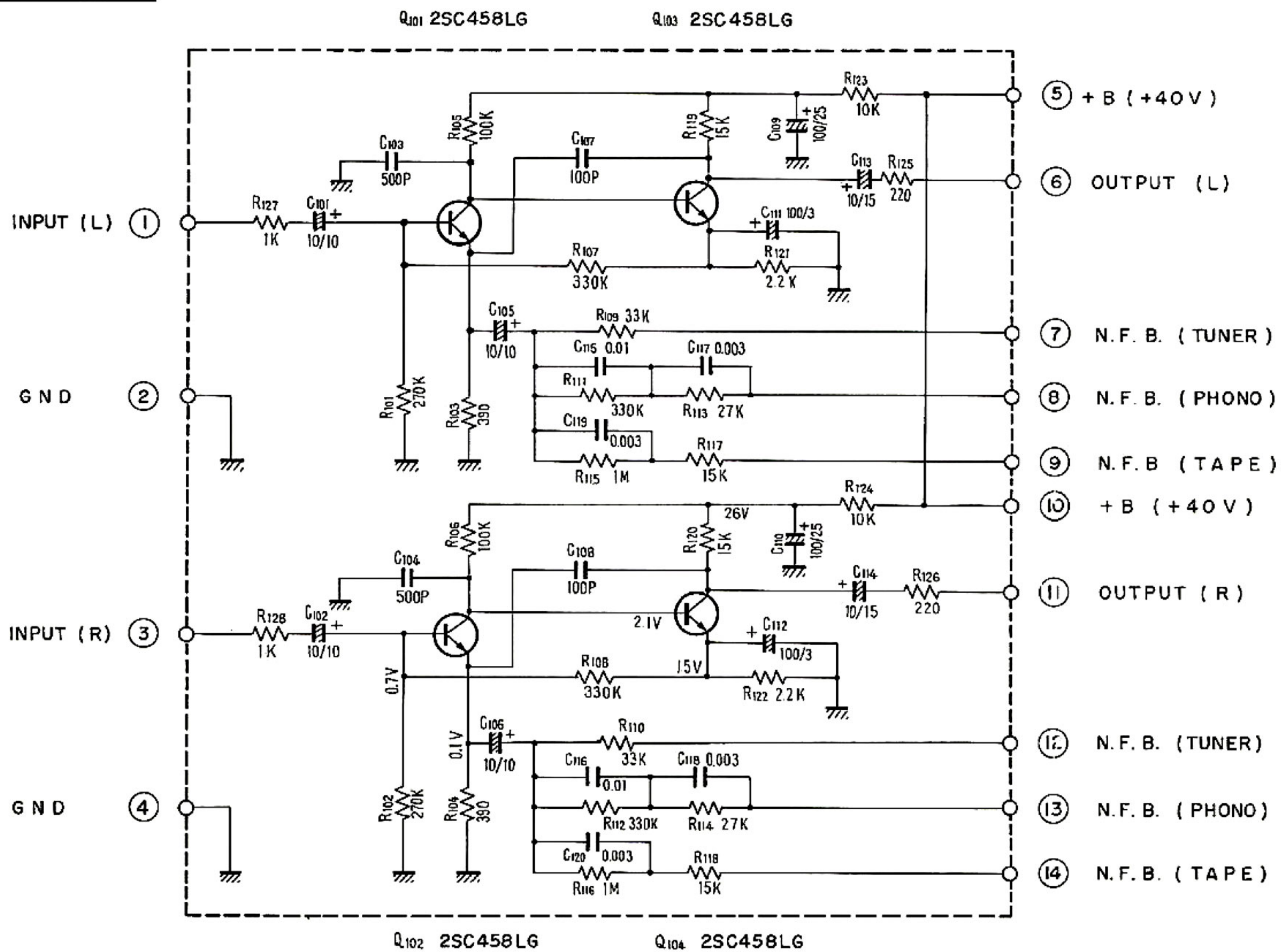

# SWITCH UNIT (W26-009)

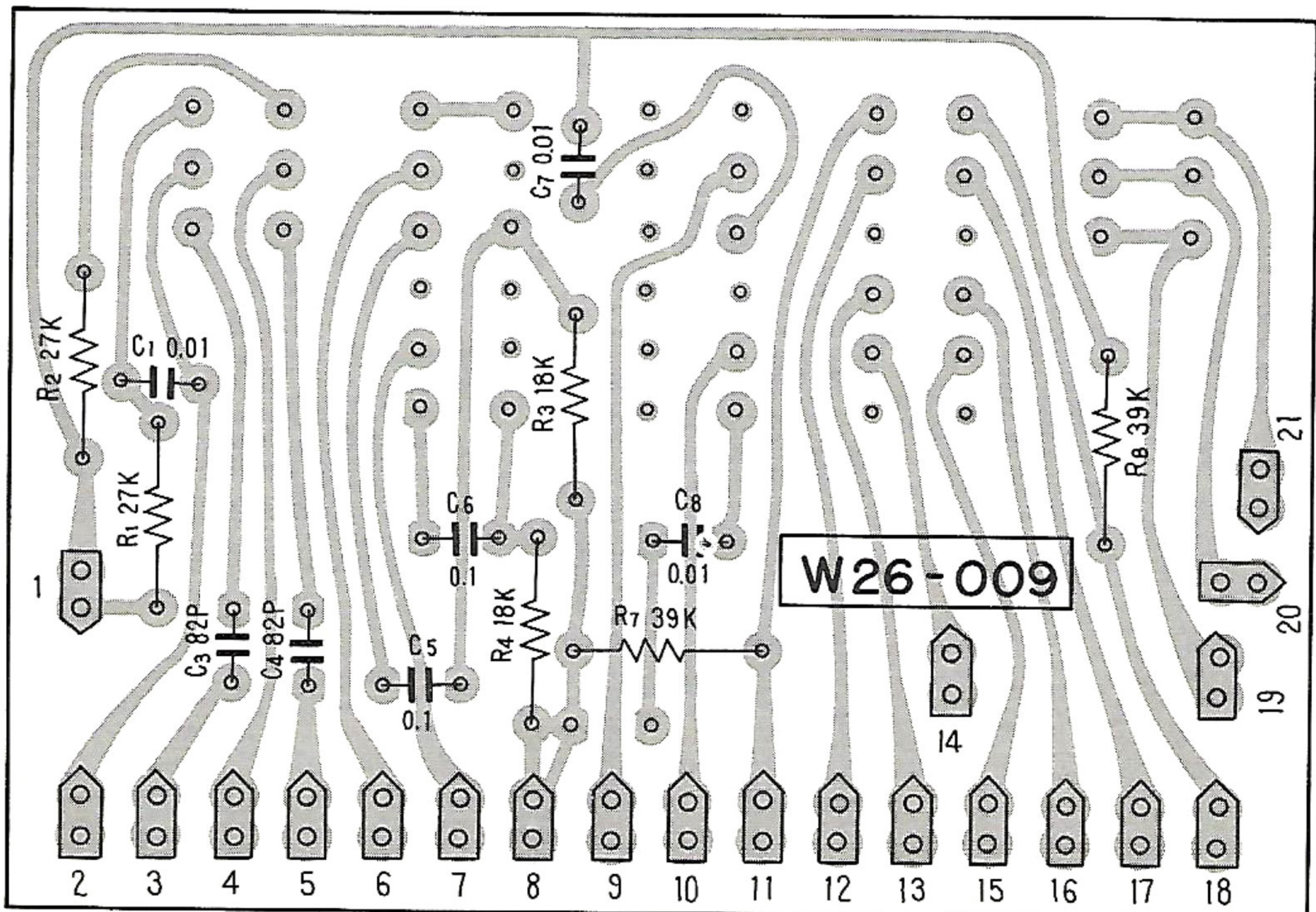
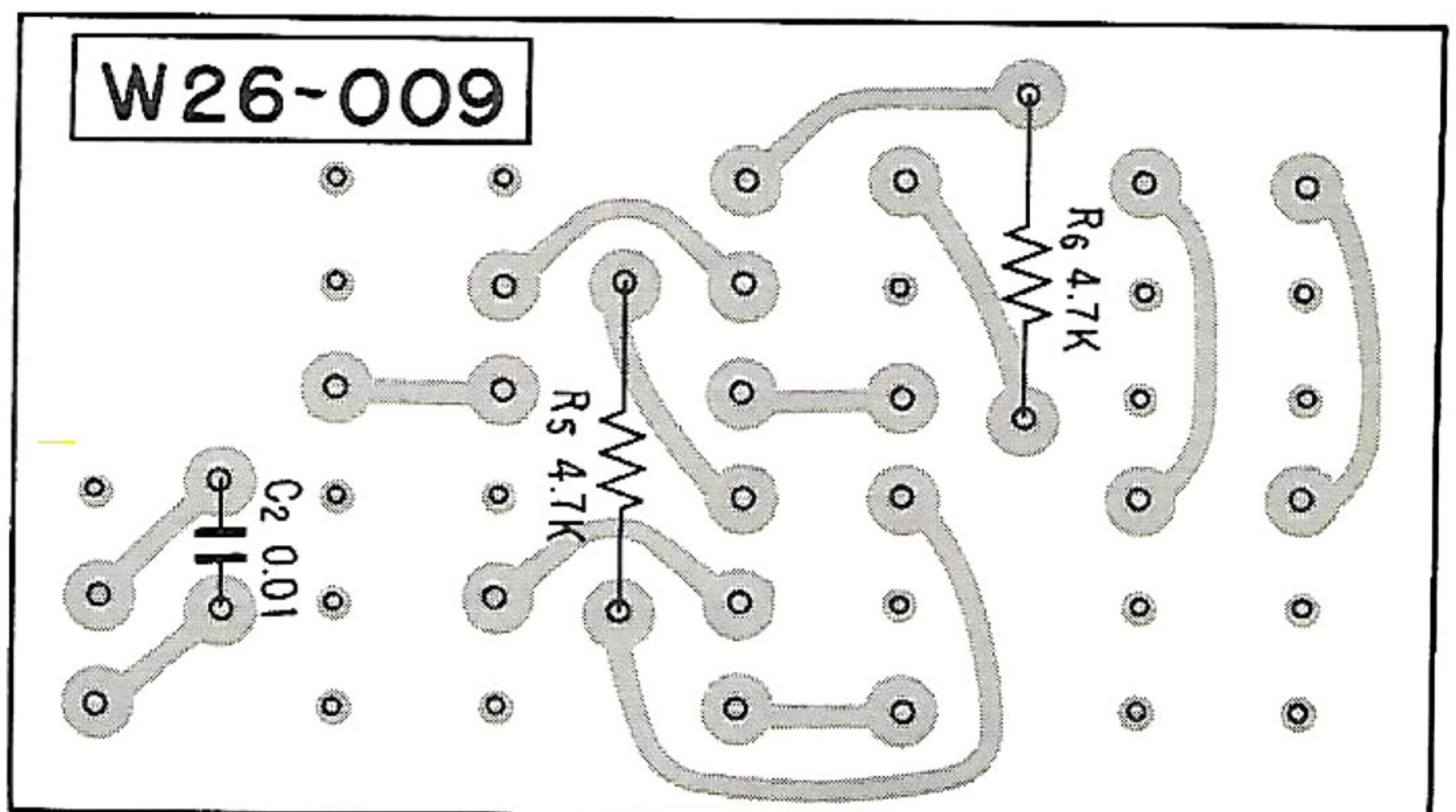
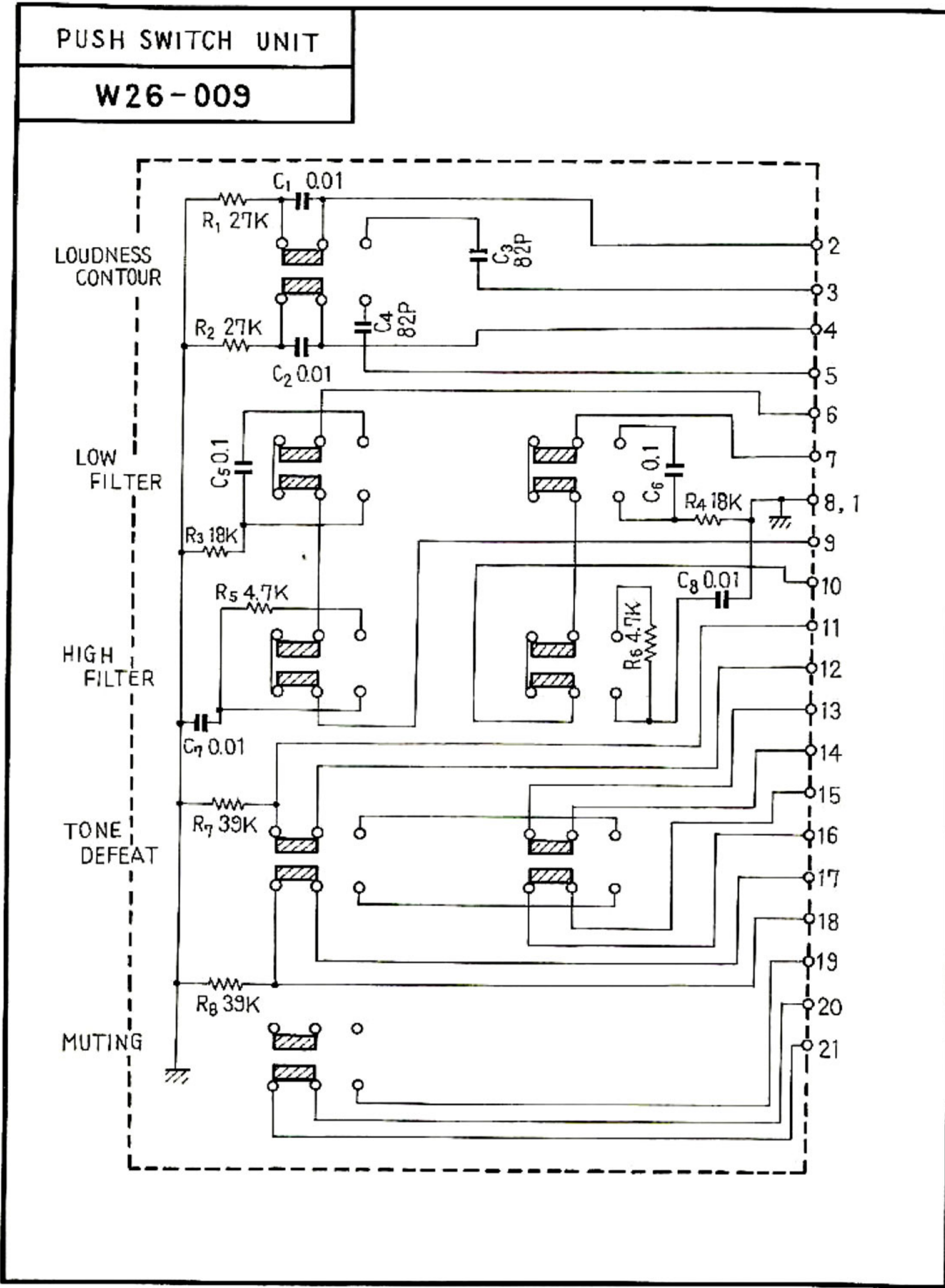

# CONTROL AMP UNIT (W22-004)

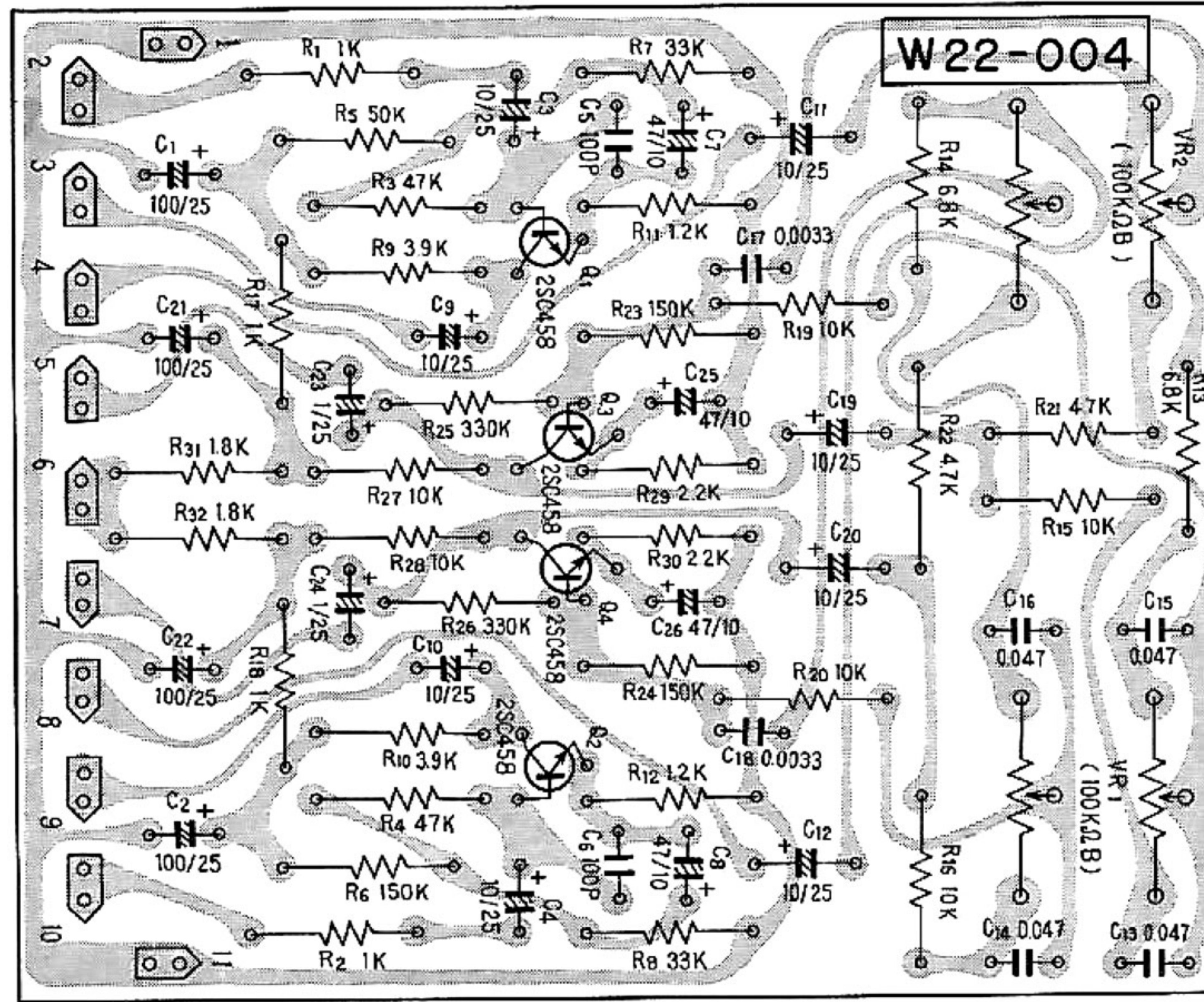
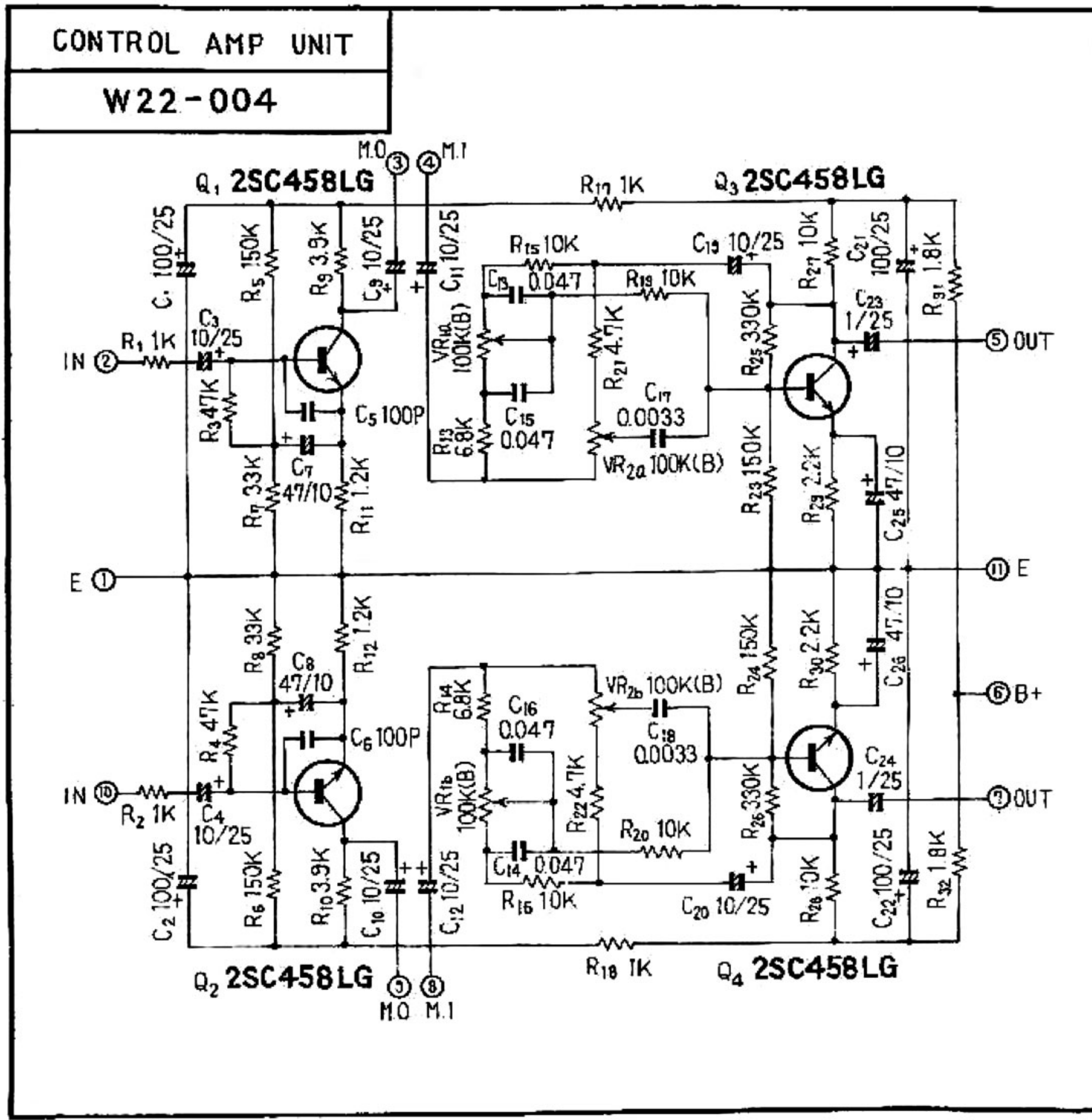

# MAIN AMP UNIT (W15-046)

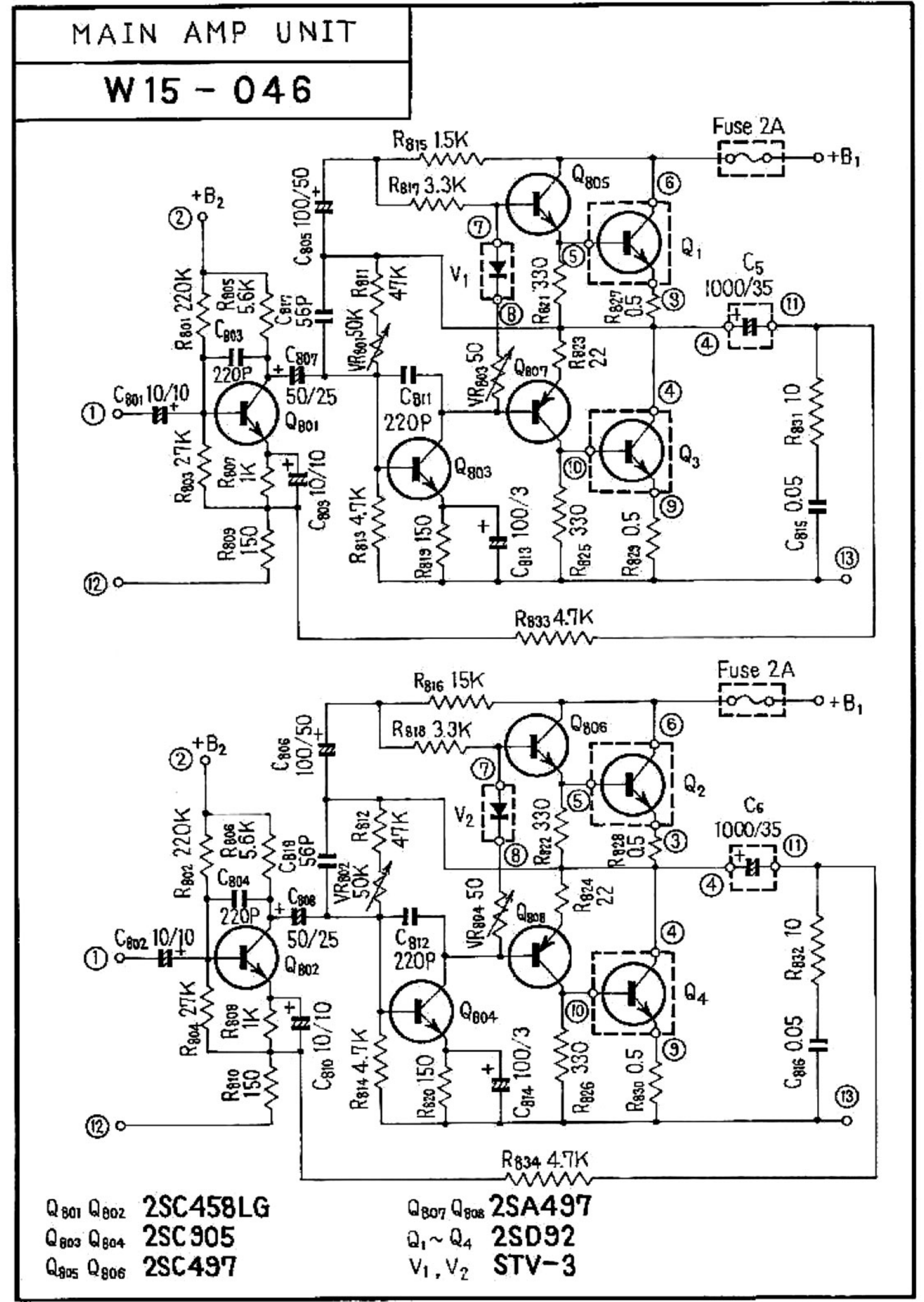

- Q801 Q802 2SC458LG
- Q803 Q804 2SC905
- Q805 Q806 2SC497
- Q1 ~ Q4 2SD92
- V1, V2 STV-3

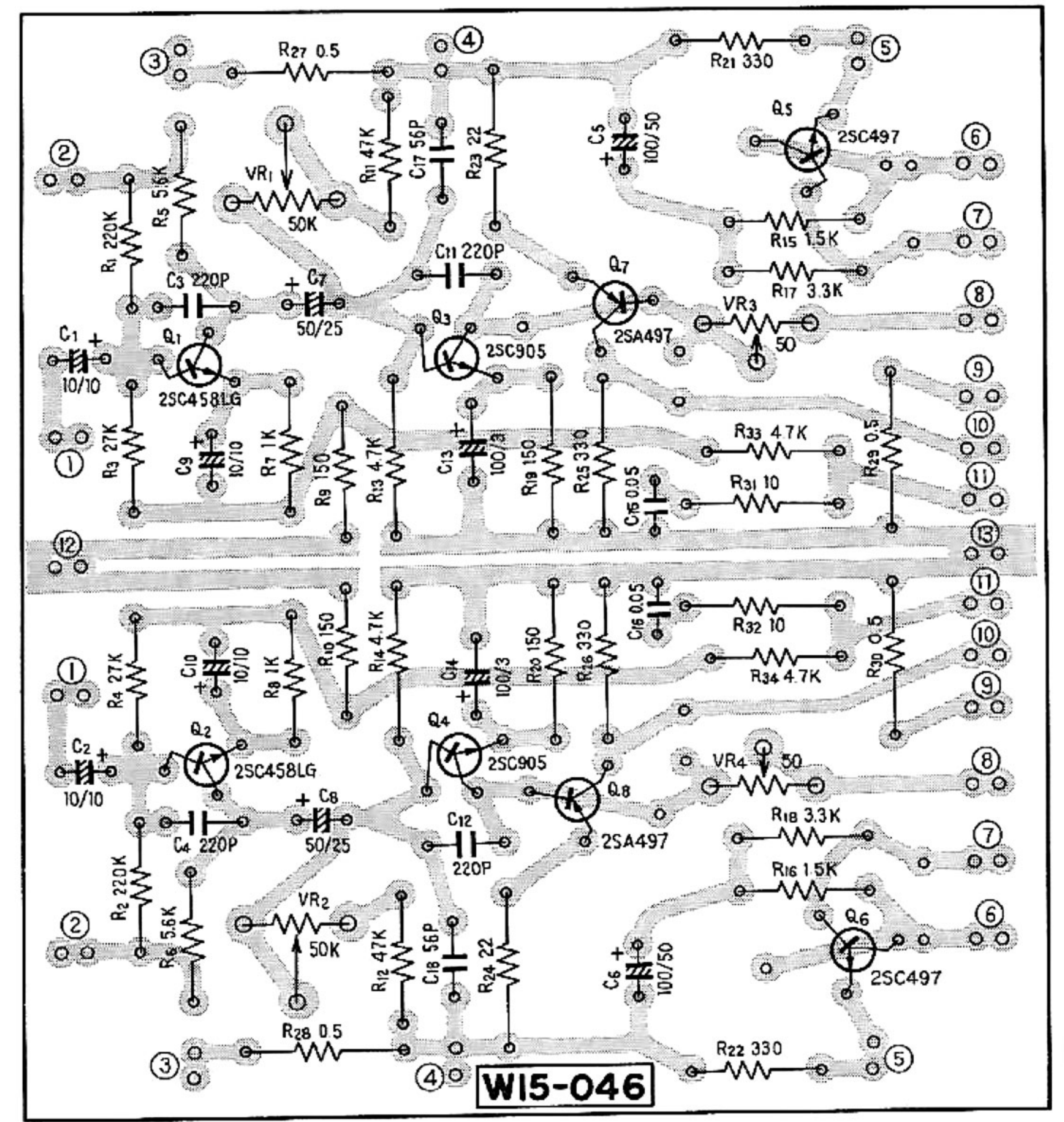

# POWER SUPPLY UNIT (W16-013)

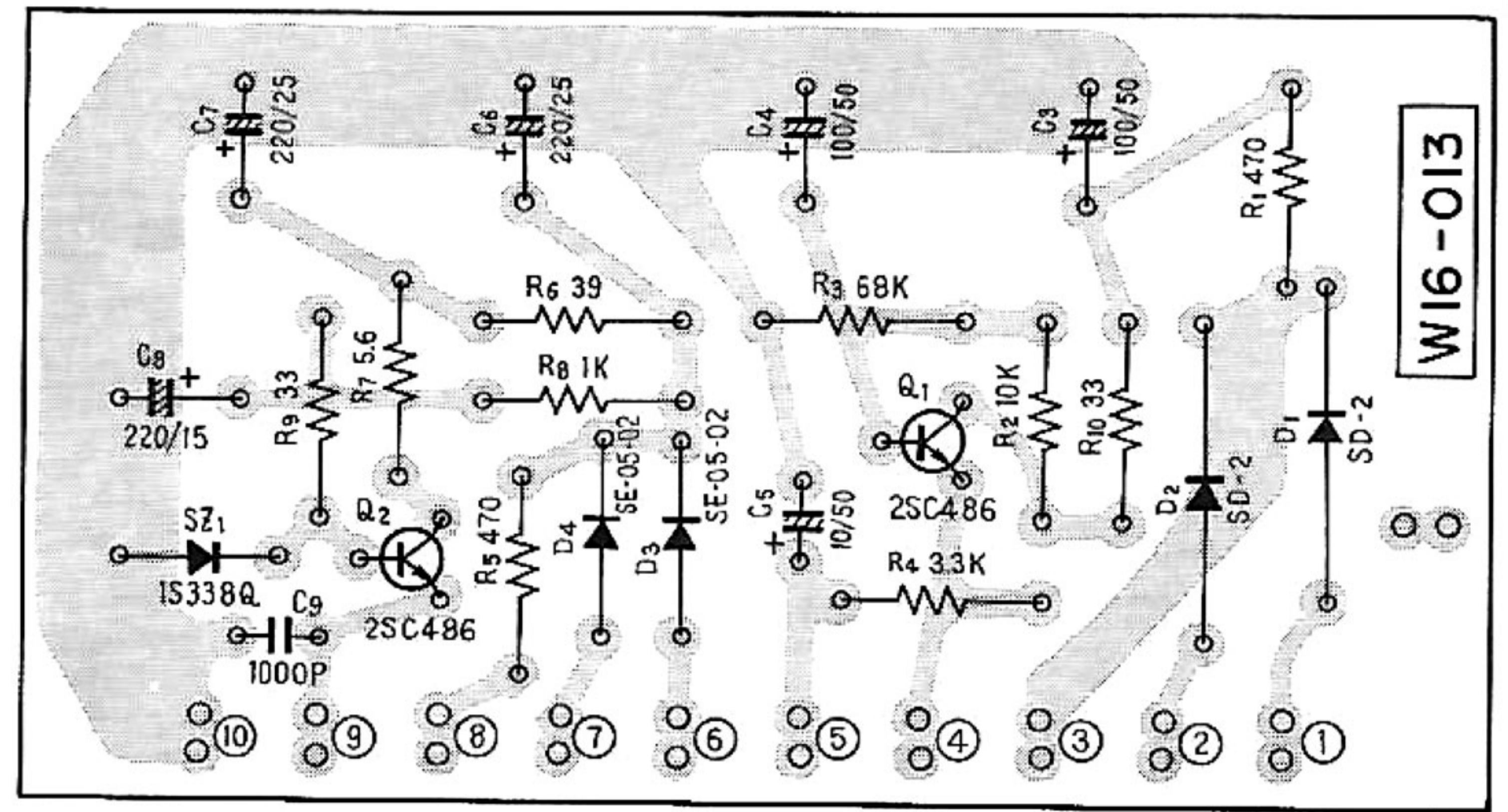
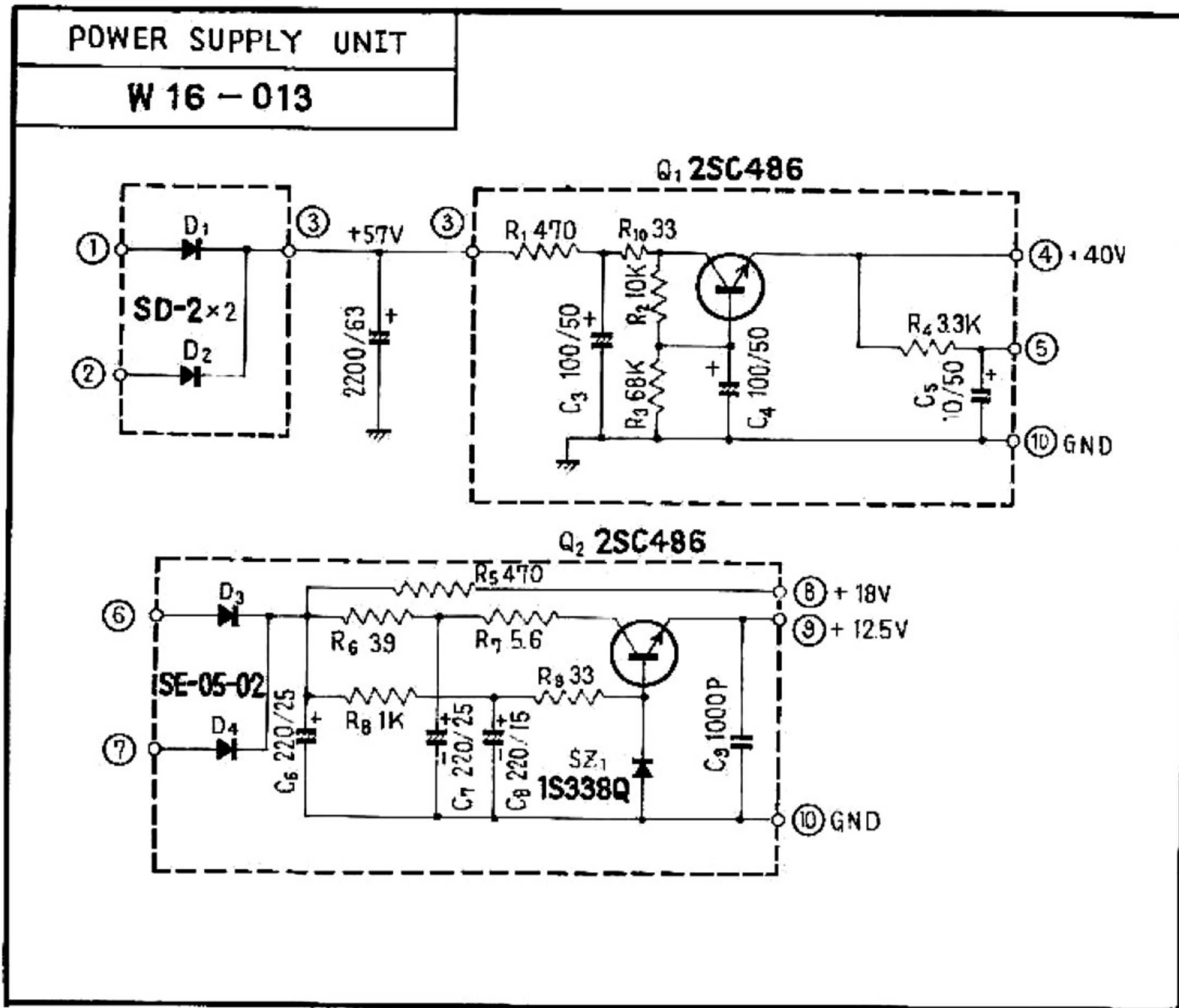

# DIAL CORD STRINGING

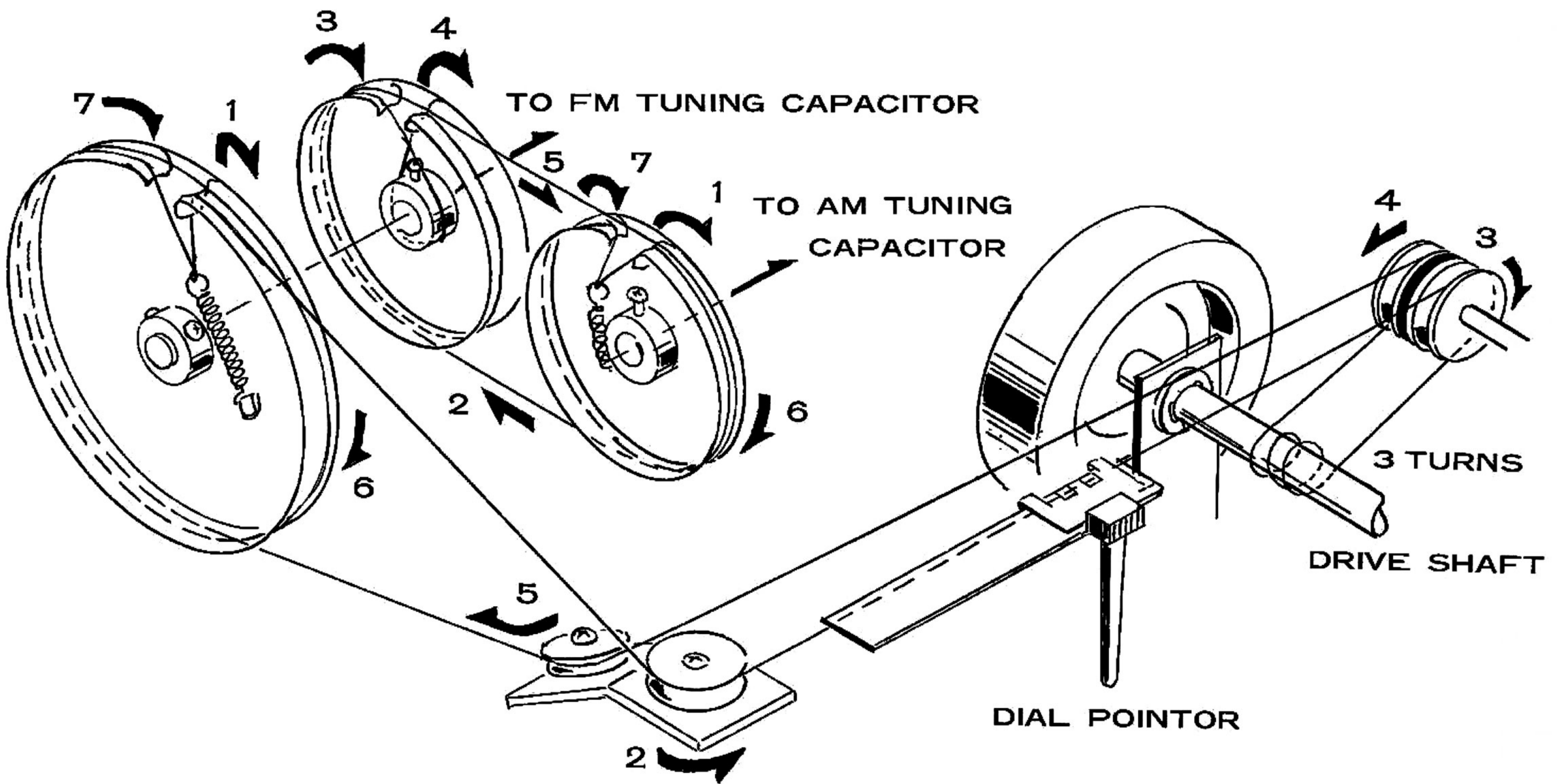

# PARTS LAYOUT

## TOP VIEW

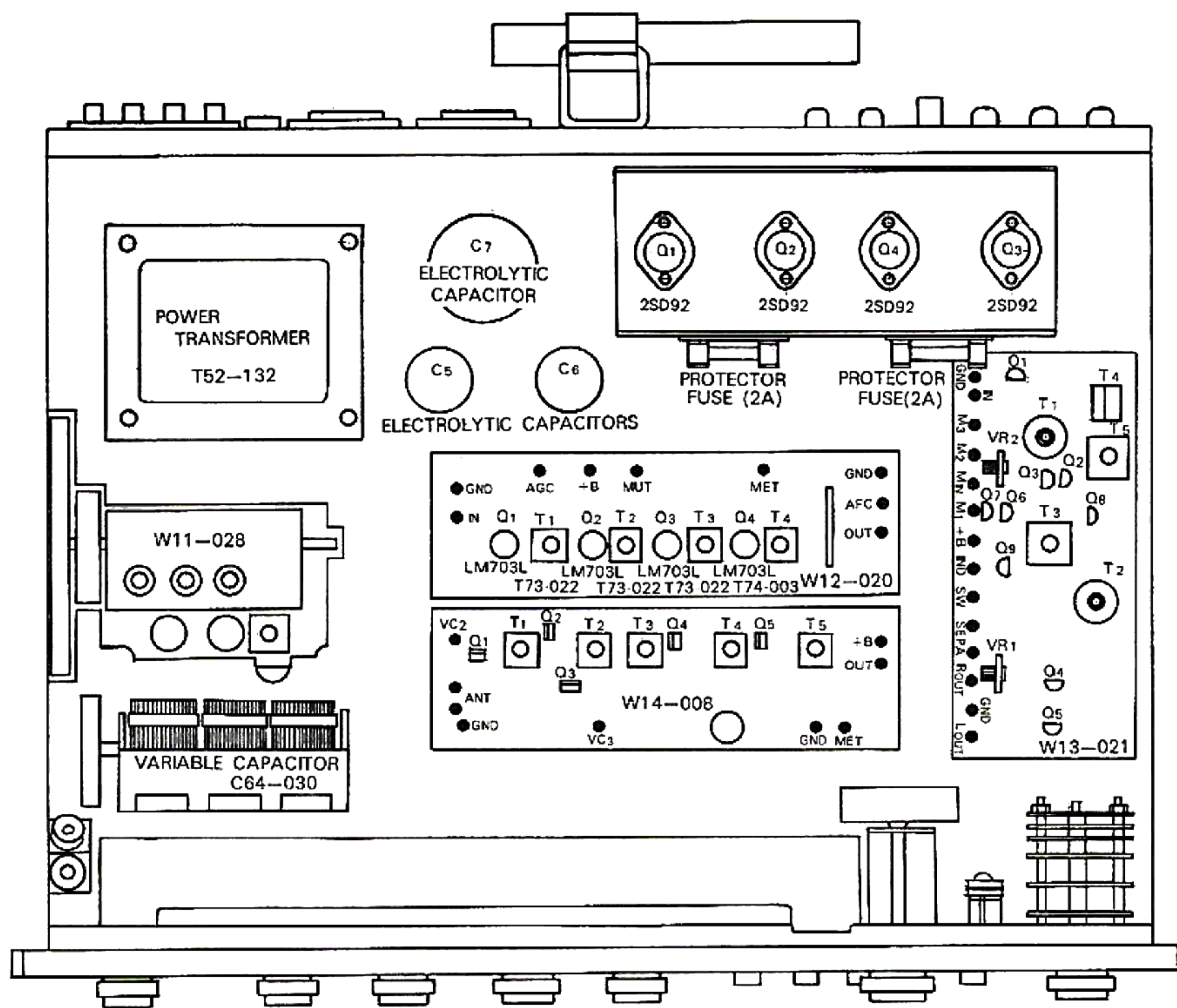

## BOTTOM VIEW

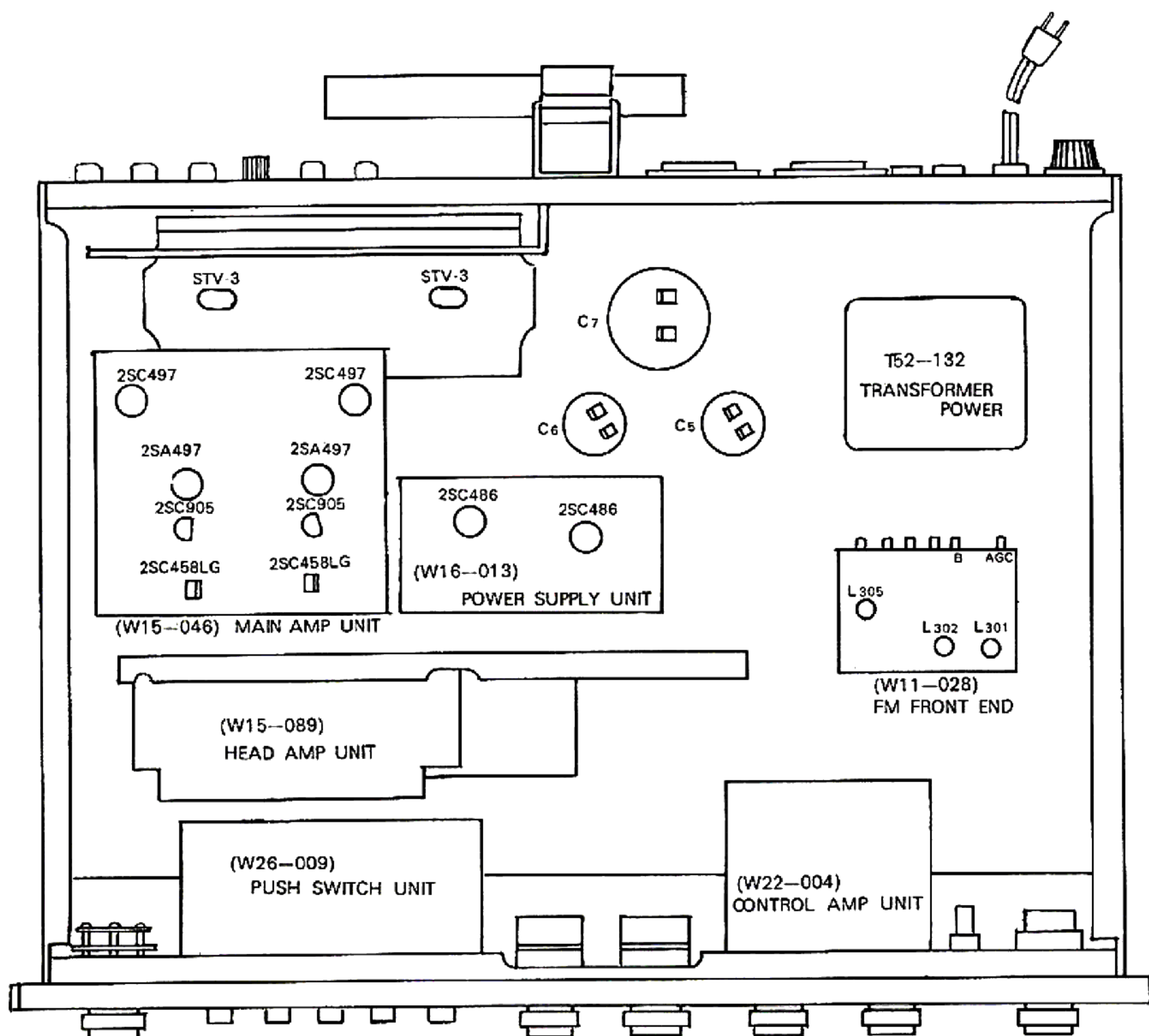

# ALIGNMENT INSTRUCTIONS

Please read these Instructions with extreme care before attempting alignment.

\* Test Equipment

1) Standard Signal Generator 2) VTVM, DC, AC 3) Oscilloscope

\* Attention on Alignment

1) Signal Generator Input: always use the minimum generator input that provides a satisfactory output indication.

2) When connecting the test equipment to the input, use a shielded wire that is as short as possible.

\* VTVM and Oscilloscope should be connected in parallel at the output.

## AM SECTION

Position of switch: SELECTOR ..... AM

Volume Control Setting: Fully Counterclockwise

STEPS	Input		Level	Dial Setting	Output Equipment Connections	Alignment	
	Equipment Connections	Frequency				Adjust	Remarks
1	Sweep Generator T.P	455kHz	70dB	Point of no interference as near as 1,605kHz	VTVM Oscilloscope OUT	T <sub>3</sub> T <sub>4</sub> T <sub>5</sub>	Adjust for maximum deflection and symmetrical characteristics
2	Signal Generator Antenna terminal through dummy	600kHz	70dB (400Hz, 30%)	600kHz	VTVM OUT	T <sub>2</sub>	Adjust for maximum deflection
3		1,400kHz		1,400kHz		CT <sub>2</sub>	
4	Repeat STEPS 2 and 3 several times						
5	Signal Generator Antenna terminal through dummy	600kHz	70dB (400Hz, 30%)	600kHz	VTVM OUT	T <sub>5</sub> Ferrite Antenna (Adjusting core)	Adjust for maximum deflection
6		1,400kHz		1,400kHz		CT <sub>1</sub> CT <sub>2</sub>	
7	Repeat STEPS 5 and 6 several times						

## FM SECTION

Disconnect IF lead of Frontend unit from the IN terminal of IF unit  
Position of Switch: Selector . . . . FM MONO

Volume Control Setting: Fully Counterclockwise

STEPS	Input		Level	Dial Setting	Output Equipment Connections	Alignment	
	Equipment Connections	Frequency				Adjust	Remarks
1	Sweep Generator IN	10.7MHz	40dB	Point of no interference as near as 87MHz	Oscilloscope MET	T <sub>1</sub> T <sub>2</sub> T <sub>3</sub>	Adjust for maximum sensitivity and symmetrical characteristics  Check symmetry of characteristic curve
2			80dB				
3	Remove electrolytic capacitor C <sub>19</sub> (5 F) from detector circuit						
4	Sweep Generator IN	10.7MHz	40dB	Point of no interference as near as 87MHz	Oscilloscope OUT	T <sub>4</sub>	Adjust the primary core of T <sub>4</sub> so that slope of straight portion of "S" curve will become the steepest and adjust the secondary core so that the center of "S" curve will coincide with the center of the marker
5	Connect IF terminal of Frontend unit to IN terminal of IF unit						
6	Sweep Generator TP of Frontend	10.7MHz	40dB	Point of no interference as near as 87MHz	Oscilloscope MET	Top of T <sub>2</sub> T <sub>1</sub> T <sub>2</sub> T <sub>3</sub>	Adjust for maximum sensitivity and symmetrical characteristics  Check symmetry of characteristic curve
7			80dB				
8			40dB			T <sub>4</sub>	
9	Connect electrolytic capacitor C <sub>19</sub> (5 F) back to where it was						
10	Signal Generator FM Antenna terminal	90MHz	20dB (400Hz, 30%)	90MHz	VTVM Oscilloscope OUT	L <sub>5</sub>	Adjust for maximum deflection
11		106MHz		106MHz		CT <sub>4</sub>	
12	Repeat STEPS 10 and 11 several times						
13	Signal Generator FM Antenna terminal	90MHz	20dB (400Hz, 30%)	90MHz	VTVM Oscilloscope	T <sub>1</sub> L <sub>1</sub> L <sub>2</sub>	Adjust for maximum deflection
14		106MHz		106MHz		CT <sub>1</sub> CT <sub>2</sub> CT <sub>3</sub>	
15	Repeat STEPS 13 and 14 several times						

## FM MPX SECTION

Position of Switch: SELECTOR..... FM AUTO  
MUTING..... OFF

Volume Control Setting: Fully Counterclockwise

Input Signal: Main (L + R) 40.5kHz Deviation (60%)  
19kHz Pilot 7.5kHz Deviation (10%)

STEPS	Circuit to be adjusted	Input		Connect VTVM	Alignment	
		Connections	Signal		Adjust	Remarks
1	19kHz Trap	Oscillator to IN	19kHz 38mV	AC VTVM ②	T <sub>5</sub>	Adjust for minimum deflection
2	19kHz and 38kHz stage	MPX Generator to FM Antenna terminal	L - R	AC VTVM OUT L or R	T <sub>2</sub>	Adjust for maximum deflection
3	Separation Control		L or R	AC VTVM OUT R or L	VR <sub>5</sub>	Adjust for minimum deflection of the other channel
4			L + R	AC VTVM OUT L and R	VR <sub>1</sub>	Adjust for less than 2dB in the difference of output
5	Repeat STEPS 3 and 4 several times					
6	Stereo Indicator light	MPX Generator to FM Antenna terminal	Pilot	AC VTVM ②	T <sub>1</sub> T <sub>3</sub>	Adjust for maximum deflection
7			Main 15dB		VR <sub>2</sub>	Adjust to light stereo indicator lamp when MPX signal is applied

## REPLACEMENT PARTS

All components used in this Allied receiver with the exception of the items listed below are standard parts. However certain parts, is listed here, were custom made to Allied specifications and should be replaced only with genuine Allied parts. These custom made parts are available only from Allied Radio. When ordering the parts, specify part number, description of part and model number of receiver.

## REPLACEMENT PARTS LIST

DESCRIPTION	ALLIED SERV. PT. NO.	MFG NO.	DESCRIPTION	ALLIED SERV. PT. NO.	MFG NO.
FM Front-end	U054-188	W11-028-D	FM IF Transformer	P054-130	T73-022-O
FM IF Unit	U054-199	W12-020-C	FM IF Transformer		
MPX Unit	U054-200	W13-021-F	(for Det.)	P054-160	T74-003-O
AM Tuner Unit	U054-190	W14-008-A	RF Choke Coil	P054-229	T24-029-A
Head Amp Unit	U054-201	W15-089-O	19kHz Transformer	P054-230	T75-020-B
Control Amp Unit	U054-181	W22-004-A	38kHz Transformer	P054-231	T75-021-B
Main Amp Unit	U054-202	W15-046-O	19kHz Transformer	P054-162	T75-021-A
Power Supply Unit	U054-203	W16-013-O	S. C. A Filter Coil	P054-158	T75-007-A
Push Switch Unit	U054-204	W26-009-O	19kHz Filter Coil	P054-157	T75-010-A
Metal Cover	S054-114	M33-127-O	Pilot Lamp for		
Front Panel	R054-132	M21-403-A	Stereo Indicator	F054-135	E22-029-O
Dial Pulley	K054-100	M42-009-B	Pilot Lamp for Dial		
Foot	F054-133	M61-017-A	Glass and Signal Meter	F054-118	E22-017-O
Dial Glass	R054-133	A33-121-O	Pilot Lamp for FM		
Dial Pointer	K054-137	A31-094-A	Stereo Indicator	F054-117	E22-002-O
Tuning Meter	M054-109	A91-009-O	SELECTOR Switch	E054-141	S13-041-O
Knob, SELECTOR	G054-127	A12-205-O	MODE/TAPE MON.		
Knob, TUNING	G054-128	A12-206-O	Switch	E054-142	S16-038-C
Knob, SPEAKERS, BASS, TREBLE, BALANCE, VOLUME and MODE/ TAPE MONITOR	G054-129	A12-207-O	SPEAKERS Switch	E054-143	S11-019-A
Knob, LOUDNESS, HIGH FILTER, LOW FILTER, TONE DEFEAT, and FM MUTING	G054-130	A19-077-O	LOUDNESS, HIGH FILTER LOW FILTER, TONE DEFEAT, and FM MUTING Switch (Push type)	E054-144	S31-032-O
Spare AC Outlet	K054-132	K82-012-O	VOLUME Control, 500k $\Omega$ dual	C054-108	C85-054-O
Speaker Socket	K054-105	K73-003-B	BALANCE Control, 250k $\Omega$ dual	C054-127	C82-048-O
Headphone Jack	K054-108	K72-006-A	SEPARATION Control, 10k $\Omega$ Semi-fixed	C054-113	C92-028-O
Pilot Lamp Socket	K054-142	K41-002-B	STV-3	A054-183	
Fuse Holder	F054-137	K91-005-A	1N60	A054-103	
Power Transformer	P054-228	T52-198-O	OA79	A054-105	
AM Ferrite			SE-05-02	A054-180	
Loopstick Antenna	L054-116	T42-024-A	FR2P	A054-266	
AM RF Coil	P054-149	T41-008-O	1S338Q	A054-182	
AM OSC Coil	P054-151	T43-007-O	2SD92	A054-145	
AM IF Transformer	P054-152	T71-025-O	LM703L	A054-238	
AM IF Transformer (for Det.)	P054-153	T72-017-O	2SC458LG-C	A054-194	

DESCRIPTION	ALLIED SERV. PT. NO.	MFG NO.
2SC486-BL	A054-267	
2SC458LG-B	A054-265	
2SC461-A	A054-163	
2SC460-A	A054-148	
2SC871 BL or GR	A054-253	
2SC870 BL or GR	A054-194	
2SC905	A054-185	
2SC497	A054-186	
2SA497	A054-187	

## ALLIED WARRANTY

Your Allied Receiver is warranted to be free from defects and workmanship under normal use for a period of one (1) year.

1. During the first ninety (90) days from date of sale we will at our option, either repair, or replace and install, any defective parts free of charge.
2. After ninety (90) days and for the balance of the year we will replace all defective parts, charging only for labor.

## IMPORTANT INSTRUCTIONS

Should such a defect occur, contact our Customer Service Department informing us of the nature of the problem. Prior authorization and directions must be obtained before returning the product for service. Upon your receipt of a return authorization, you may return the product shipping the unit prepaid dully insured and carefully packed to avoid possible damage in shipment.

If service is required for defects or labor not covered by this Warranty, an estimate will be forwarded to you before repairs are made.

PRINTED IN JAPAN  
< R12-083-0 >